

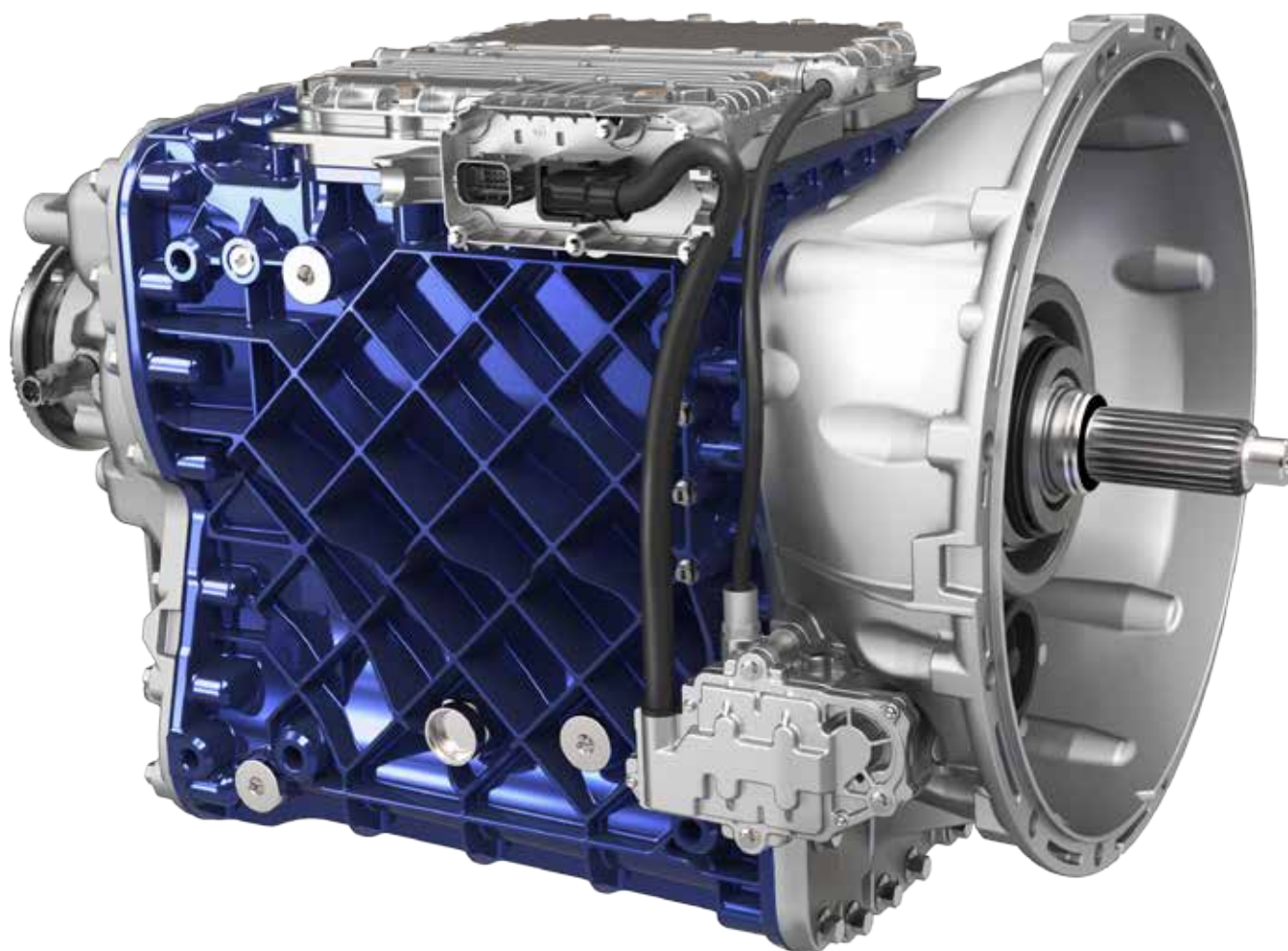

Volvo Trucks. Driving Progress

# VOLVO I-SHIFT

PRODUCT GUIDE



# An automated manual transmission with digital intelligence.

Volvo has made the industry's most advanced automated manual transmission even better. The latest edition of the Volvo I-Shift transmission includes upgraded hardware and software, greater durability, and a new countershaft brake for improved performance and smoother, faster shifting. The electronic control unit can handle any load and any road, shifting perfectly every time. We've also improved clutch durability and torsional dampening in both our D11 and D13 models. So I-Shift not only keeps fuel costs down, it can also help slow driveline wear, reduce noise and vibration, extend transmission life, and lower maintenance costs.

Whether your route includes rolling hills or steep mountain terrain, Volvo's I-See predictive cruise employs self-learning knowledge of road topography to work with I-Shift, helping your drivers optimize the truck's speed and gear shifting.



## Makes every driver more fuel-efficient.

Our newest I-Shift makes drivers more productive, using intelligent electronics to continuously monitor grade, speed, weight, and engine load, shifting when necessary or holding a gear—whichever saves more fuel. So regardless of experience or training, I-Shift helps every driver become more fuel-efficient.



## Eases your mind and your left foot.

Once you drive an I-Shift, you'll never want to deal with a clutch pedal again. I-Shift lets you concentrate on the task at hand—delivering freight—not on what gear you're in. It's easy to use and always ready with the right gear, so missed shifts and sore knees are a thing of the past. With I-Shift, just sit back, get comfortable, and concentrate on your driving.



## Brains, brawn, and value.

With a D11 or D13 engine, Volvo's torque rating for I-Shift goes up to 1,900 lb-ft., so it's compatible with any Volvo engine you choose. I-Shift can also increase your truck's resale value. If your Volvo truck was purchased with a lower engine power rating, a simple software flash can uprate it to the highest power rating for its displacement—without having to replace the transmission.



## Design changes save fuel and time.

I-Shift's redesigned transmission cooler optimizes fluid temperature in cold and warm climates, improving fuel efficiency. Connections throughout the transmission are also upgraded for faster maintenance during service stops.

# Now every road is worth remembering.

Combine I-Shift with an intelligent cruise control and you get I-See. It's a unique system that learns the topography of the road. Later on, it automatically uses its knowledge to save fuel when the intelligent cruise control is engaged.

## Uphill.

When I-See knows an uphill grade is coming, it increases speed in preparation. Once the climb begins, I-See uses its stored knowledge to avoid unnecessary downshifts towards the top. You approach the crest smoothly without wasting fuel in a lower gear at the top of the climb.

## Downhill.

Just before the slope, I-See engages Eco-Roll® which disengages the driveline and lets the truck roll for the optimum period before re-engaging the driveline. This saves energy and minimizes the need for braking. I-See also knows when the slope ends. So it can apply the engine brake gently in time, rather than abruptly at the end, or continue to gain momentum for an upcoming hill.

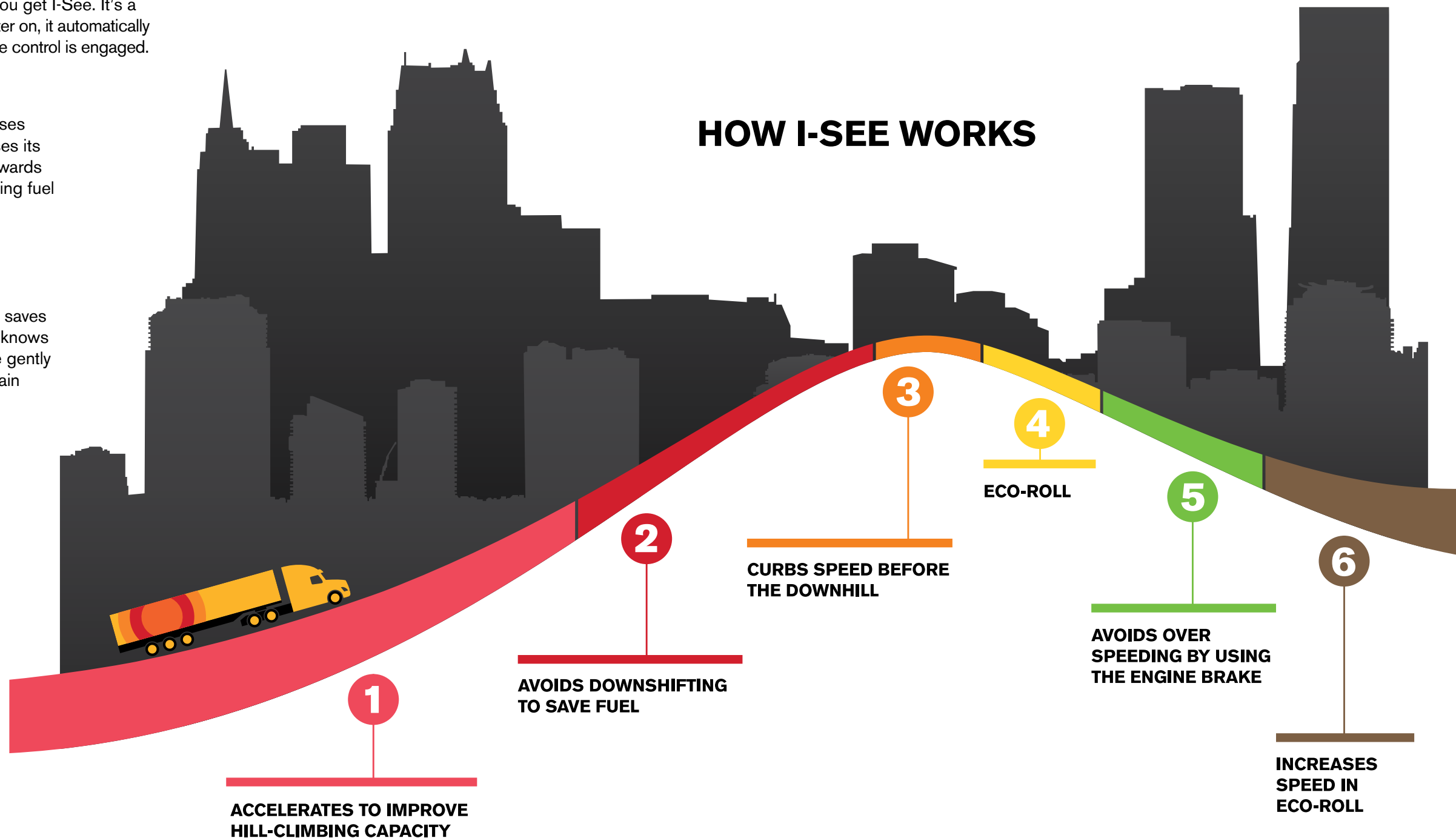



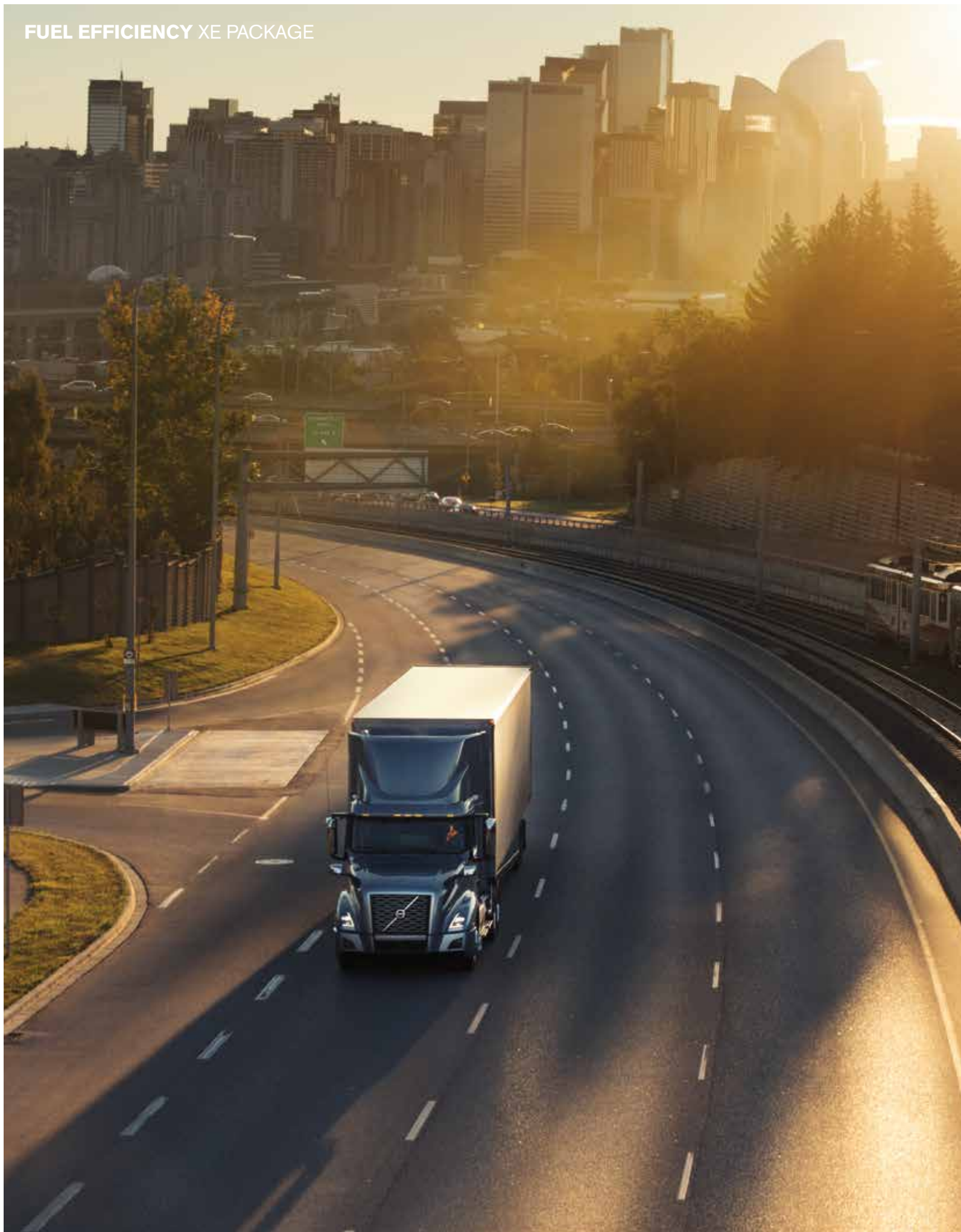

# Extreme fuel efficiency. Great drivability.

The award-winning eXceptional Efficiency (XE) packages push Volvo's commitment to fuel efficiency and reliability even further.

XE isn't a single fuel-saving feature; it's a completely customized solution that perfectly matches your vehicle and powertrain settings to the needs of your business. It all starts with choosing the right Volvo engine and matching it with an I-Shift transmission. Then, we help you choose the optimum efficiency package based on your application. Together, these factors can help you save up to an additional 0.2 mpg or more. That can mean savings of as much as \$2,000 per year, per truck.

You tell us what you haul and where you haul it, and we'll tell you how XE can help your trucks get the job done while helping your business save big on fuel.

Our XE packages get smarter every year. A customized XE package is now available for liquid tanker, flatbed, and bulk haul applications.

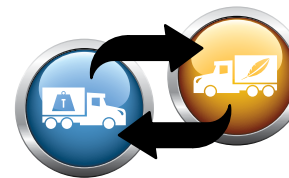

### **XE Adaptive Gearing.**

The first drivetrain in the industry to use rear suspension load to change the driveline based on whether the vehicle is loaded or unloaded. It gives you two transmissions in one: the performance of a direct drive when loaded and a downspeeding overdrive when light.



### **A wider sweet spot.**

In some applications, XE packages help you save fuel by widening the sweet spot rpm range of the engine. Traditional drivelines achieve peak fuel efficiency between 1300-1500 rpm. But through Volvo's use of downspeeding, XE widens the range to 1050-1500 rpm. For every 100 rpm of downspeeding, fuel efficiency is improved by approximately 1.5%. Since the Volvo XE13 package downspeeds the engine by 200 rpm or more, you'll realize a total fuel efficiency increase of up to 3%.

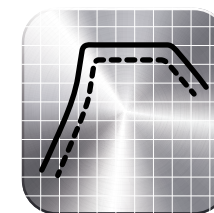

### **Choose your torque.**

The latest XE13 package is now available with your choice of different engine torque management software. XE Economy lowers engine torque in the starting gears, maximizing tire and driveline reliability while providing ample power and torque to get the job done at cruise speed. XE High Torque allows maximum torque in all gears, for those who prefer a faster transition to cruise speed.



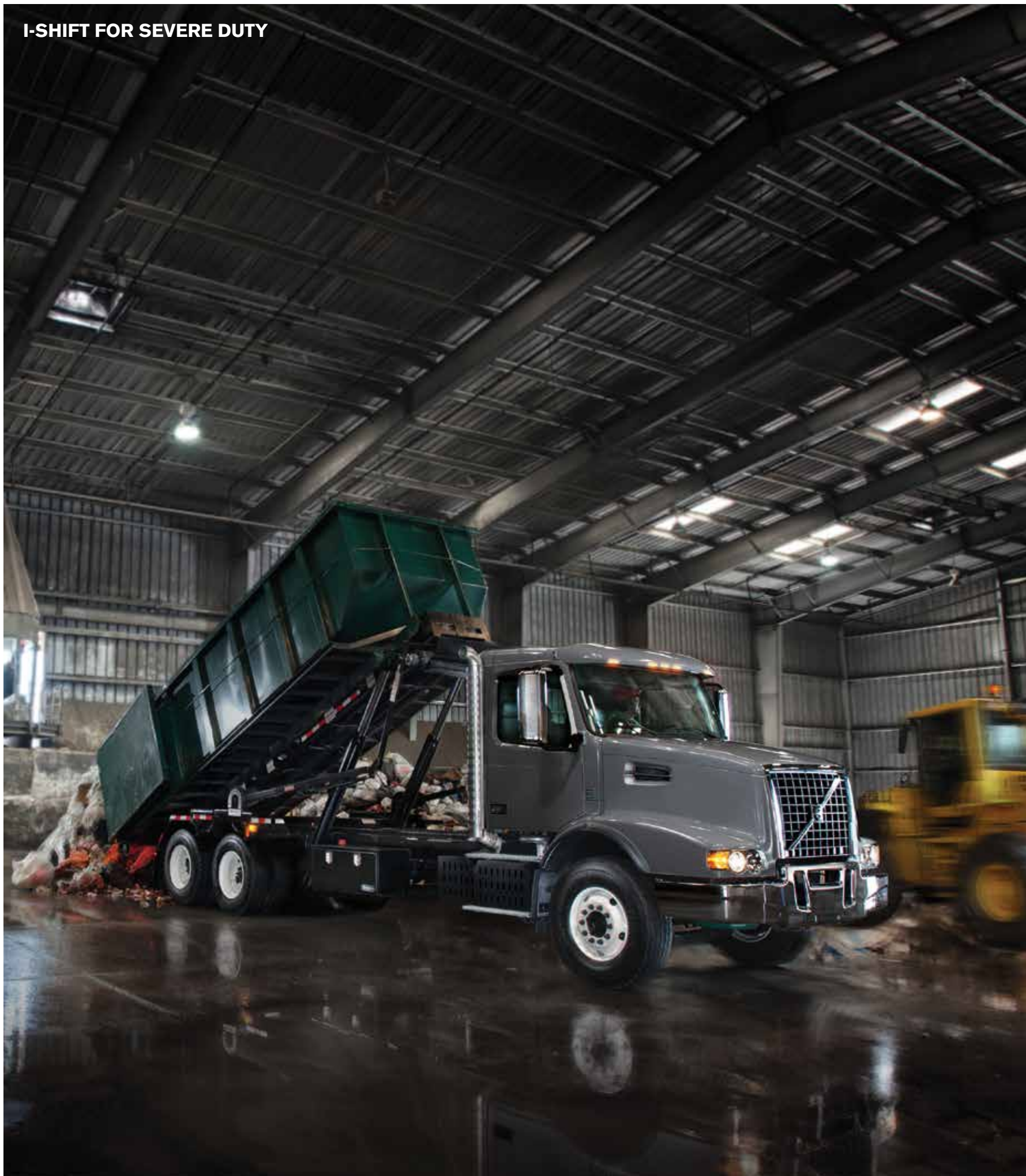

## Built for the toughest jobs.

The improved I-Shift for Severe Duty transmission is built for rugged applications. It can be found standard on all VHD models and is optional for all other models. The latest edition of the I-Shift for Severe Duty includes upgraded hardware and software, improved engaging sleeves and a new countershaft brake for improved performance and smoother shifting.



### **Power take-off.**

It has never been easier to perform multiple tasks with your truck, thanks to Volvo's power take-off (PTO). With nine PTO offerings, Volvo offers the right combination for your application, no matter what body you operate or powered equipment you have to drive. With the ability to provide PTO drive connections in three different positions (Front Engine PTO, Rear Engine PTO and Transmission Mounted PTO) for gear pumps, piston pumps or direct drive shaft connections, you'll find the right match for your job.



### **Performance software package.**

The I-Shift with the Performance software package offer the P+ Enhanced Performance mode, adapted for construction and heavy haul applications. This mode includes various functions that adapt shift points and gear selection to poor driving surfaces and hilly road stretches. It includes functions that aid starting from a standstill in less than ideal driving conditions. The performance software package also gives the driver the ability to rock free if needed.



### **Power launch.**

The Power Launch feature is a part of the performance software package. It is activated to provide extra torque when starting from a standstill, when loaded to capacity, or on poor terrain. The feature matches torque to the terrain, minimizing wheel-slip on soft surfaces.



# Make the shift to ultra low-speed control.

When steep-grade startability, low-speed maneuverability, or maximum GCW loads are critical, the I-Shift with Crawler Gears is the answer. The crawler option adds either one or two gears to the I-Shift for Severe Duty, a low gear and an ultra-low gear, making it a 13- or 14-speed transmission.



## Ready. Set. Slow.

The new I-Shift with Crawler Gears is now available for vocational applications. It enables controlled forward and reverse travel at extremely slow speeds, down to 0.6 mph with a 3.58 rear axle ratio. It is perfect for paving and curbing applications. The new I-Shift brings fuel efficiencies at highway speeds because you are able to run at lower RPMs.



## Extreme loads are no problem.

The I-Shift with Crawler Gears can haul up to 220,000 lbs.\*, among the industry's highest weight ratings. The crawler gears deliver outstanding steep-grade startability. And it still comes standard with the smooth shifting and fuel efficiency drivers expect from the I-Shift.

\*Requires component compatibility approval.

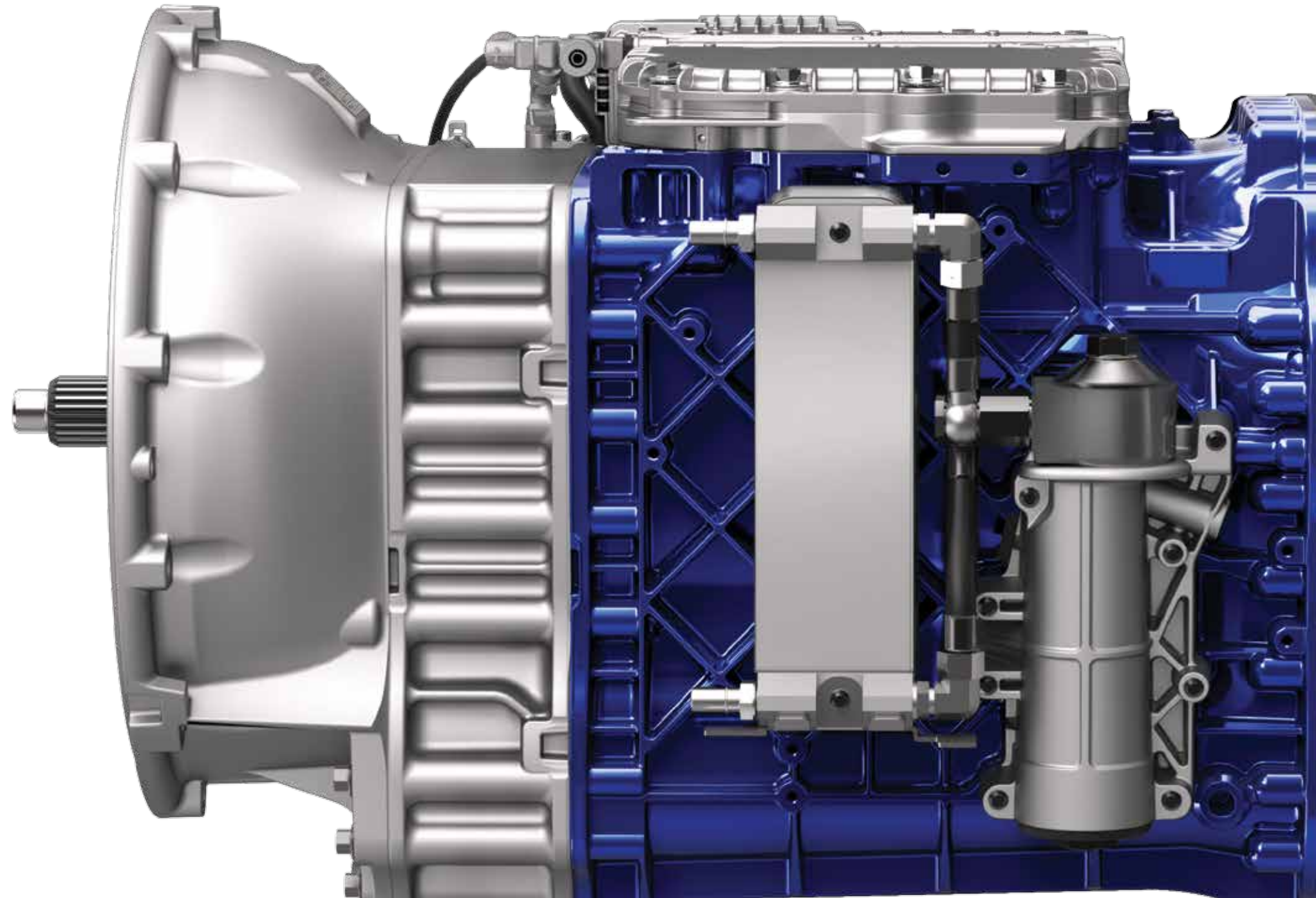



## Industry leading. Just in case.

To make sure that our trucks are the safest on the road, we combine advanced engineering with active and passive safety systems. I-Shift serves an important role in keeping drivers safe and alert.



### **Fewer distractions.**

I-Shift takes away the physical and mental demands of changing gears, which reduces driver fatigue and provides more time for the driver to give full attention to surrounding traffic.



### **At your fingertips.**

Reaching is eliminated by a control stalk on the side of the steering column. The cruise control and all engine brake controls, along with transmission information, are all within easy access for the driver.

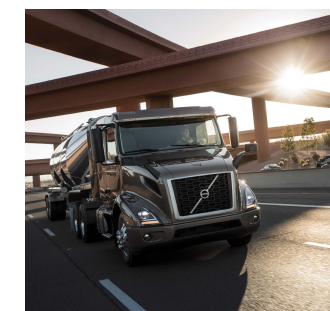

### **Volvo Engine Brake.**

The I-Shift is perfectly integrated with our Intelligent Volvo Engine Brake (I-VEB). I-VEB allows for multiple levels of engine brake blending with the pedal. It can also assume 100% control to maximize retardation and overall engine brake performance. During coasting, the brake cruise and engine brake can be activated.



# No matter where, we're there to support your business.

I-Shift improves uptime by reducing wear-and-tear on the powertrain. But when you do need regular maintenance, our world-class dealer network means your trucks are never far from the quality care you expect. With more than 360 dealers and thousands of service locations across North America, Volvo's Uptime Services help you through every step of a service event, and make sure your trucks stay where they belong—on the road.



### Service intervals.

I-Shift requires minimal service and maintenance. Oil drain intervals for on-highways applications can extend up to 500,000 miles. The integrated lube filter provides protection against foreign particles in the transmission, and the actuator is completely sealed to be maintenance free.



### Warranty.

The I-Shift transmission is backed by one of the industry's leading warranties: up to 5 years/750,000 miles/15,000 hours on the transmission, and 3 years/300,000 miles on the clutch for over the road applications.



### Upgradeability.

The Volvo I-Shift allows for unlimited torque and engine power settings and can be upgraded at any time with a software update, providing greater flexibility for your applications and greater value at resale.





**VOLVO**

**Volvo Trucks**

[www.volvotrucks.us](http://www.volvotrucks.us) | [www.volvotrucks.ca](http://www.volvotrucks.ca)

Volvo Trucks Canada  
2100 Derry Road West, Suite 410  
Mississauga, Ontario L5N 0B3

Volvo Trucks North America  
7900 National Service Road  
Greensboro, NC 27409

Volvo Trucks Mexico  
Torre Zentrum piso 21  
Av. Santa Fe #495 Col. Cruz Manca  
Del. Cuajimalpa Ciudad de Mexico.  
CP05340

Some vehicles shown with optional equipment.

©2017 Volvo Truck Group North America, LLC