



## Power Take-off (PTO)

This information provides specification for Power Take-off (PTO) applications in Volvo vehicles.

**Note:** We have attempted to cover as much information as possible. However, this information does not cover all the unique variations that a vehicle chassis may present. Note that illustrations are typical but may not reflect all the variations of assembly.

All data provided is based on information that was current at time of release. However, **this information is subject to change without notice.**

Please note that no part of this information may be reproduced, stored, or transmitted by any means without the express written permission of Volvo Trucks North America.

### Contents:

- “General”, page 3
- “Abbreviations”, page 3
- “PTO Speed Functions”, page 4
- “PTO Functions”, page 5
- “Power Take-off Types”, page 7
- “Transmission-mounted PTO”, page 9
- “Transmission-driven PTO”, page 22
- “Power Take-off (PTO), Installation (I-Shift)”, page 23
- “Diesel Exhaust Fluid (DEF) Cooling Lines, Side Mounted PTO”, page 34
- “Engine Mounted Power Take-off”, page 35
  - “REPTO”, page 42
  - “Front-mounted Engine PTO”, page 46

- “Hydraulic Pumps”, page 53
- “Volvo Body Builder Prep”, page 94
- “PTO Programming”, page 97
- “PTO Setup in VECU (both “stalk” PTO and wired/remote PTO1)”, page 102
- “Regeneration in PTO Mode”, page 114
- “Paver Assist for I-Shift: New Generation AMT-F ”, page 117
- “Auto Neutral for I-Shift AMT-F”, page 118
- “Supplier PTO/Pump Literature”, page 118

# Overview

## General

Auxiliary equipment require power take-offs, either when the truck is stationary or when it is in motion. Various power take-off alternatives can be chosen, depending on the bodywork.

The work is generally carried out by equipment which is powered by a hydraulic motor. The hydraulic motor, together with a pump and associated equipment, form the basis of the hydraulic system. The pump, which provides the hydraulic pressure and flow to the motor, is the heart of the hydraulic system.

All power take-offs covered by this chapter are available factory installed. Some variants can also be ordered. It is important to design an optimum hydraulic system, and to specify the correct pump size to provide sufficient oil flow and prevent overloading of the power take-off.

## Power Take-off

There are a number of different power take-off variants available, with single or double outlets. The power take-off is supplied with one of several output drives, keyed shaft, SAE drive flange or internal splined DIN.

Power take-offs are classified into two family variants: **Clutch dependent** and **Clutch independent**

**Note:** See Tool Tab in the Body Builder Portal for the Pump Speed Calculator.

## Abbreviations

PTR	=	Single power take-off transmission, rear mounted ( <b>P</b> ower take-off <b>T</b> ransmission <b>R</b> ear). All are rear-facing.
PTRD	=	Double power take-off transmission, rear mounted ( <b>P</b> ower take-off <b>T</b> ransmission <b>R</b> ear mounted, <b>D</b> ouble)..
REPTO	=	Engine mounted power take-off located at the rear end of the engine ( <b>P</b> ower <b>T</b> ake-off <b>E</b> ngine <b>R</b> ear).
EPTT	=	Maximum permitted torque on engine power take-off ( <b>E</b> ngine <b>P</b> ower <b>T</b> ake-off <b>T</b> orque).
HPE	=	Hydraulic pump mounted to an engine power take-off ( <b>H</b> ydraulic <b>P</b> ump <b>E</b> ngine mounted).

# PTO Speed Functions

For the purposes of this manual, PTO (Power Take–Off) is a function to maintain engine speed regardless of engine load. Think of it as cruise control for the engine - only instead of maintaining a steady vehicle speed, it is maintaining engine speed. It is most often used to provide increased steady engine speed when operating auxiliary equipment such as hydraulic pumps or compressors. The term "PTO" has come to mean both the function of maintaining constant engine speed during use of auxiliary equipment, as well as a term for the auxiliary equipment itself.

There are two types of PTO engine speed control used in Volvo trucks:

## Electronic Hand Throttle

### (EHT/PTO 0)

This type of PTO is standard equipment; it is initiated and controlled using the cruise control "ON/OFF", "SET+", "SET-", and "RESUME" stalk switches. Manufacturers refer to this function by different names - Mack calls it "Electronic Hand Throttle" (EHT), some European manufacturers (including Volvo Trucks in Sweden) call it a "high idle" function. In this manual we will refer to it as "Stalk PTO", even though some of the parameters for programming this function will refer to it as "high idle". (Note that in the North American market, the term "high idle" usually refers to the maximum possible engine speed under no-load conditions).

### "Physical" or "Wired" PTO

This type of PTO is most commonly associated with the engagement of engine- or transmission- "Wired" PTO driven accessories, where the user wishes to "remotely" activate the engine speed control function. It is usually accomplished by wiring the auxiliary equipment to the PTO function controller (VECU, BBM ECU, or Engine ECU) so that engaging one will automatically activate the other.

How each of these different PTO functions operates will depend upon the installed engine. For Volvo engines, the PTO functions are split between the Engine ECU, VECU, and, if equipped, the BBM ECU. Cummins engines, on the other hand, contain all of the PTO functionality within the Engine ECU itself.

- Electrical, PTO Programming
- Electrical, Electronic Control Unit (ECU)
- Electrical, Body Builder Packages and Functions

## Notes

---

---

---

---

---

---

# PTO Functions

## PTO Functions with the Volvo D11F and D13F

A "PTO" icon will appear in the instrument cluster only when 'Remote' ('Wired') PTO is engaged. No icon will appear while in Stalk PTO.

## Electronic Hand Throttle PTO

The VECU reads the cruise control stalk switch states, and commands the engine into PTO mode when conditions are right. These conditions are programmable in the VECU and might include a maximum vehicle speed, park brake set or not, etc.

The engine PTO 'set speed' is selected by either pressing the cruise control "RESUME" button, or by using the accelerator pedal to get the desired engine speed and pressing one of the cruise control "SET" buttons (either SET+ or SET-). Once the PTO function is active, the SET or SET- buttons can be used to adjust the PTO engine speed (within limits).

## Physical or Remote/Wired PTO

This type of PTO speed control works similarly to 'Stalk PTO', except that the function is activated by applying an external signal to a dedicated PTO input pin on the VECU. The set speed can be adjusted using the cruise control SET + or SET- buttons, as above.

If the vehicle is equipped with a Body Builder Module (BBM) ECU, then three (3) additional PTO functions are available. With the 1 PTO function of the VECU, a total of four (4) PTO 'modes' exist. (Each 'mode' offers the ability to independently select a different set speed and control independent outputs (explained below)).

A sub-function of the 'wired' PTOs in the VECU and BBM ECU is the ability to activate PTO "outputs". Traditionally, the auxiliary device (PTO pump, bypass solenoid, etc.) is wired to be activated by the same switch which initiates the engine speed control function. This means that the hardware will be engaged whenever the switch is on, even if the engine speed is not being controlled (it would not even know whether the engine is running or not). Also, there is no protection against an input switch that has been accidentally activated.

Using the PTO "Output Control" function of the VECU and BBM ECU, it is possible to prevent engagement of the auxiliary equipment until certain conditions are met - park brake set, engine speed within a certain range, etc. This is accomplished by controlling the auxiliary equipment with the VECU or BBM ECU, instead of directly from a switch. Although the ECUs still read the switch input, the ECUs will only allow the auxiliary device to engage when conditions are right.

# PTO Functions with the Cummins Engines

With Cummins engines, all PTO functionality is fully contained in the Engine ECU. A "PTO" icon will appear in the instrument cluster when either Stalk or 'Remote' ('Wired') PTO is engaged.

## **Electronic Hand Throttle PTO**

This type of PTO is standard equipment; it is initiated and controlled using the cruise control "ON/OFF", "SET+", "SET-", and "RESUME" stalk switches. Manufacturers refer to this function by different names - Mack calls it "Electronic Hand Throttle" (EHT), some European manufacturers (including Volvo Trucks in Sweden) call it a "high idle" function. In this manual we will refer to it as "Stalk PTO", even though some of the parameters for programming this function will refer to it as "high idle". (Note that in the North American market, the term "high idle" usually refers to the maximum possible engine speed under no-load conditions). The VECU reads the state of the various switches (cruise control stalk switches, brake and clutch pedal position, etc.) and passes that information to the Engine ECU over the J1939 datalink. The VECU does not 'interpret' or condition the information before sending it, and so plays no part except to supply the "inputs". The Cummins engines offer three (3) stalk PTO set speeds, which are programmed in the Engine ECU. They are referred to as the "Set" speed, the "Resume" speed, and the "Set+Resume" speed. Pressing the corresponding cruise control stalk switch(es) selects each of the three set speeds. Once engaged, the cruise control SET+ and SET- switches can be used to adjust the set speed. Note that the SET + / SET- buttons must be HELD in order to adjust the speed, not 'tapped'.. 'tapping' them will yield the "Set" pre-set speed!

## **"Physical" or "Wired" PTO**

This type of PTO is most commonly associated with the engagement of engine- or transmission- "Wired" PTO driven accessories, where the user wishes to "remotely" activate the engine speed control function. It is usually accomplished by wiring the auxiliary equipment to the PTO function controller (VECU, BBM ECU, or Engine ECU) so that engaging one will automatically activate the other. When using this style of PTO with the Cummins engine, the VECU is not used at all. The circuit used to activate the Remote PTO is wired directly to the Cummins Engine ECU. That circuit (there is only one) can select up to five (5) PTO modes, depending on the number of times it is turned ON and OFF in rapid sequence. See Cummins documentation for details. There is no BBM ECU available for interfacing to the Cummins engines; also there are no "PTO Output" functions available with the Cummins engines.

## *Notes*

---

---

---

---

---

---

# Power Take-off Types

## Clutch Dependent Power Take-off

Clutch dependent power take-offs are designed to work when the truck is parked. Common applications are dump trucks, mobile cranes, tank trucks, etc. They are mounted on the transmission and stop working when the clutch pedal is depressed.

**Note:** The clutch pedal must be depressed (if equipped), to engage or disengage the power take-off.

- PTR-XX
- PTRD-XX

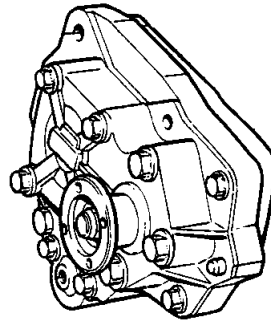

T4006562

PTR-FL

## Clutch Independent Power Take-off

A clutch independent power take-off is mainly used when work is to be done when driving. Applications could include refrigerated, hook lifts, concrete mixer, snow plows/sand spreaders, etc. They are designed to be installed either on the front of the engine or rear of the timing cover.

## Rear Engine Power Take-off REPTO

An engine mounted power take-off is mounted on the rear of the timing cover.

### *D11 and D13*

On the D11 and D13 engines the power take-off is ordered separately, either as:

- **PTR-DIN** (DIN5462/ISO7653 connection)
- **PTR1300** (flange SAE1300) (not D13)
- **PTR1400** (flange SAE1400)

The hydraulic pump (variants HPE-XXX) can be ordered separately on these engines together with PTO variant PTR-DIN:

- **PTR-DIN + HPE-XXX**  
(Engine power take-off together with engine mounted hydraulic pump)

**Note:** Former variant names are changed. PTR-FXX/-VXX are replaced by PTR-DIN + HPE-FXX/-VXX.

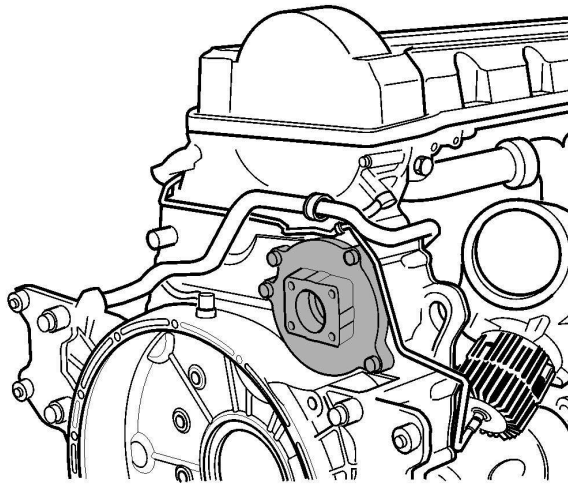

T9008395

REPTO-DIN

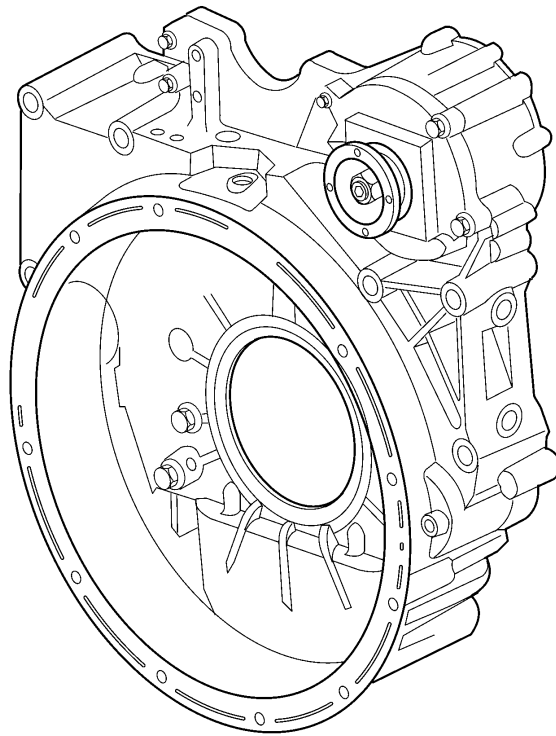

W4002977

Rear-mounted Engine PTO with Flange SAE 1410/ ISO 7647

# I-Shift Power Take-off

The I-Shift is an automated manual transmission. When the PTO is engaged and if the Drive mode “D” is selected, the TECU commands the clutch to release and engage the countershaft brake. This stops the rotation of the countershaft and the PTO. When the driver releases the brake pedal and applies the throttle, the clutch re-engages and the PTO starts to rotate along with the countershaft.

When the driver stops the truck and if the reverse mode “R” is selected, the clutch disengages and reverse gear engages. When the reverse gear engages, the transmission-mounted PTO disengages. When the driver releases the service brake and applies the throttle, the clutch re-engages and the PTO engages and starts to rotate again.

If the driver wants to use the transmission-mounted PTO while moving the vehicle, the transmission will only be able to operate in the starting gear that was selected. Depending on the vehicle options and starting gear selected, the maximum vehicle speed is usually around 6 mph.

The I-Shift with transmission-mounted PTO may not be the solution for the Roll Off Chassis. The REPTO (MP engines only) unit is best suited for Roll Off Chassis application, where the truck requires to use the PTO while driving. The PTO with the Allison Transmission is also suitable for Roll Off Chassis applications.

## Transmission-mounted PTO

### VOLVO I-Shift, AMT

This information is meant as an aid to identify transmission PTO options available with the I-Shift transmission.

The following table shows the available PTO's with installation kit part numbers.

PTO Type	PTR-D	PTR-F	PTR-FL	PTR-DM	PTRD-F	PTRD-D	PTRD-D1	PTRD-D2	PTRD-D3	PTRD-D4
Part Number	210271-01	210271-19	207704-42	227704-48	213093-08	213094-72	213094-77	213094-95	232837-84	232837-85
Installation Kit Number	851356-39	851356-39	851356-39	851356-39	851356-39	851356-39	851356-39 and 212290-46	851356-39 and 212290-46	851356-39 and 212290-46	851356-39 and 212290-46
Software Accessory Kit AMT-F	851373-35	851373-35	851373-35	851373-35	851373-35	851373-35	851518-40	851518-40	851518-40	851518-40

**Note:** 23664407 adapter kit is needed for the 21027101 PTR-D PTO.

Installation Kit 85135639 includes parts required for installing types PTR-D, PTR-F, PTR-FL, PTR-DM, PTR-DH, PTRD-F, PTRD-D. For installing PTRD-D1, PTRD-D2, PTRD-D3, PTRD-D4, it is required to have the installation kit 21229046 along with the 85135639.

To have pneumatic connections for PTO control, PTRD-D2, PTRD-D3 and PTRD-D4 require a separate valve kit, 23720743.

*I-Shift Transmission Mounted PTOs*

PTO	Connection		Direction of Rotation	Max. Horsepower (kW)	Max. Torque ft-lb (Nm)
Type	Type	Dimension			
<i>Single</i>					
PTR-FL	Flange	SAE1300	Counter clockwise when facing back of engine	134 (100)	443 (600)
PTR-DM	Direct	DIN5462			
PTR-D	Direct	DIN5462	Clockwise (viewed from rear)	200 (150)	740 (1003)
PTR-F	Flange	SAE1410	Clockwise (viewed from rear)	200 (150)	740 (1003)

PTO	Connection		Direction of Rotation	Max. Horsepower (kW)	Max. Torque ft-lb (Nm)		
Type	Type	Dimension					
<b>Double and Triple</b>							
PTRD-F	Flange (Outer)	SAE1400	Clockwise when facing back of engine	188 (140)	642 (870)		
	Direct (Inner)	DIN5462	Counter clockwise when facing back of engine				
PTRD-D	Direct (Front)	DIN5462	Counter clockwise when facing front of engine				
	Direct (Rear)		Clockwise when facing back of engine				
PTRD-D1	Direct (Front)	DIN5462	Counter clockwise when facing front of engine				
	Flange (Rear)	SAE1400	Clockwise when facing back of engine				
PTRD-D2	Direct (Front)	DIN5462	Counter clockwise when facing front of engine			Max power inner and outer shafts must not exceed 188 hp (140)	Max Torque 642 ft-lb (850). See table below.
	Flange (Outer)	SAE1300	Clockwise when facing back of engine				
	Flange (Inner)	SAE1400	Counter clockwise when facing back of engine				
PTRD-D3	Left-hand side: Direct	DIN5462 / ISO 7643	Counter clockwise when facing back of engine			95 kW (127.4 hp)	See "Dual PTO Specifications", page 16
	Right-hand side: Direct			125 kW (167.6 hp)			
PTRD-D4	Left-hand side: Direct	DIN5462 / ISO 7643	Counter clockwise when facing back of engine	95 kW (127.4 hp)	See "Dual PTO Specifications", page 16		
	Right-hand side: Flange	SAE 1310/1410		125 kW (167.6 hp)			

## Power Take-Off (PTRD-D2) Maximum Torque

642 ft-lb (850) Maximum PTO Torque for PTRD-D2	
Inner shaft ft-lb (Nm)	Outer shaft ft-lb (Nm) [sum of front and rear PTO]
738 (1000)	148 (200)
664 (900)	221 (300)
516 (700)	295 (400)
369 (500)	369 (500)
203 (275)	443 (600)
48 (65)	516 (700)

## Engine PTO in combination with AMT

For the vehicle with the *I-Shift* transmission, the **engine** power take-off can be engaged during driving (depending on parameter setting) but the maximum torque must not exceed the predefined limit. Exceeding the maximum torque (shown in the table below) can cause problems during gear shifting. For this reason, it is recommended that equipment shall be designed so that the torque limits in the table below are not exceeded during driving.

Engine	Maximum Torque Horsepower (Nm) While Driving
D11	148 (200)
D13	221 (300)

### Notes

---



---



---



---



---



---

# Speed Ratio for I-Shift Transmission Mounted PTOs (Engine: PTO)

Engine Speed: Transmission PTO Ratio (Example – 1:1.65)

Power Take-off Type	Weight (lbs)	Overdrive		Direct	
		Low/Neutral-1	High/Neutral-2	Low/Neutral-1	High/Neutral-2
<b>Single</b>					
PTR-FL	35.3	0.93	1.18	0.73	0.93
PTR-DM	28.7	1.35	1.72	1.06	1.35
PTR-D	7.7	0.9	1.15	0.7	0.9
PTR-F	13.2	0.9	1.15	0.7	0.9
<b>Double and Triple</b>					
PTRD-F (Outer)	41.9	1.65	2.10	1.30	1.65
PTRD-F (Inner)		0.77	0.98	0.60	0.77
PTRD-D	44.1	1.65	2.10	1.30	1.65
PTRD-D1	57.3	1.65	2.10	1.30	1.65
PTRD-D2 (Outer)	70.5	1.65	2.10	1.30	1.65
PTRD-D2 (Inner)		0.77	0.98	0.60	0.77
PTRD-D3 (LHS)	58.6	0.76	0.97	0.60	0.76
PTRD-D3 (RHS)		1.29	1.64	1.01	1.29
PTRD-D4 (LHS)	70.3	0.76	0.97	0.60	0.76
PTRD-D4 (RHS)		1.29	1.64	1.01	1.29

**Note:** When the truck is stationary, use of crawler gears is not allowed to run the PTO.

**Note:** If the PTO operating condition exceeds 100 hp (75 kW) for 15 minutes, the PTO requires the oil cooler.

## Notes

---



---



---



---



---

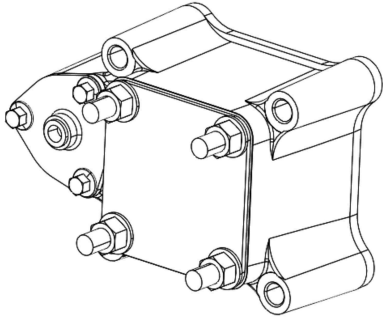

T4173618

**PTR-D**

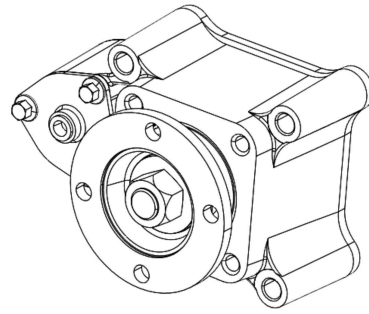

T4173619

**PTR-F**

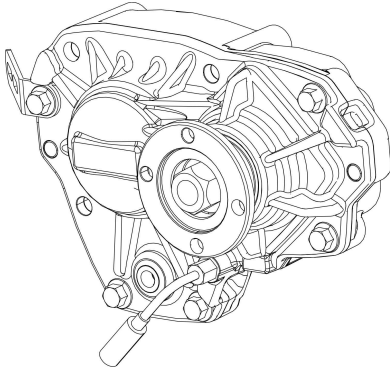

W2122051

**PTR-FL**

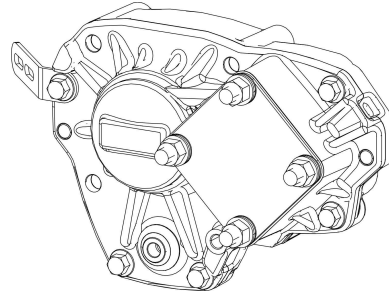

W9122052

**PTR-DM**

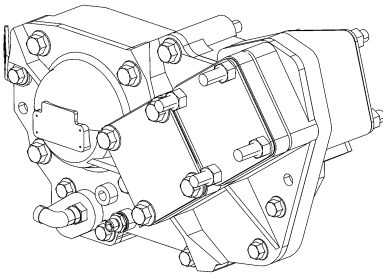

W4003060

**PTRD-D**

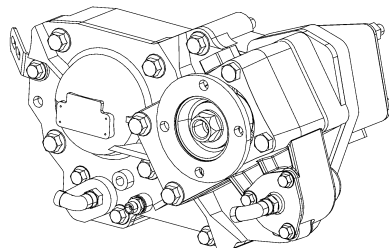

W4003061

**PTRD-D1**

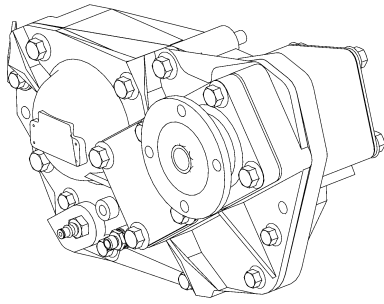

W4003059

**PTRD-F**

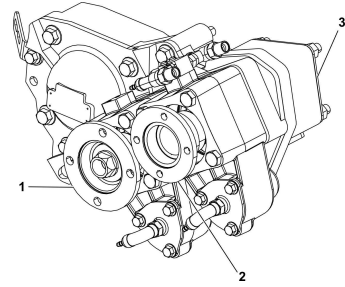

W4111374

**PTRD-D2**

PTO Drive Position on the Double and Triple PTO Housings

- 1 PTO # 1
- 2 PTO # 2
- 3 PTO # 3

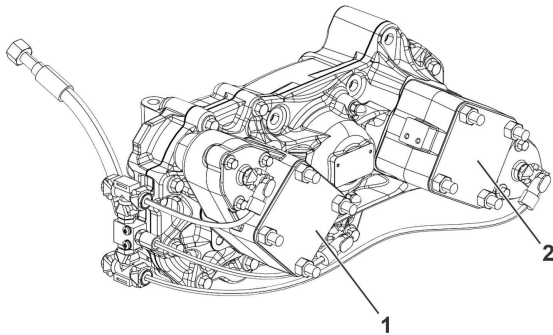

T4177370

**PTRD-D3**

- 1 DIN type PTO, LHS
- 2 DIN type PTO, RHS

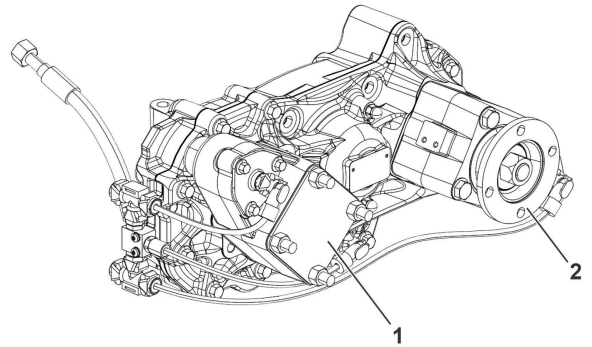

T4177371

**PTRD-D4**

PTO Drive Position on the Double

- 1 DIN type PTO, LHS
- 2 Flange type PTO, RHS

## Dual PTO Specifications

PTRD-D3 / PTRD-D4		Left-hand side	Right-hand Side	
Output Torque (Nm)		0	800	
		170	700	
		340	600	
		510	500	
		680	400	
		850	300	
		920	260	
		1000	200	
		1000	100	
		1000	0	
Output Power		95 kW (127.4 hp)	125 kW (167.6 hp)	
Weight	PTRD-D3	26.6 kg (58.6 lb)		
	PTRD-D4	31.9 kg (70.3 lb)		
Additional oil added to the transmission (due to PTO installation)		1.1 liter (1.162 quart)		
Direction of rotation		Counterclockwise (same as engine rotation)		
Ratio (RPM Output : Input)		0.85 : 1	1.43 : 1	
Total Ratio (PTO RPM : Engine RPM)	Direct Drive (DD) Transmission	Low Shift	0.60 : 1	1.01 : 1
		High Shift	0.76 : 1	1.29 : 1
	Over Drive (OD) Transmission	Low Shift	0.76 : 1	1.29 : 1
		High Shift	0.97 : 1	1.64 : 1

# Dual PTO Field Combinations

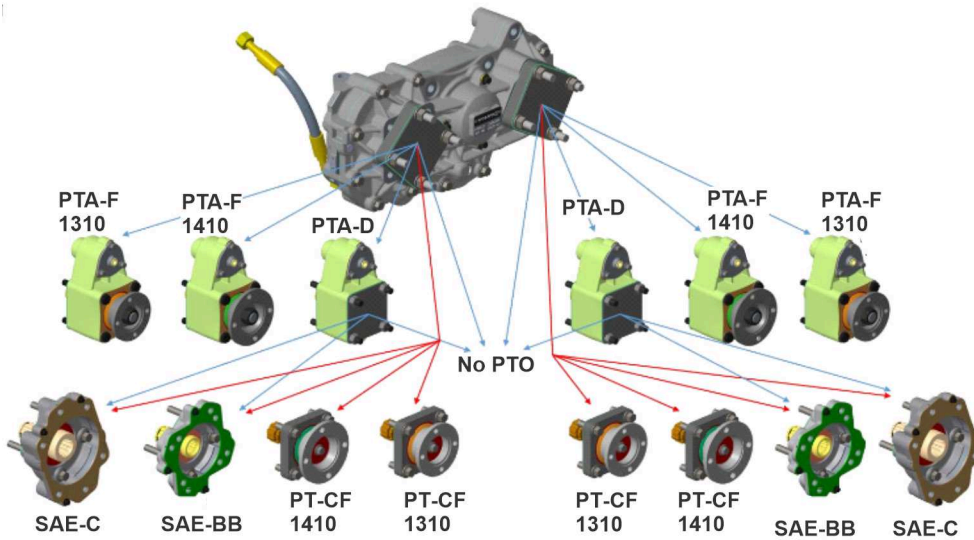

T4177369

Dual PTO	PTO type (left side)	PTO type (right side)	PTO Kit Part Number
PTRD-D3 / PTRD-D4	PTA-D <sup>1</sup>	PTA-D <sup>1</sup>	23283789
	PTA-F (SAE 1410)	PTA-F <sup>1</sup> (SAE 1410)	23283788
	PTA-F (SAE 1310)	PTA-F (SAE 1310)	23283795
	SAE-C <sup>2</sup>	SAE-C <sup>2</sup>	23283787
	SAE-BB <sup>2</sup>	SAE-BB <sup>2</sup>	23283786
	PT-CF (SAE 1410)	PT-CF (SAE 1410)	23283790
	PT-CF (SAE 1310)	PT-CF (SAE 1310)	23283791

1 Factory fitted

2 It can be installed directly on the PTO housing or through the factory-installed PTA-D.

## Dual PTO Pump Option

Dual PTO	Left-hand side PTO	Right-hand side PTO	Notes
PTRD-D3	F1 Series	F1 Series	—
	F1 Series	GP Series	—
	GP Series	F1 Series	—
	GP Series	GP Series	—
	—	F1 Series	Single pump specs always installed on right side. As needed, install an alternative output and/or reposition the pump to left side at field.
	—	GP Series	
PTRD-D4	F1 Series	PTA-F	—
	GP Series	PTA-F	—
	—	PTA-F	As needed, install an alternative output and/or reposition the pump to left side at field.

## Installation Kits

The following table outlines the installation kit necessary for installing PTO PTR-D, PTR-F, PTR-FL, PTR-DM, PTRD-F, PTRD-D on an I-Shift transmission. When installing the PTO, kit number 85135639 is necessary.

Part Number	Part Description	Quantity
1078315	Solenoid Valve	1
6795499	Nipple	2
8082135	Elbow Nipple	1
11994	Gasket	1
85114473	Tube	1
20934428	Bracket	1
20470615	Switch	1
914472	Snap Ring	2
994459	Flange Screw	4
20726050	Shaft	1
1655383	Needle Roller Bearing	1
984726	Flange Screw	2
20566049	Fitting	2
1655380	Roller Bearing	1
947099	O-ring	1
21479808	Nipple	1
963948	Nipple	1
11996	Gasket	1

The following table outlines the additional installation kit necessary for installing PTO PTRD-D1, PTRD-D2, PTRD-D3 and PTRD-D4 on an I-Shift transmission. When installing the PTO, kit number 21229046 is necessary.

Part Number	Part Description	Quantity
984726	Flange Screw	1
990949	Flange Lock Nut	1
965566	Bracket	1
21077545	Switch	1
1078315	Solenoid, Valve	1
994459	Flange Screw	1
1589391	Washer	2
984729	Flange Screw	1
984726	Flange Screw	2

## I-Shift Transmission Mounted PTO, Installation Notes

To have full functionality with PTO PTRD-D1 or PTRD-D2, it is necessary for the vehicle to be equipped with a Body Builders module (BBM) or VECU. VHD vehicles are standard with this module. To verify whether the vehicle has a VECU or a BBM, remove the Fuse and Relay Center (FRC) and look at the module located below it. VECU 5 has two rows of connectors.

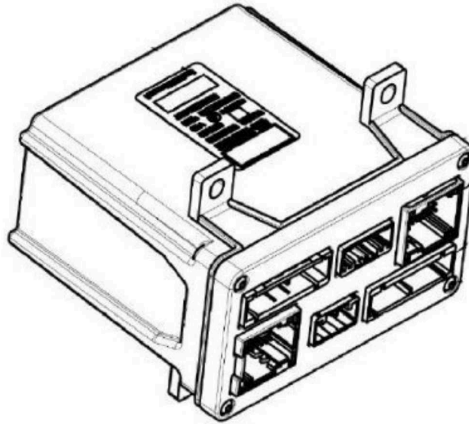

T3166836

VECU

**Note:** VECU will have 6 connectors.

**Note:** When installing an I-Shift Transmission mounted PTO, contact VOLVO Tech Support or Body Builder Support to secure the correct software for the Body Builder Module (BBM) as well as the Transmission Electronic Control Module (TECU).

# Transmission Mounted Hydraulic Pump, Installation Notes

All pumps have a Right Hand direction of rotation as seen from the PTO looking to the front of the vehicle. If installing PTO PTR-DM or PTRD-D, a supply fitting and valve are necessary.

The following is information about applicable pumps and fittings:

Application Chart					
Parker Pump Options	Displacement cc/rev (cu.in/rev)	Flow @ 800 RPM L/min (GPM)	Flow @1000 RPM L/min (GPM)	Flow @ 1200 RPM L/min (GPM)	Flow @ 1600 RPM L/min (GPM)
F1-41	2.5 (40.9)	32.9 (8.7)	40.9 (10.8)	49.2 (13)	65.9 (17.4)
F1-61	3.6 (59.5)	48.8 (12.9)	60.9 (16.1)	73.4 (19.4)	97.7 (25.8)
F1-81	5.0 (81.6)	64.7 (17.1)	81 (21.4)	97.3 (25.7)	129.8 (34.3)
F1-101	6.3 (102.9)	14.4 (54.5)	101.1 (26.7)	121.5 (32.1)	162 (42.8)
F2-42/42	A port – 42 (2.6) B port – 42 (2.6)	34.1/34.1 (9/9)	41.6/41.6 (11/11)	49.2/49.2 (3/13)	68.1/68.1 (18/18)
F2-53/53	A port – 54 (3.3) B port – 52 (3.2)	41.6/41.6 (11/11)	53/53 (14/14)	64.4/64.4 (17/17)	83.3/83.3 (22/22)

## Notes

---



---



---



---



---



---

# Layout and Specifications

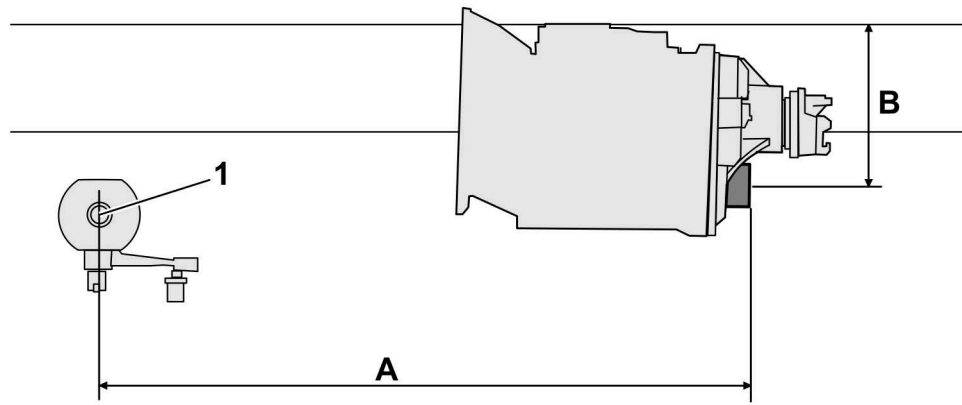

W4110727

I-Shift PTO Mounting Surface

1 Front Axle Centerline

			Transmission Model		
			AMT Direct		AMT Overdrive
Chassis	Engine	Crank Angle	A= AMT 12 Speed mm (inches)	A = AMT 13/14 Speed mm (inches)	B =Frame Rail to PTO mm (inches)
VHD-F	13L	4	1900 (74.8)	2020 (79.5)	498 (19.6)
VHD-B	13L	4	1340 (52.8)	1460 (57.9)	498 (19.6)
VNM / VNR	11L	4	1315 (51.8)	1435 (56.5)	496 (19.5)
	13L	4	1340 (52.8)	1460 (57.9)	498 (19.6)
VNL	11L	4	1315 (51.8)	1435 (56.5)	496 (19.5)
	13L	2.5	1341 (52.8)	1460 (57.9)	431 (17.0)

# Transmission-driven PTO

The transmission-driven PTO is most suitable for trucks used where work is performed while stationary. An example are vehicles equipped with dump beds or hoists. The PTO is engaged by a switch on the instrument panel. A solenoid valve opens and releases compressed air to the PTO which, in turn, meshes with a gear in the transmission.

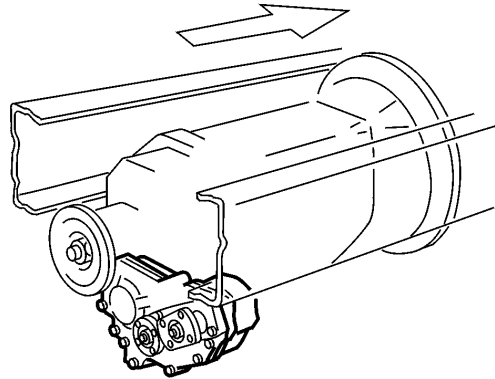

W4002395

Transmission-driven PTO

## PTO Usage

The following illustration shows a number of typical applications and the power output requirement in hp (kW) and effective operational time (1) in hours used over a 5-year period. This illustrates the relationship between different body installations and the demands placed on the PTO.

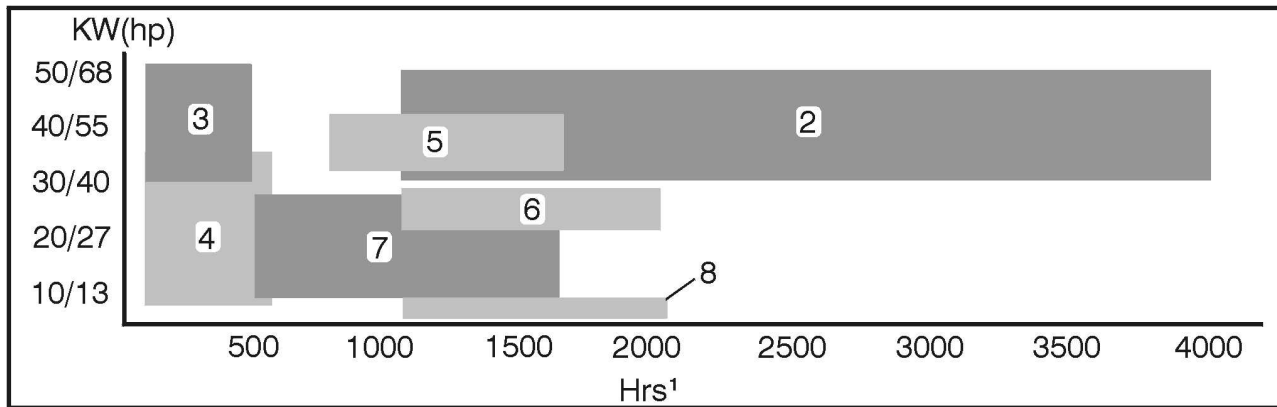

W4002383

### In-power Requirements and Hours in Operation

- |                                      |                  |
|--------------------------------------|------------------|
| 1. (Time used in hours over 5 years) | 5. Logging Crane |
| 2. Blowers                           | 6. Tank, Fuel    |
| 3. Roll-off Body                     | 7. Crane         |
| 4. Dump Truck                        | 8. Tank, Milk    |

# Power Take-off (PTO), Installation (I-Shift)

PTO kit 85135639 includes transmission drive parts, a solenoid valve, and a switch for a single PTO. PTO kit 21229046 includes an additional solenoid and switch valve for dual PTO's. Both kits are required for dual PTO's.

The electrical directions contained in this bulletin only outline the component installation and setup needed to install a single solenoid driven PTO. If installing a PTO that utilizes two separate solenoids for actuation, more extensive electrical requirements will be necessary.

## DANGER

Do not attempt to repair or service this vehicle without having sufficient training, the correct service literature and the proper tools. Failure to follow this could make the vehicle unsafe and lead to serious personal injury or death.

## DANGER

Before working on a vehicle, set the parking brakes, place the transmission in neutral, and block the wheels. Failure to do so can result in unexpected vehicle movement and can cause serious personal injury or death.

## DANGER

Before beginning any work on any part of the air system, be certain that the air pressure has been released. Failure to do so may cause a component to violently separate, which can result in serious personal injury or death.

1. Torque all fasteners using general tightening torque values unless specified in these instructions.

Fastener Size	ft-lb (Nm)
M6 standard bolt 8.8	7±1 (10±1)
M8 standard bolt 8.8	18±3 (24±4)
M10 standard bolt 8.8	35±6 (48±8)
M12 standard bolt 8.8	63±11 (85±15)
M14 standard bolt 8.8	103±18 (140±25)
M16 standard bolt 8.8	140±26 (190±35)

2. Raise and support the rear of the vehicle.

**Note:** Lift the rear of the truck until the back of the transmission has been raised 76-89 mm (3-3.5 in) to minimize transmission fluid loss.

3. Drain the air system.

4. Drain the I-Shift transmission air supply tank.

**Note:** This tank is equipped with a pressure protection safety valve and will not drain with the rest of the air system.

5. Remove the PTO mounting surface block off plate from the transmission range housing.

**Note:** Position a drain pan to capture lost transmission fluid.

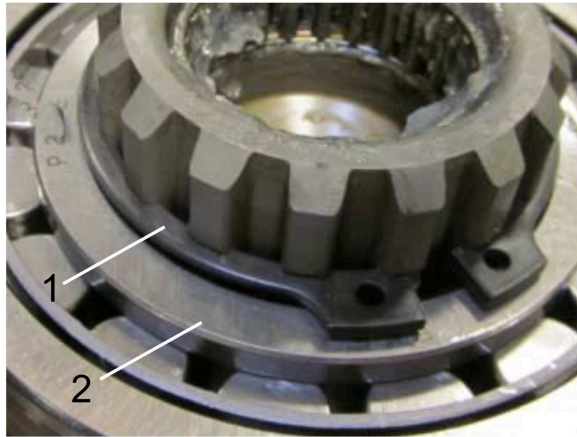

W4079510

- 1 Snap Ring
- 2 Thrust Washer

6. Assemble the PTO drive shaft assembly using the PTO drive shaft, bearing, thrust washer and two snap rings.

**Note:** Position one snap ring under the bearing and the other snap ring (1) on top of the thrust washer (2).

**Note:** Using a brass drift, gently drive the bearing into place striking only the inner race. Reposition the drift with each strike, rotating around the bearing.

## Notes

---

---

---

---

---

7. Pack the PTO drive shaft bearing with grease. **Note:** Use a synthetic based grease such as VOLVO part number 1077790 or equivalent.

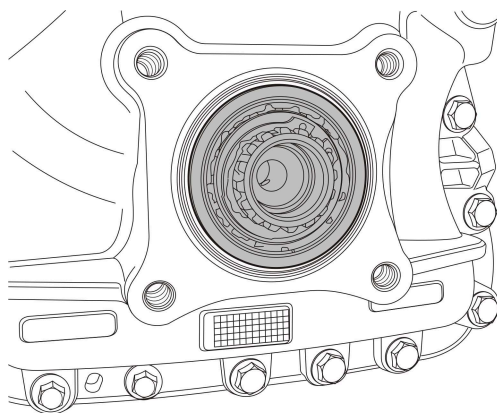

W4003016

8. Install the PTO drive shaft assembly in the transmission.

**Note:** Once positioned in the transmission, it may be necessary to gently tap the shaft in. Use a plastic or rubber faced hammer.

**Note:** The bearing is seated when the snap ring on the outside of the bearing touches the mating groove on the transmission.

9. Lubricate the PTO drive shaft pilot bearing.

**Note:** Use a synthetic based grease such as VOLVO part number 1077790 or equivalent.

10. Install the PTO drive shaft pilot bearing.

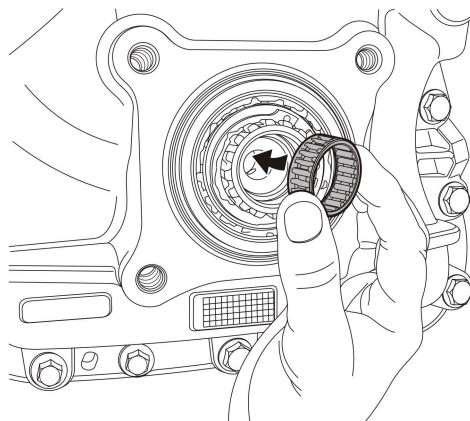

W4003017

11. Clean the PTO mating surface on the transmission, and then apply a bead of silicone sealant.

**Note:** Only use silicone to seal the PTO mating surfaces. Do not use gaskets or O-rings.

12. Install the air line bracket on the left upper PTO mounting bolt. Install the PTO and tighten the mounting bolts to  $85 \pm 5$  ( $30 \pm 4$  ft-lb).

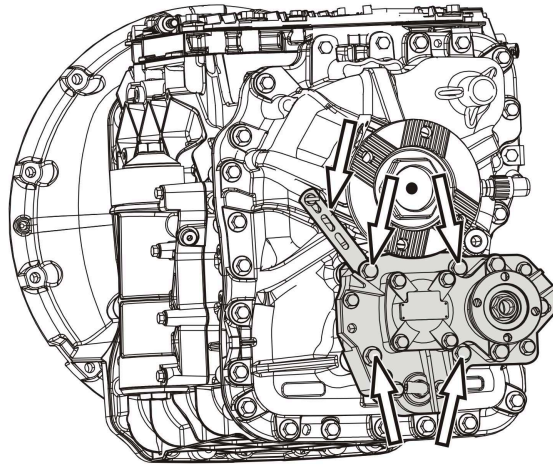

W4003020

13. Remove the PTO oil supply line plug from the back side of the transmission oil filter housing.

14. Install the oil feed line fitting into the port on the back side of the transmission oil filter housing. Torque the fitting.

**Note:** Use a copper gasket to seal the fitting

### Notes

---

---

---

---

---

15. Connect the PTO oil feed line to the oil port. Torque the line to 15 Nm (11 ft-lb).

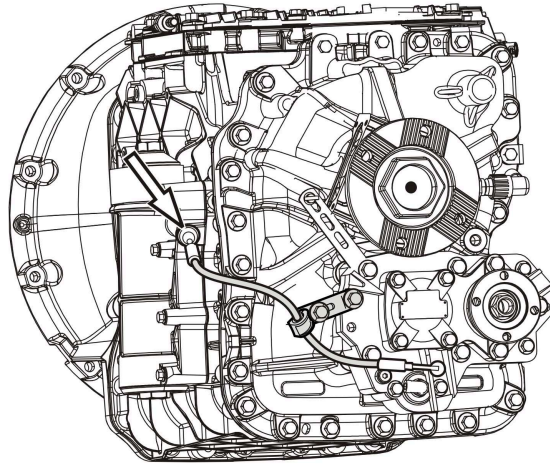

W4003018

16. Locate the PTO solenoid wiring harness connectors tied to the transmission wiring harness on top of the transmission. Cut tie straps as needed to free the harness for use.

**Note:** The wiring tags should read PTO1 and PTO2 at the connectors.

**Note:** PTO1 wiring numbers are NA11A1 and NA20A1. PTO2 wiring numbers are NA16A1 and NA17A1.

17. For a single PTO, install two quick connect air fittings and one pipe plug into the PTO solenoid. For dual PTOs, install an O-ring between the solenoids in place of the pipe plug.

**Note:** The supply line fitting should accept a 9.5 mm (3/8 in) air line, and the outlet fitting should accept a 6.35 mm (1/4 in) air line.

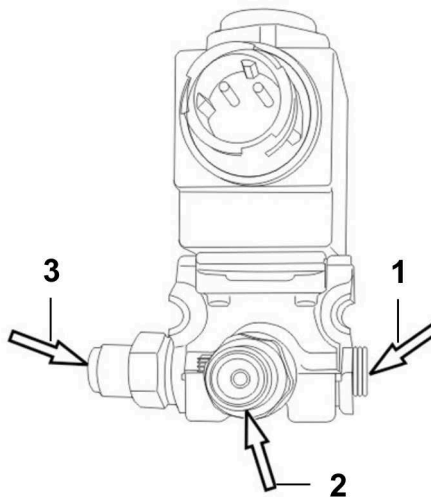

W9123394

- 1 Plug for single or O-ring for dual
- 2 Outlet fitting 1/4"
- 3 supply line 3/8"

18. Install the PTO solenoid to the bracket and torque the bolts to 9 Nm (80 in-lb).

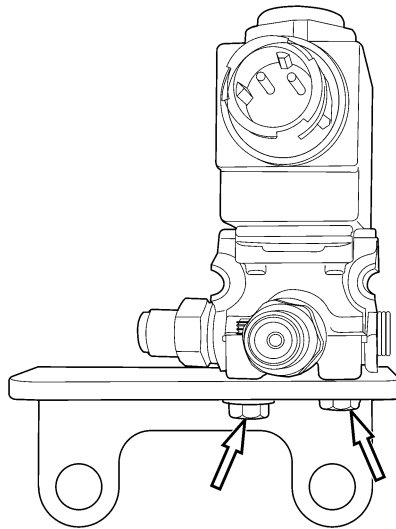

W4003027

19. Remove the two, top left range housing mounting bolts.

20. Install the PTO solenoid bracket using the range housing bolts. Torque the bolts to 110 Nm (81 ft-lb).

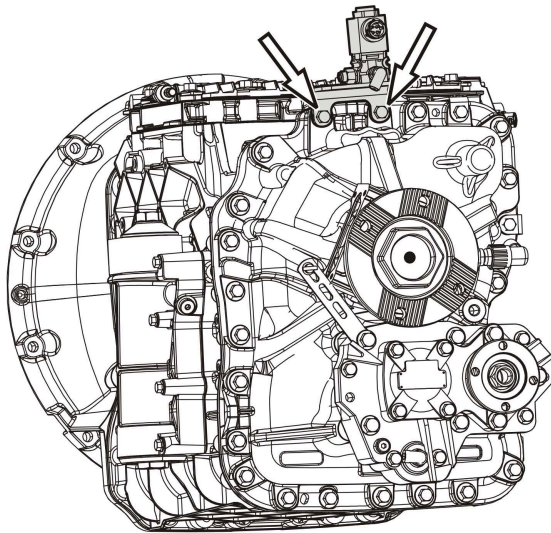

W4003019

21. Connect PTO1 wiring harness to the solenoid.

**Note:** The wiring tags should read PTO1 and PTO2 at the connectors.

**Note:** PTO1 wiring numbers are NA11A1 and NA20A1. PTO2 wiring numbers are NA16A1 and NA17A1.

22. Install a 90° air line quick connect fitting into the PTO.

**Note:** The fitting should accept a 6.35 mm (1/4 in) air line.

23. Install a 6.35 mm (1/4 in) inch air line from the solenoid to the PTO.

**Note:** Route the air line away from the moving parts and secure to the mounting bracket with tie straps.

24. Remove the plug from the available 9.5 mm (3/8 in) inch air line port on the pressure protection manifold, found on the left inner frame rail.

25. Install the solenoids. Install the 9.5 mm (3/8 in) air supply line to the pressure protection manifold and then connect it to the solenoid.

**Note:** Route the air line away from any moving parts and secure using tie straps.

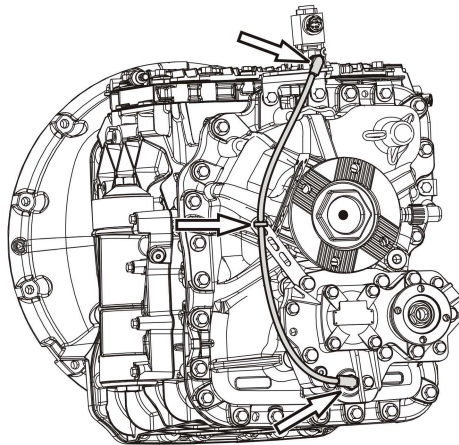

W4003022

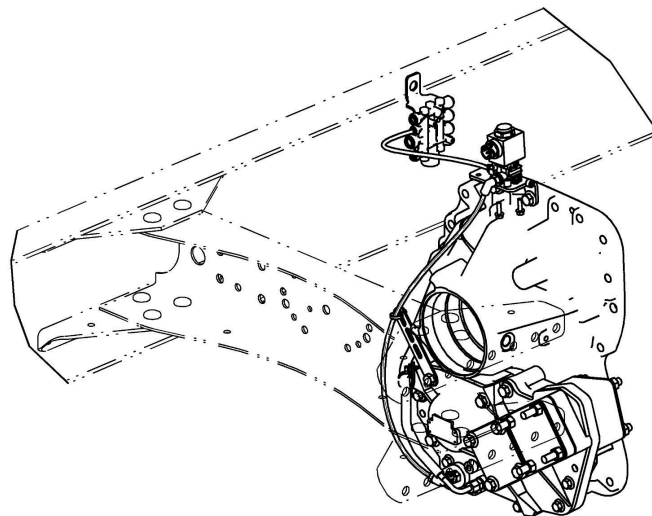

W9123652

26. Remove the plug from the available 3/8-inch air line port on the pressure protection manifold (found on the left inner frame rail). Insert the air line and route it to the solenoid inlet 3/8 port.

27. Pressurize the air system and check for leaks.

**Note:** If any leaks are found, drain the air tank and repair the leak. Re-test until no leaks are found.

28. Remove the supports and lower the vehicle.

29. Should the transmission require additional oil see charts below.

Park the vehicle on a level surface and check the transmission oil level through the sight glass on the right side of the transmission. Add Volvo-approved synthetic transmission oil as needed. Note that the drain plug indicates the type of oil used in the transmission.

Silver Drain Plug	85146530, SAE50 I-Shift Heavy Duty
Brass Drain Plug	VPO120549, 75W-80 I-Shift Standard

### Volvo Oil Types and Part Numbers

Oil Weight	Part Number and Alternative
SAE50	85146530 or Mobile Delvac Synthetic Transmission Oil V50
75W-80	VPO120549 or Mobile Delvac Synthetic Transmission Oil V30

### Notes

---

---

---

---

---

---

**Note:** Fill the transmission until the fluid level is between minimum and maximum of the sight glass.

**Note:** Do not reuse old oil from the I-Shift transmission. Always use new oil when filling.

**Note:** 1–2 L (1–2.1 qt) of fluid may be lost during the installation.

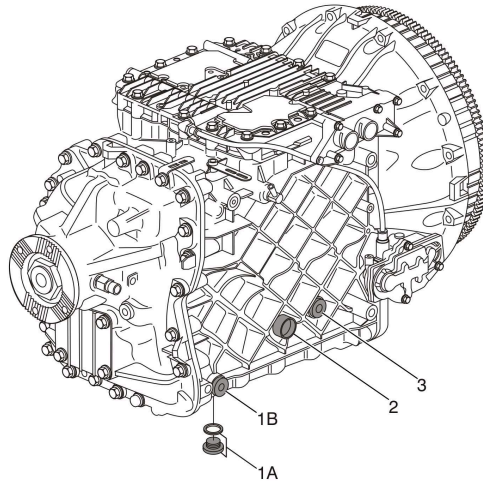

W4002904

- 1A Drain plug
- 1B Drain plug
- 2 Sight glass
- 3 Fill plug

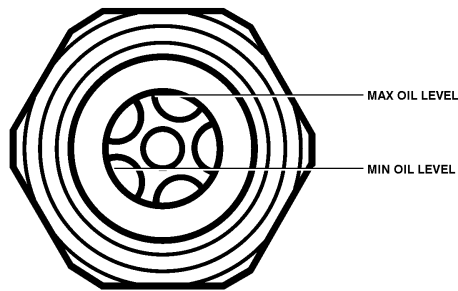

T4021684

- 30. Remove the bussed electrical center (BEC) cover in the cab.
- 31. Install a 5 amp fuse in fuse location F34 of the FRC.

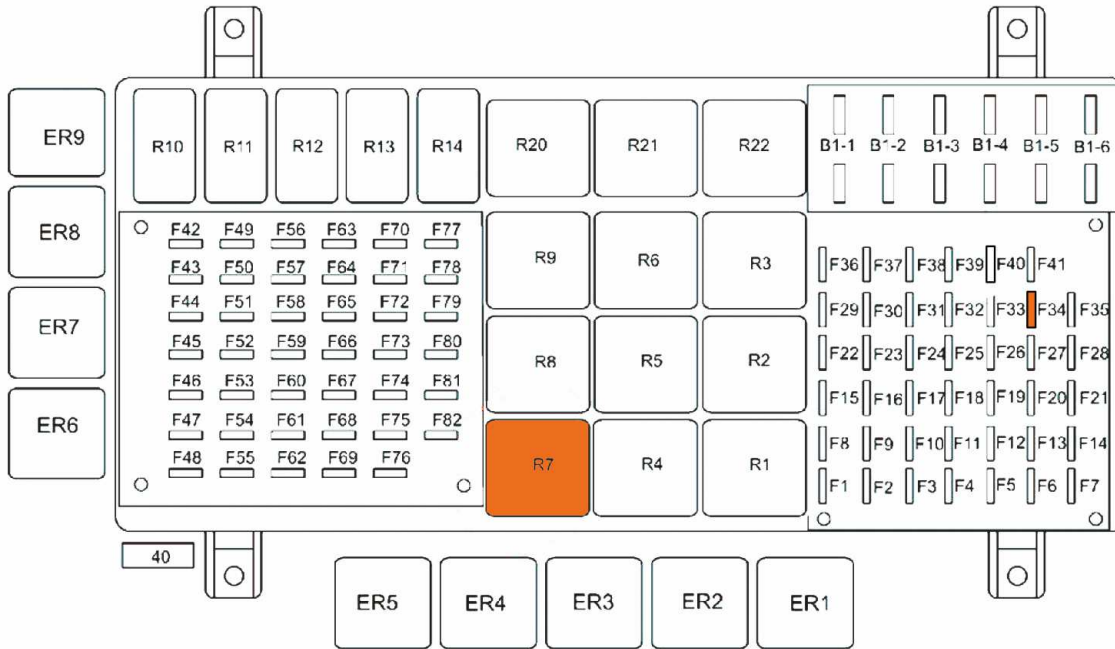

T3192613

**Note:** The above illustration is for Gen I FRC.

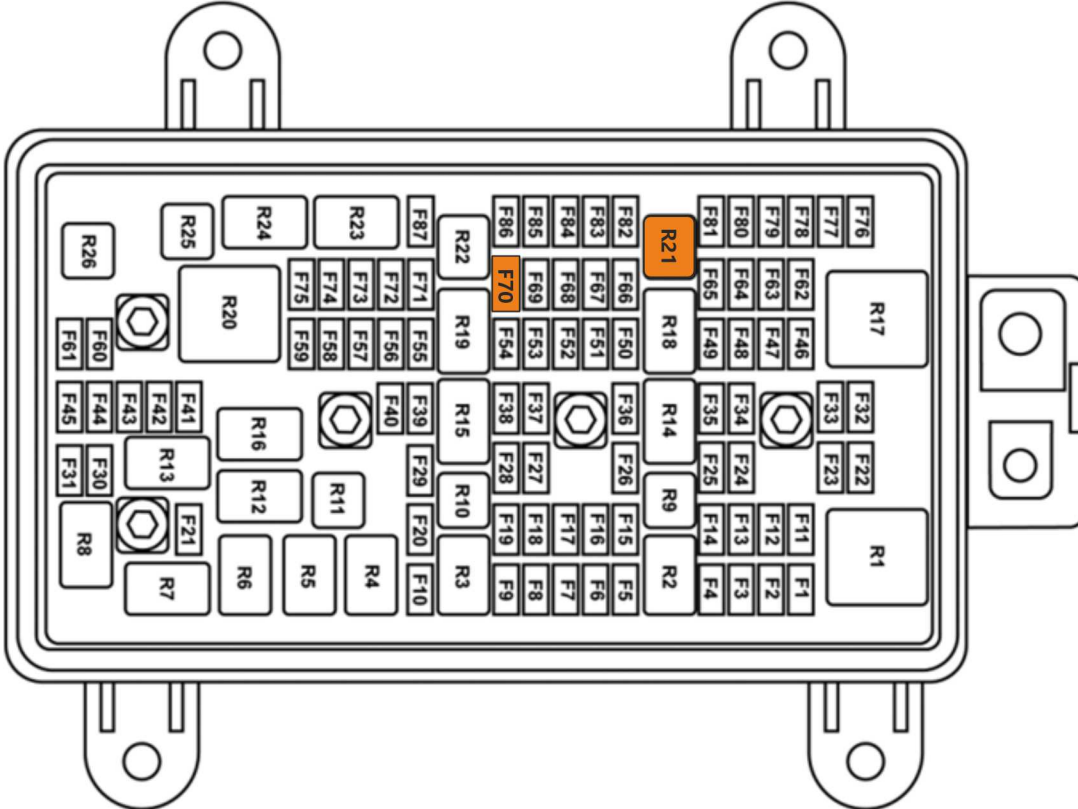

T3192614

**Note:** The above illustration is for Gen II, PTO fuse location is F70 and relay is R21

32. Install relay in location R7 of the Gen I FRC.

33. Install the BEC cover.

34. Remove the dash switch blank from either position 3 or 5 on the dash board. The PTO switch connector is in the cab wiring harness and should be located behind this general location.

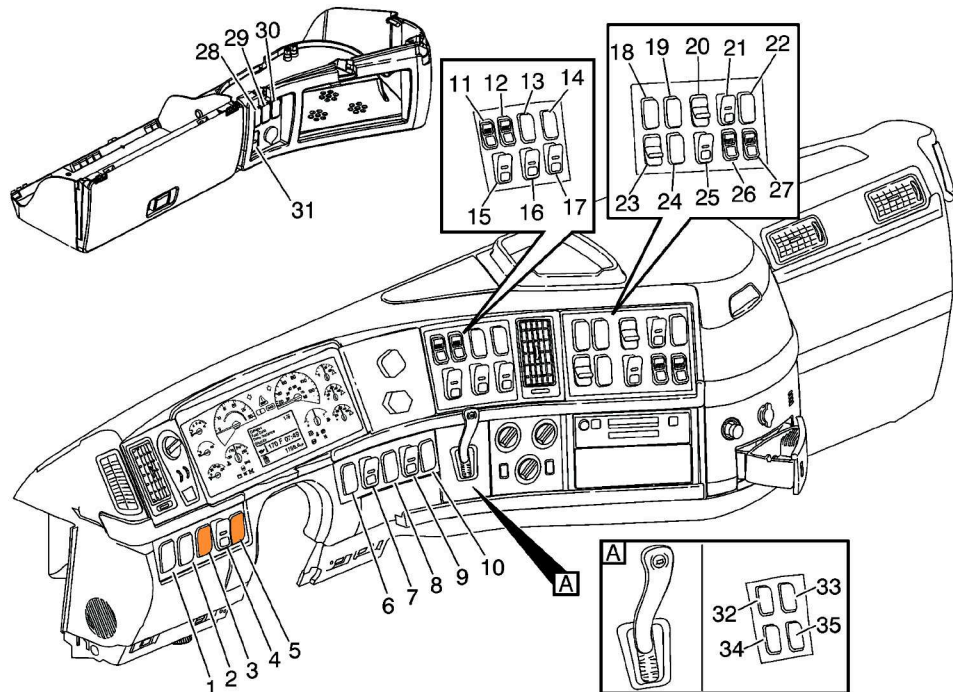

W9118873

35. Install the PTO switch (20470615) in position 3 or 5, depending on which location is available.

36. Using the scan tool, flash the transmission control module (TCM) with the appropriate software for a single PTO. Contact the help desk for further assistance.

**Note:** The appropriate software is dependent upon how many solenoids are being used to actuate the PTO (single or dual solenoids), not the outputs on the PTO.

37. After the TCM has been flashed with its software, it is necessary to perform the "Transmission and Clutch Calibration" using the scan tool.

38. Perform PTO parameter programming. For more information, refer to the "PTO Programming" bulletin found in the electrical section of the Body Builders Manual.

**Note:** It will be necessary to change the vehicle electronic control unit Vehicle ECU default parameter for PTO position mounting from **engine1** to **transmission1**.

39. Run the vehicle and re-check the transmission fluid level. Top off the transmission as needed so the fluid level is between minimum and maximum of the sight glass.

**Note:** The PTO shares the transmission fluid for lubrication. The PTO will retain about .75 liters (.8 qts.), of transmission fluid after initially being run. Always top off the transmission fluid after installing a new PTO.

# Diesel Exhaust Fluid (DEF) Cooling Lines, Side Mounted PTO

This kit is being released in order to provide a solution for customers requiring a side mounted PTO on mechanical transmissions. Currently, if a PTO is mounted on the transmission it will interfere with the urea cooling lines that are routed down the right side of the frame. This kit allows the customer to remove the hard piping associated with the urea cooling lines and replace them with flexible hoses that prevents the previously mentioned interference.

Mechanical Transmission PTO Cooling Line Routing Kit					
D13 Contents 85124281			D11 Contents 85124282		
Part Number	Part Description	Quantity	Part Number	Part Description	Quantity
990536	Rubber Hose	2	990536	Rubber Hose	1
20437238	Cable Tie	3	990536	Rubber Hose	1
965541	Bracket	2	20437238	Cable Tie	2
965559	Bracket	3	965541	Bracket	2
965560	Bracket	1	965559	Bracket	3
981664	Clamp	6	965560	Bracket	1
984733	Flange Screw	5	981664	Clamp	6
990950	Lock Nut	5	984733	Flange Screw	5
984753	Flange Screw	3	990950	Lock Nut	5
990951	Lock Nut	3	984753	Flange Screw	3
20805109	Connector	2	990951	Lock Nut	3
984992	Hose Clamp	2	20805109	Connector	2
			984992	Hose Clamp	2

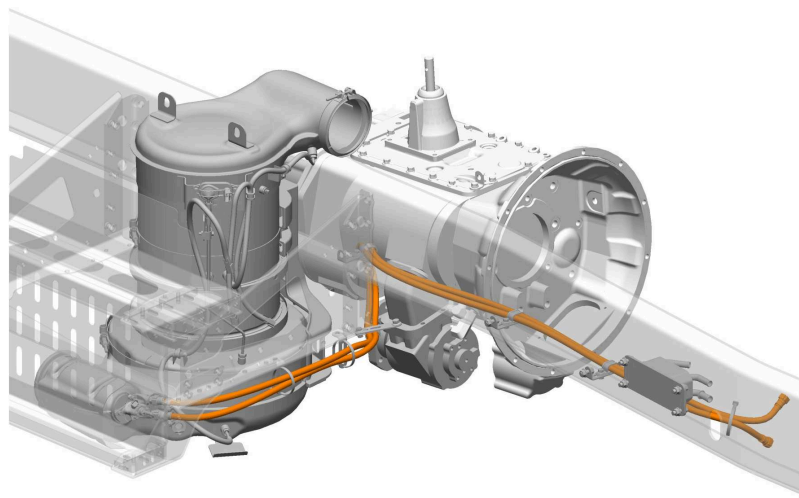

W2037255

Cooling Line Routing

# Engine Mounted Power Take-off

## REPTO (Rear Engine Mounted Power Take-off)

Volvo offers the REPTO (clutch independent) for the D11 and D13 engines that are capable of handling a single DIN or Flange drive.

The VOLVO REPTO is a clutch-independent PTO, and the engine timing gear drives it. It receives power directly from the engine. It is suitable to use both when the vehicle is running as well as in a parked condition. It is also suitable for a vehicle that requires engagement and disengagement from outside of the vehicle.

It is always more cost effective to order an engine with the REPTO installed at the time the engine is built. If an engine is not built with REPTO, it is also possible to install a PTO as an aftermarket upgrade. For vehicles that require constant access to PTOs, clutch independent PTO is the only option.

**Note:** When the PTO is driving a hydraulic pump, a bypass valve is required to control hydraulic fluid flow.

**Note:** To provide a dual hydraulic circuit with a single engine-mounted PTO, use a dual-flow hydraulic pump such as the Parker F2 series. The dual-flow hydraulic pump is the only option available for a single engine-mounted PTO to have a dual hydraulic circuit.

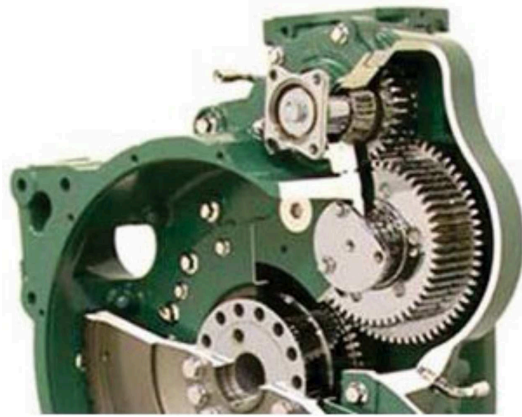

W9116666

Speed ratio: 1:X.x (1 = engine, X.x = power take-off)

Engine	Power Take-off Type	Weight lbs.	PTO Drive Type		Speed Ratio	Direction of rotation <sup>1</sup>	Max permissible torque ft-lb (Nm) <sup>2</sup>	Power take-off
			Type	Dimension				
D11	PTER-DIN	66.0	Direct	DIN 5462	1:1.08	 (Same as engine) <sup>1</sup>	< 5 km/h (3 mph) 1000 (738) > 5 km/h (3 mph) 650 (479)	PTR-xxx
	PTER-1400	34.0	Flange	SAE 1410	1:1.26			
D13	PTER-DIN	66.0	Direct	DIN 5426	1:1.26		> 5 km/h (3 mph) 650 (479)	PTR-XXX + EPTT650
	PTER-1400	34.0	Flange	SAE 1410			< 5 km/h (3 mph) 1000 (738)	PTR-XXX + EPTT1000

<sup>1</sup> Counterclockwise when facing the back of the engine

2 The engagement of the hydraulic pump must not give any pressure peaks exceeding the rated pressure.

**Note:** Low stiffness of the propeller shaft and inertia on the pump give low resonance frequency to the PTO. Engine frequency triggers the low resonance frequency. To avoid the occurrences of pressure peaks, measure the pressure close to the pump and adjust the PTO engagement time.

## Resonance Frequency



### CAUTION

For the propeller shaft to PTO pump, the minimum torsional resonance frequency is 300 Hz. Failure to follow this may cause severe engine component damage.

Resonance frequency ( $f$ ) for a propeller shaft driven PTO is calculated as:

$$f = \frac{1}{2 \times \pi} \times \sqrt{\frac{k}{J}}$$

$f$  = resonance frequency (Hz)

$k$  = stiffness of prop shaft and coupling(s) (Nm/rad)

$J$  = hydraulic pump and coupling mass moment of inertia (kgm<sup>2</sup>)

*Example:*

$k = 2,8 \times 10^5$  Nm/rad

$J = 0,05$  kgm<sup>2</sup>

$$f = \frac{1}{2 \times \pi} \times \sqrt{\frac{2,8 \times 10^5}{0,05}} = 377 \text{ Hz}$$

## REPTO Application

The REPTO is ideally suited to the following applications:

- Concrete Mixer – Typically a driveshaft connection is used in this application to drive the pump. The pump is part of the mixer body installation.
- Snow Plow – Typically a direct connect single or dual valve pump to power the plow blade and salt spreaders.
- Refuse – Typically a direct connect single or dual valve pump to power the body packer between collections.

# REPTO with Splined Shaft Groove (Female) DIN 5462

REPTO with splined groove is a clutch-independent PTO. It takes power directly from the engine, and the timing gear drives it. It is suitable for use both when the vehicle is running as well as in a parked condition. It is also suitable for a vehicle that requires engagement and disengagement from outside of the vehicle.

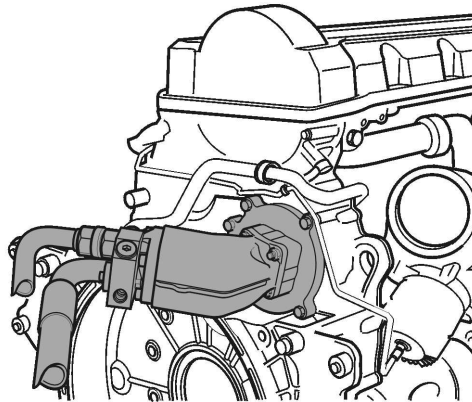

T4019448

Shown with optional direct mount pump

## Notes

---

---

---

---

---

## REPTO with Flange SAE 1410/ ISO 7647

REPTO with flange is a clutch-independent PTO. A SAE 1400 flange connection is used for shaft driven accessories. It takes power directly from the engine, and the timing gear drives it. It is suitable for use both when the vehicle is running as well as in a parked condition. It is also suitable for a vehicle that requires engagement and disengagement from outside of the vehicle.

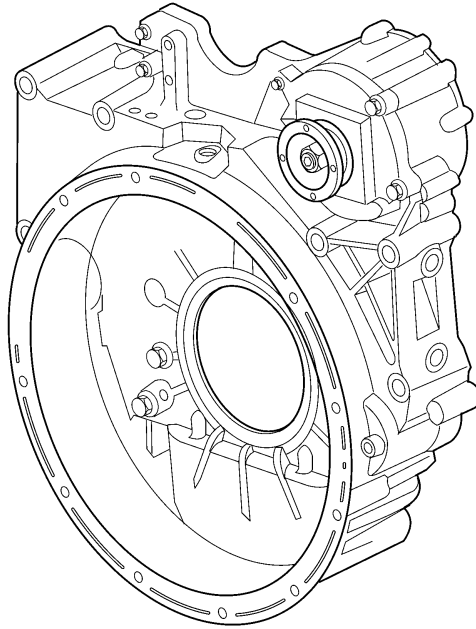

W4002977

Rear-Mounted Engine PTO (D13 engine)

### Notes

---

---

---

---

---

# SAE Flanges

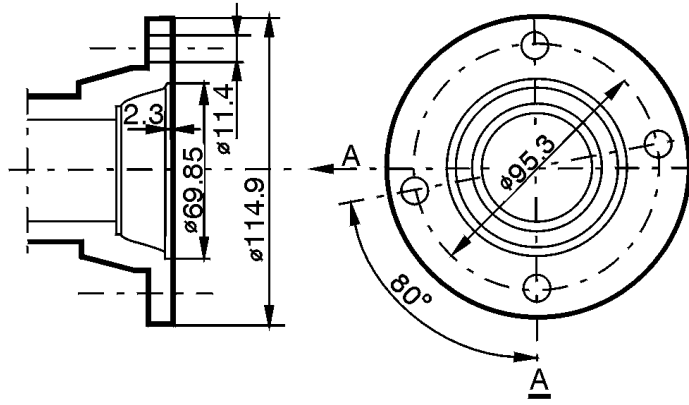

W4002386

Flange SAE 1400

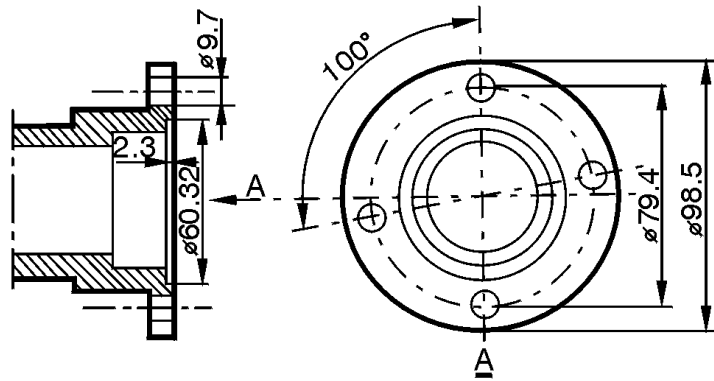

W4002387

Flange SAE 1300

# REPTO Access

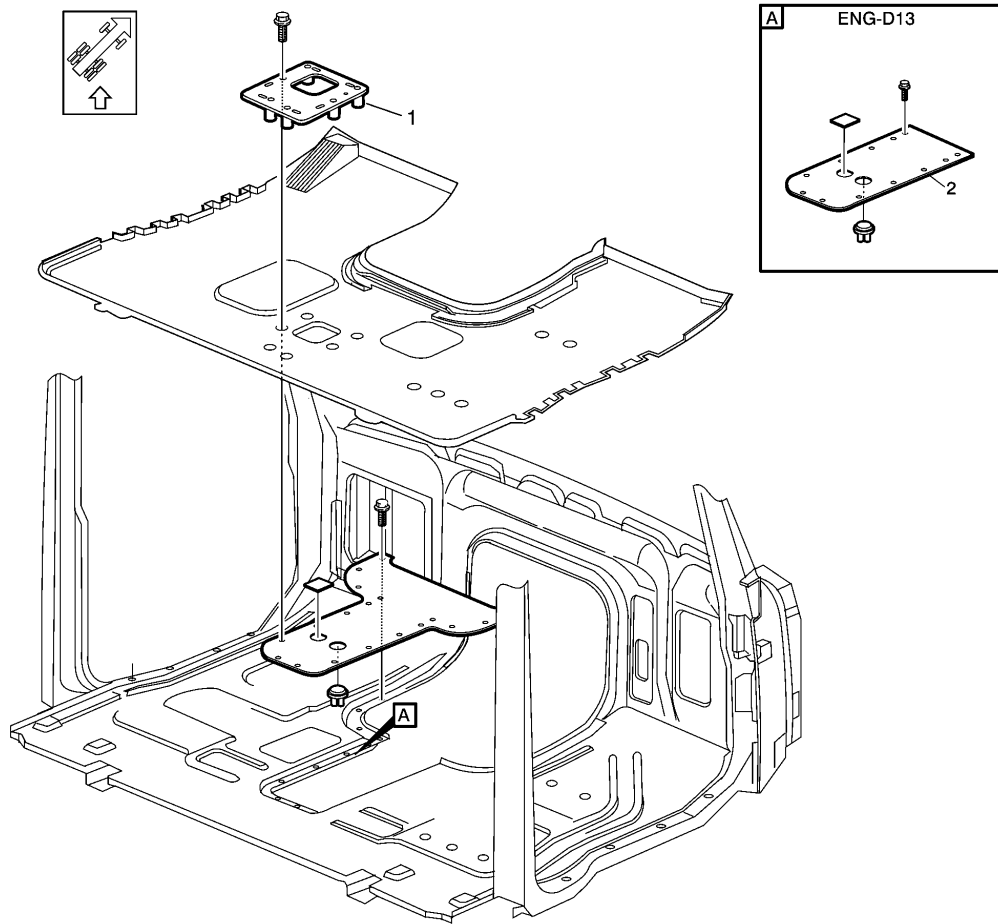

W9056051

- 1 Control plate for REPTO 20395950
- 2 Engine Access Plate(s)
- A Location of Engine Access Plate(s)

**Note:** To remove the engine access plate, remove the Floor mat and Passenger Seat.

# REPTO, Installation

When installing a REPTO on a D11 or D13 engine, use the following parts information.

PTO Spline	Part Number	Description	QTY
D11F DIN	23496058	REPTO Unit	1
	976068	O-Ring	1
	984850	Bolt	2
	984820	Bolt	2
D11F SAE	23343592	REPTO Unit	1
	976068	O-Ring	1
	984850	Bolt	2
	984820	Bolt	2
D13F DIN	23496052	REPTO Unit	1
	976068	O-Ring	1
	984762	Bolt	1
	984816	Bolt	3
D13F SAE	21913220	REPTO Unit	1
	976068	O-Ring	1
	984762	Bolt	1
	984816	Bolt	3
	22066340	Protecting Screen	1

## Notes

---



---



---



---



---

# REPTO

Trucks used for certain applications, such as cement mixers or dump trucks, may have a REPTO equipped. PTOs of this type are installed on the rear of the engine, and timing gear drives it. They are intended for use when the vehicle is moving or stationary.

REPTOs are designed to accomplish a number of performance-related objectives:

- They have eliminated unnecessary parts (e.g., additional Front-mounted PTO equipment).
- They deliver efficient, clutch independent power.
- They allow specification of a lengthened wheelbase without exceeding overall length restrictions.

Example: two trucks with the same frame length must meet the same overall length of 10 m (40 ft). The truck with a front engine-mounted PTO requires a hydraulic pump in front of the cab (or bumper). Thus limits the wheelbase approximately 46 – 53 cm (18 – 21 in) compared to the vehicle with REPTO. This results in an increase in payload under the federal Bridge Law of 545 – 680 kg (1200 – 1500 lb).

This performance is possible because REPTOs are designed as an integral bearing housing that is mounted on the right, rear of the engine.

**Note:** The REPTO rotates in the same direction as the engine.

**Note:** The REPTO access hatch is tied to the REPTO variant. Whenever a REPTO is requested the access hatch is provided. Therefore, the customer does not need to request the hatch.

Benefits of REPTO include:

- Eliminate the need for extended frame or bumper.
- Permits shorter hydraulic lines.
- Simplifies maintenance (REPTO need not be removed for clutch service)
- Eliminates need for modification to radiator and radiator supports for PTO shaft clearance.

REPTOs permit the operator to engage or disengage the PTO even when the vehicle is moving. Unlike transmission mounted PTOs, REPTOs are dependent only on the engine.

VOLVO D11 Specifications		
Location	Right rear side of engine gear train	
Type	Clutch independent power take-off	
Housing Material	Cast iron	
Flange Connection	SAE 1350/1410 4 — Bolt	
DIN Mounting	5462/ISO 7653	
Engine	D11	
Gear Ratio (Engine:PTO)	DIN5462	1:1.08
	SAE 1350/1410	1:1.26
Max Torque — Stationary	630 ft-lb (850 Nm)	
Max Torque — >5 kph (3 mph)	480 ft-lb (651 Nm)	
Weight	10.9 kg (24 lb)	

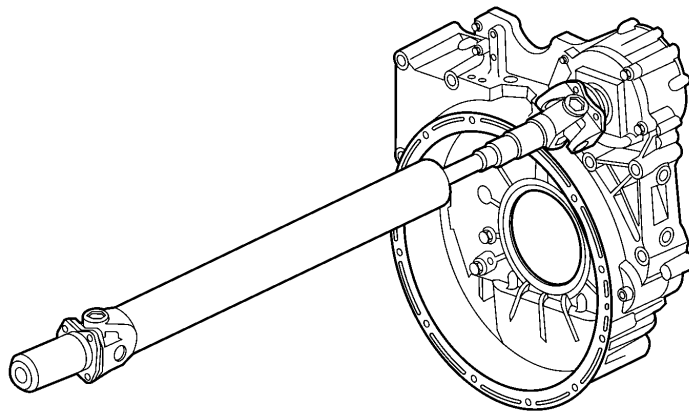

W4002976

REPTO (D11/D13 engine)

VOLVO D13 Specifications		
Location	Right rear side of engine gear train	
Type	Clutch independent power take-off	
Housing Material	Cast iron	
Flange Connection	SAE 1350/1410 4 — Bolt	
DIN Mounting	5462/ISO 7653	
Engine	D13	
Gear Ratio (Engine:PTO)	SAE 1350/1410	1:1.26
	DIN 5462	
Max Torque — Stationary	740 ft-lb (1003 Nm)	
Max Torque — >5 kph (3 mph)	480 ft-lb (651 Nm)	
Weight	14 kg (31 lb)	

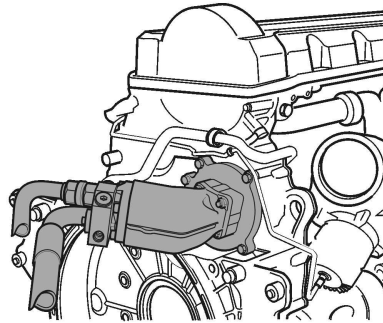

T4019448

REPTO (D11/D13 engine)

### Hydraulic Pump Flow D11 Engine, (GPM) at Pump Speed (rpm)

Parker/VOAC Pump <sup>1</sup>	Ratio	Pump Speed (rpm)					
		800 L/min (gpm)	900 L/min (gpm)	1000 L/min (gpm)	1200 L/min (gpm)	1400 L/min (gpm)	1600 L/min (gpm)
F1-61	1:1.08	51 (13.5)	58 (15.3)	64 (16.9)	77 (20.3)	90 (23.8)	103 (27.2)
F1-81	1:1.08	71 (18.8)	79 (20.9)	88 (23.2)	106 (28.0)	123 (32.5)	141 (37.2)
F1-101	1:1.08	89 (23.5)	100 (26.4)	111 (29.3)	133 (35.1)	156 (41.2)	178 (47.0)
F2-42/42	1:1.08	37/35 (9.8/9.2)	42/40 (11.1/10.6)	46/44 (12.2/11.6)	56/53 (14.8/14.0)	65/62 (17.2/16.4)	74/71 (19.5/18.8)
F2-53/53	1:1.08	47/45 (12.4/11.9)	52/51 (13.7/13.5)	58/56 (15.3/14.8)	70/67 (18.5/17.7)	82/79 (21.6/20.9)	93/90 (24.6/23.8)

## Hydraulic Pump Flow D13 Engine, (GPM) at Pump Speed (rpm)

Parker/VOAC Pump <sup>1</sup>	Ratio	Pump Speed (rpm)					
		800 L/min (gpm)	900 L/min (gpm)	1000 L/min (gpm)	1200 L/min (gpm)	1400 L/min (gpm)	1600 L/min (gpm)
F1-61	1:1.26	51 (13.5)	58 (15.3)	64 (16.9)	77 (20.3)	90 (23.8)	103 (27.2)
F1-81	1:1.26	71 (18.8)	79 (20.9)	88 (23.2)	106 (28.0)	123 (32.5)	141 (37.2)
F1-101	1:1.26	89 (23.5)	100 (26.4)	111 (29.3)	133 (35.1)	156 (41.2)	178 (47.0)
F2-42/42	1:1.26	37/35 (9.8/9.2)	42/40 (11.1/10.6)	46/44 (12.2/11.6)	56/53 (14.8/14.0)	65/62 (17.2/16.4)	74/71 (19.5/18.8)
F2-53/53	1:1.26	47/45 (12.4/11.9)	52/51 (13.7/13.5)	58/56 (15.3/14.8)	70/67 (18.5/17.7)	82/79 (21.6/20.9)	93/90 (24.6/23.8)

## BOC (Back Of Cab) Crossmember For REPTO with/without Mixer Body Plates

### Sales Code:

- OA-AC BOC crossmember for PTO with mixer plates
- OA-AD BOC crossmember for PTO without mixer plates
- AX-AA Flip overhang crossmember upside down

The following offerings are available in VHD models with REPTO or Allison PTO configurations for mixer use:

- BOC crossmember for PTO with mixer plates (OA-AC)
- BOC crossmember for PTO without mixer plates (OA-AD)
- Intermediate crossmember

These options allow body companies to mount the mixer PTO pump on the VOLVO crossmember.

The following options are offered to the vehicle with mixer booster axle for better cylinder clearance:

- An inverted intermediate overhang crossmember
- Flip overhang crossmember upside down (AXAA)

**Note:** For the vehicle with mixer booster axle, the intermediate overhang crossmember is mounted upside down to prevent the mixer cylinder from interfering.

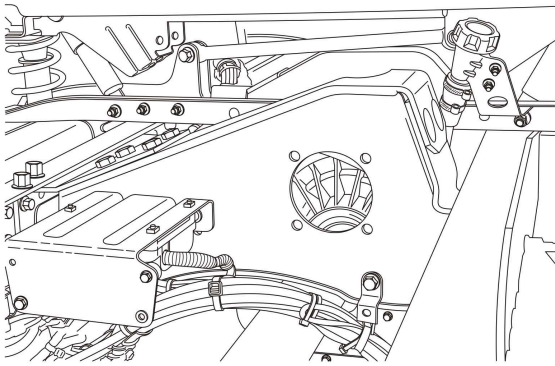

W9000809

Crossmember

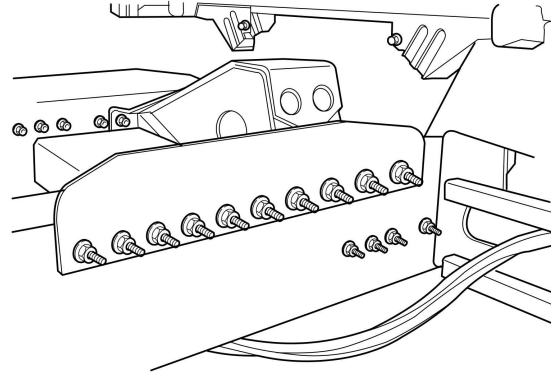

W9000848

Crossmember and Body Plate

## Front-mounted Engine PTO

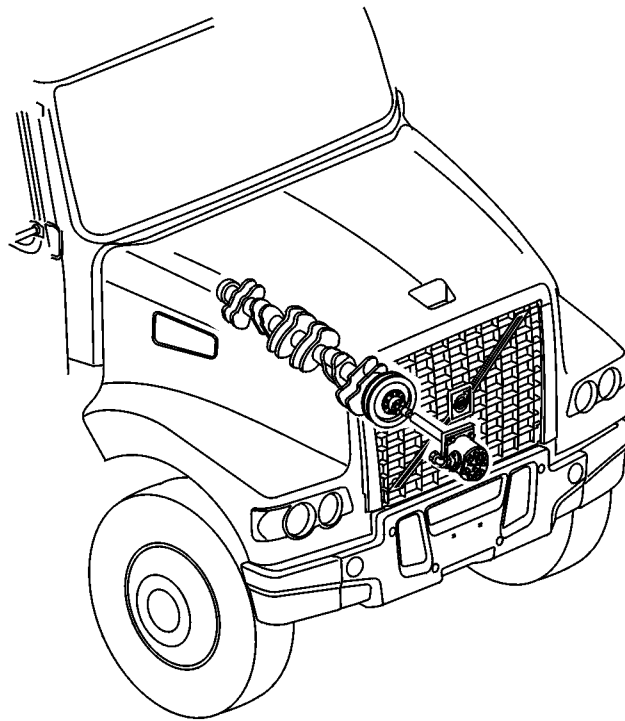

W4002398

The front-mounted PTO is suitable for the following applications:

- Refuse
- Dump body with spreading apparatus
- Roll on/off, hook lifts
- Municipality trucks with multiple hydraulic equipment needs, snow plows, cranes, dump bodies, etc.

# Front PTO Configuration, Axle Back

## Volvo VHD Only

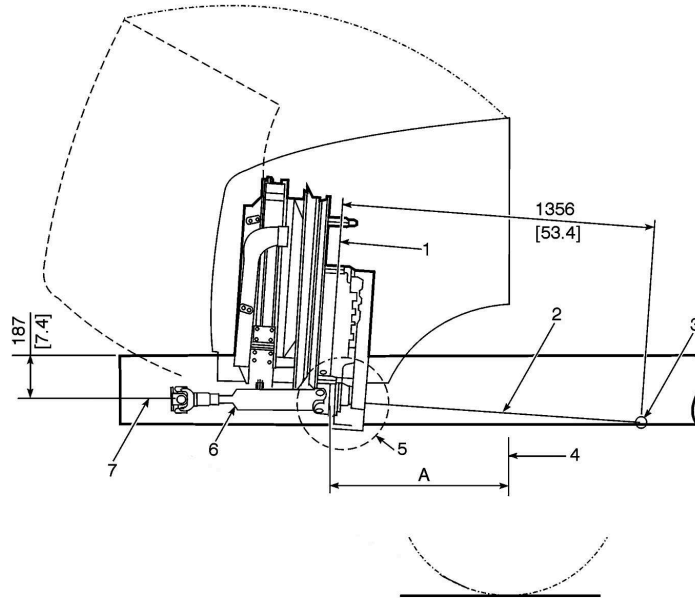

W9116879

Fig. 1 Front PTO, Axle Back, With 930 Sq. in. Radiator

- 1 PTO shaft mounting surface.
- 2 Centerline of crankshaft at 4°.
- 3 Position of engine rear face of flywheel housing.
- 4 Centerline of front axle.
- 5 See Fig. 4 on page 49 .
- 6 1410 Series shaft shown.
- 7 Centerline of PTO driveshaft (horizontal)
- A Dimension (see table below)

Dimension	Axle Forward mm (in.)	Axle Back mm (in.)
<b>A</b>	220 (8.7)	778 (30.6)

**Max Torque** 678 Nm (500 ft-lb)

**Max Power** 134 kW (180 hp) @ 1800 rpm

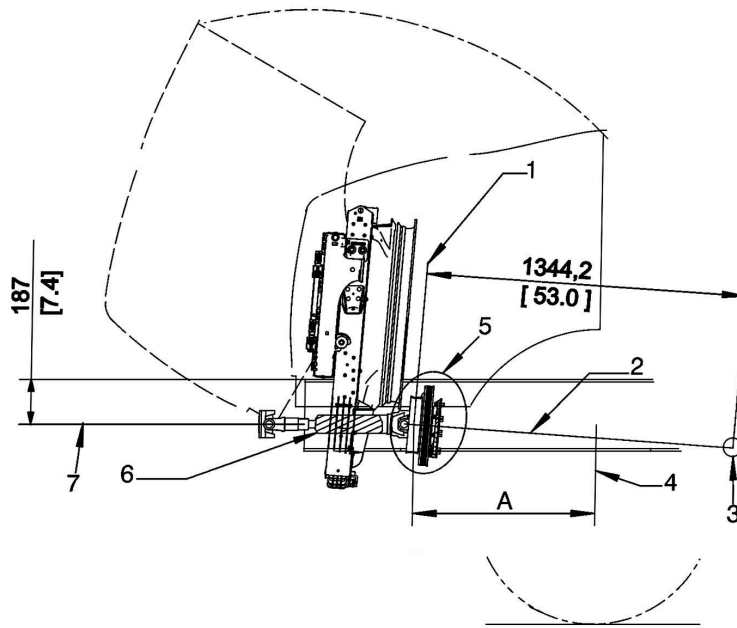

W9116880

Fig. 2 Front PTO, Axle Back, With 1240 Sq. in. Radiator

- 1 PTO shaft mounting surface.
- 2 Centerline of crankshaft at 4°.
- 3 Position of engine rear face of flywheel housing.
- 4 Centerline of front axle.
- 5 See Fig. 6 on page 50 .
- 6 1410 Series shaft shown.
- 7 Centerline of PTO driveshaft (horizontal)
- A Dimension (see table below)

Dimension	Axle Forward mm (in.)	Axle Back mm (in.)
<b>A</b>	206 (8.1)	766 (30.2)

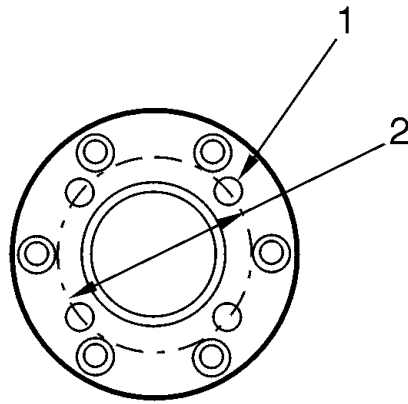

W4002367

Fig. 3 Adapter PTO Drive Coupling (1350/1410), 1:2

- 1 4 x 7/16 — 20UNF-2B
- 2 95.25 PC Diameter

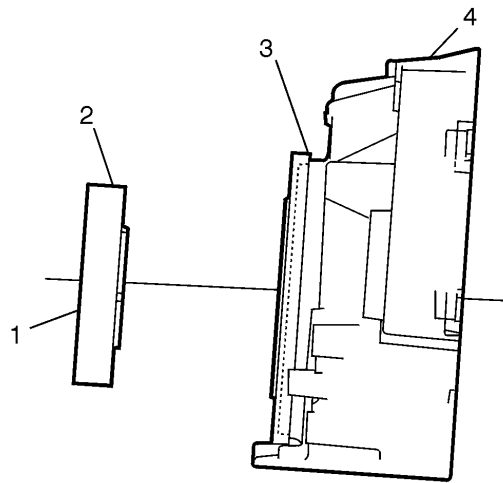

W4002368

Fig. 4 Exploded View, Front PTO Drive Adaptation, With 930 Sq. in. Radiator 1:2

- 1 PTO Shaft Flange Mounting Surface
- 2 Adapter PTO Drive Coupling
- 3 Companion Flange with Base Engine
- 4 Engine Timing Case Cover

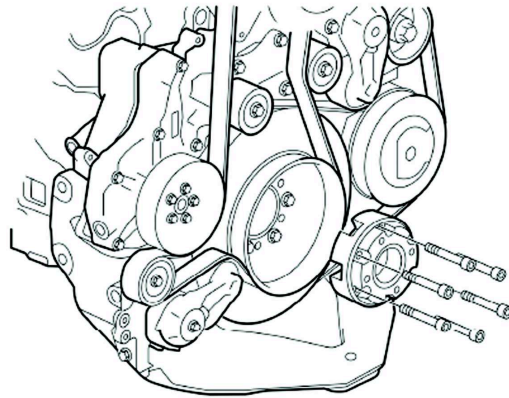

W9118577

Fig. 5 Crankshaft Vibration Damper

- Step 1 ..... 35 ± 5 Nm (26 ± 4 ft-lb)
- Step 2 ..... 90 ± 10 Nm (66 ± 7 ft-lb)

Bolt part number 959265, quantity 6 each

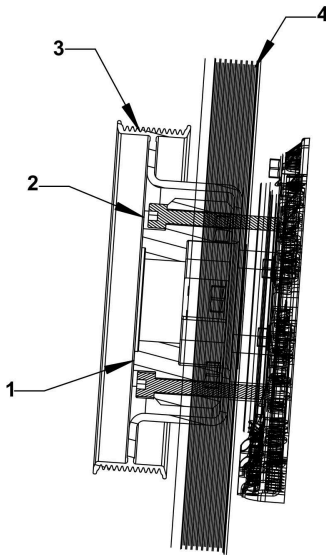

W4111399

Fig. 6 Exploded View, Front PTO Drive Adaptation, With 1240 Sq. in. Radiator

- 1 PTO Shaft Flange Mounting Surface
- 2 Adapter PTO Drive Coupling
- 3 Fan Drive Pulley
- 4 Crankshaft Damper

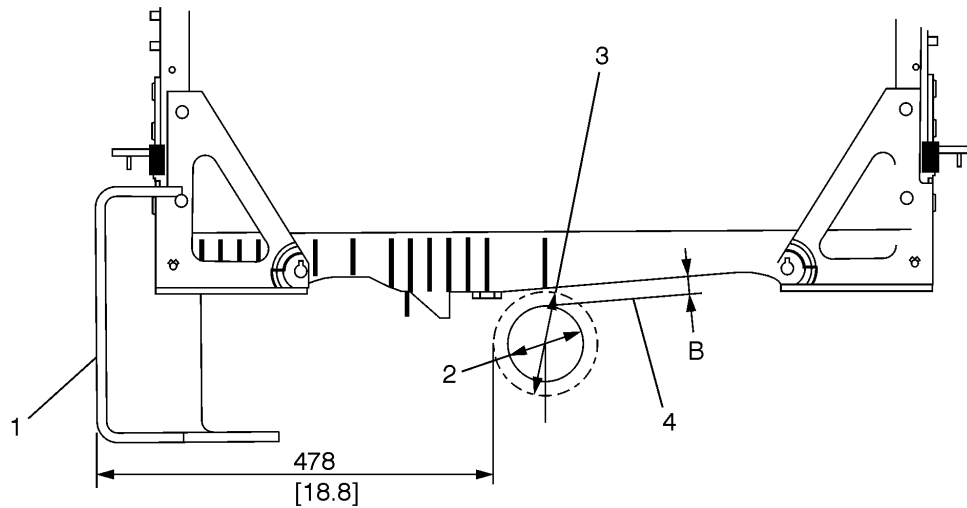

W4002365

Fig. 7 Partial Front View, With 930 Sq. in. Radiator (VHD Only)

- 1 RH Siderail
- 2 Tube diameter: 89 mm (3.5 in.)
- 3 Swing diameter: 1410 Series joint, 124 mm (4.9 in.)
- 4 Clearance to radiator with 1410 Series shaft tube in horizontal position.
- B Dimension (see table below)

Dimension	D13 mm (in.)
<b>B</b>	17 (0.7)

**Notes**

---



---



---



---



---

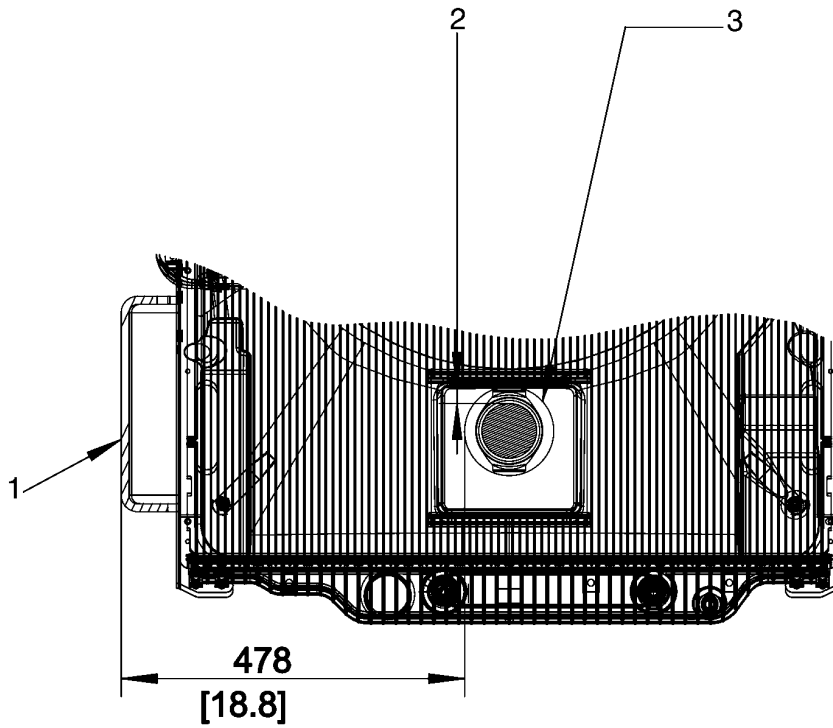

W4003030

Fig. 8 Partial Front View, With 1240 Sq. in. Radiator (VHD Only)

- 1 RH Siderail
- 2 76 mm Shaft Tube Clearance to Cooling Package
- 3 Swing diameter: 1410 Series joint, 124 mm (4.9 in.)

Engine	D11 / D13
Flange	SAE 1400 / 1100
Max output torque while stationary (vehicle speed < 3 mph)	600 ft-lb (813 Nm)
Max output torque while moving (vehicle speed > 3 mph)	284 ft-lb (385 Nm)

# Hydraulic Pumps

## Abbreviations

HPE = Hydraulic pump mounted to an engine power take-off (**H**ydraulic **P**ump **E**ngine mounted).  
HPG = Hydraulic pump mounted to a gearbox power take-off (**H**ydraulic **P**ump **G**earbox mounted).

## Pump Connection

There are two types of connections for hydraulic pumps:

- Din Drive pumps
- Flange mounted

## Din Drive Pumps

Plugged-in pumps are connected directly to the power take-off via a splined shaft. Connection is done according to DIN5462/ISO 7653 standard 8 X 32 X 36 mm spline shaft.

The VP1- and F1 Plus pumps are available for plugged-in mounting.

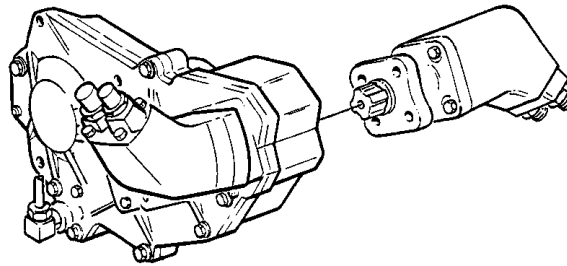

T4006560

Din mount

## Flange Mounted Pumps

The hydraulic pumps can also be connected to the power take-off via a propeller shaft. Connection is done to a flange according to SAE 1300 or SAE 1400 standard.

The VP1- and F1 Plus pumps are possible to connect to a propeller shaft.

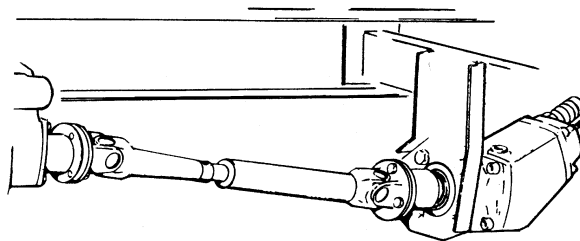

T9006112

Flange mounted

# Hydraulic System and Pumps

## Dimensioning of Hydraulic System and Hydraulic Pumps

**Note:** The body builder should enclose an information binder, delivered with the truck, including **hydraulic system data** (system dimensioning description and dimensioning criteria). Service, function and safety descriptions should also be enclosed.

It is the sole responsibility of the hydraulic system installer to follow all pump manufacturers guidelines for hydraulic system installation.

Volvo Trucks only supplies the information below as a guideline from the pump manufacturer and is not responsible for any mis-information in this section.

## Pipes, Lines and Hoses



### DANGER

Hoses and pipes should not be routed too near the warm points in the truck. Avoid crossed pipes which could cause chafing. Failure to follow this guide line increases the risk of fire if leakage occurs, and allows undue heat transfer to the hydraulic oil.

Connected to the hydraulic pump are a high-pressure hose, supply and drain lines.

*When dimensioning the hydraulic system, it is important that:*

- Hoses and lines must be connected to the pump with unions. O-ring seals must be used between pump and union.
- Tapered fittings should be avoided.
- Teflon tape or similar must not be used since pieces can break off and get into the hydraulic system and eventually cause damage.
- If steel piping is used, it must be installed so that movements and vibrations do not cause leakage. Normally hoses must be used nearest the pump.
- Oxide scale must be removed from pipes which have been heat-bent or welded. Flush or blow the pipes clean before installing them.

## High-Pressure Hose

These hoses must have a minimum of four steel wire coil inserts in order to withstand the high pressure in the hydraulic system.

*When mounting a high-pressure hose:*

- Make sure the hoses are not twisted when connected up.
- Make sure the hoses are long enough.
- Strive to get as few bends as possible on a hose.
- Avoid kinks by using correct unions. Only pressed unions may be used when replacing hose unions.

**Note:** Check for oil leakage and for high noise levels in the system when the truck is in motion.

## Supply Line

The supply line is made of piping or armored hose which retains its shape even when there is vacuum in the line.

*To avoid cavitation:*

- The supply line should be as short as possible and **should not exceed 4 meters (13.12 ft.)**. In the event longer lines are required, larger line dimensions must be used.
- The supply line should connect to the bottom of the tank and must be correctly tightened to prevent air getting into the oil.
- The supply line must have a wide diameter and must be free from kinks and constrictions. Do not use reducer fittings with restrictions.

**Note:** Avoid supply lines of high-pressure hooks and hooks made locally from pipe pieces welded together. They could cause unnecessary supply resistance.

*Suitable supply line sizes at different flow quantities and with a flow speed of less than 0,8 m/s:*

Inner diameter Ø mm (inches)	Flow up to liter/minute (gallons/minute)
50 (2.0)	0–120 (0–32)
64 (2.5)	101–150 (27–40)
75 (3.0)	> 150 (40)

## Drain Line and Bypass Valve

If the hydraulic pump is installed to a constantly running PTO (i.e. — engine PTO), it is provided with a bypass valve.

The bypass valve reduces the oil flow through the pump to obtain proper lubrication, low heat generation and to avoid cavitation.

### *Fixed Displacement Pump*

#### **HPE-FXX (F1 single flow)**

In order to prevent heat build-up in the pump during transportation, it is important that at least 5 liter/minute (1.32 gallons/minute) comes out of the filter at “q” (refer to the schematic below). This applies to an “open center” system when the valve is in the bypass mode (non-activated solenoid).

**Note:** If the flow at “q” is less than 5 liter/minute (5.28 quarts/minute) (caused e.g. by a high pressure drop in the main system) when the valve is in the bypass mode or if the hydraulic system is of the “closed center” type, then an external drain line **must be installed** from the bypass valve drain port directly to the hydraulic tank.

#### **HPE-TXX (F2 twin flow)**

In order to secure a cooling flow through the system, a separate drain line is already connected to the bypass valve from factory and the other end of the hose is temporary plugged. At final assembly the hose should be connected to the hydraulic tank, entering below oil level (preferable to the filter housing on the oil tank).

## Bypass Valve

For the fixed displacement hydraulic pumps, the bypass valve is attached directly on top of the end cap of the hydraulic pump. It is electrical operated and the valve function must only be activated or released at no-load (below 20 bar) system pressure.

For F2- twin flow hydraulic pump it can be used when, temporarily, one of the two circuits is not required; the power loss is thus reduced as the non-required flow is not forced through lines and “open center” valves.

- 1 Pilot operated check valve
- 2 Solenoid valve
- 3 Directional control valve (“open center”)
- 4 Hydraulic pump
- 5 Valve block
- 6 Drain port
- 7 (External line)

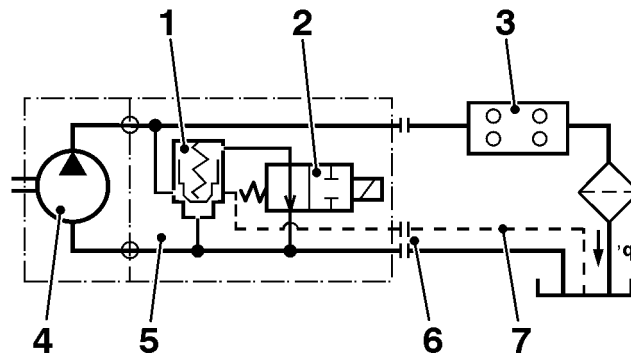

T9008080

HPE-FXX

## Notes

---

---

---

---

---

---

## Variable Displacement Pump

### HPE-VXX (VP1)

At final assembly, since the control valve on the hydraulic pump is not internally drained, there must be an external drain line installed between port "T" and the hydraulic tank.

### Bypass Valve

For variable displacement pump the bypass is, from factory, attached to the temporary oil reservoir and connected to the hydraulic pump via a hose to the port for gauge outlet, (on VP1-45 and VP1-75 port beside supply port and on the VP1-120 port "M" on the control valve).

The valve, which requires no additional control valve, allows the pump to operate on- or off-load up to its maximum self-priming speed.

When a load sensing valve function is engaged, the bypass flow is cut off (as port 'X' is being pressurized).

- 1 Hydraulic pump
- 2 Nipple with orifice
- 3 Bypass valve
- 4 Load sensing valve
- 5 Load sensing (LS) signal

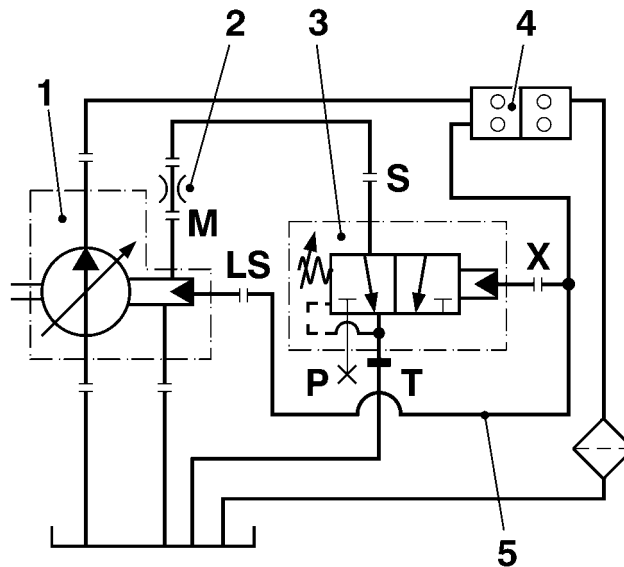

W4003014

HPE-V120

# Hydraulic Oil Tank

The tank must be large enough to avoid cavitation and overheating. A suitable volume is 1,5 times the nominal pump flow per minute.

*The tank includes:*

- 1 Air filter, fitted (as required) in a tube and provided with a non-return valve
- 2 Level gauge
- 3 Supply connector equipped with full-flow tap
- 4 Angled, perforated plate on which air bubbles accumulate and rise to the surface
- 5 Return oil filter

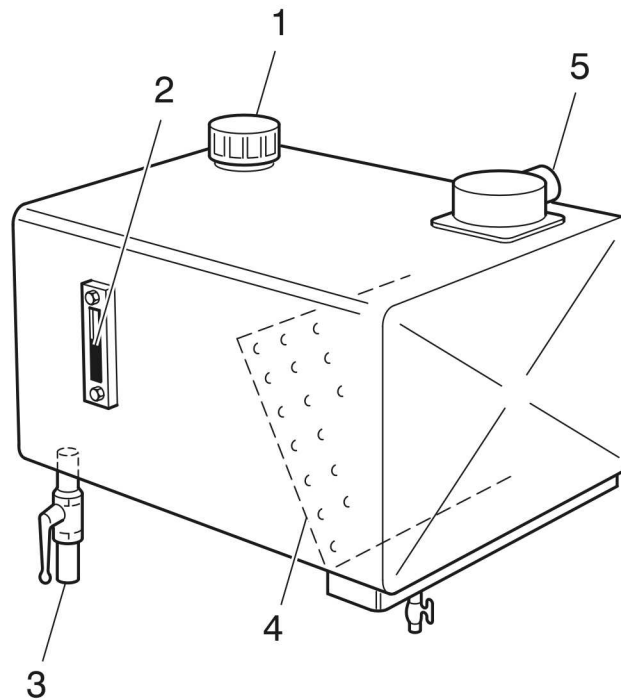

T9008314

Illustration is for reference only. May differ on specific vehicle.

When installing a hydraulic tank:

- The volume of the hydraulic tank must be dimensioned 1,5 times the nominal pump flow during normal working conditions.
- Make sure that the placing of the hydraulic tank does not limit the performance of the hydraulic pump.

*For example:* The supply fitting must not be placed below the inlet of the return pipe.



## WARNING

Hydraulic fluid level should be above the supply port of the pump or pump failure will occur.

- It is important that the deaeration surface is big enough. Prevent external dust and dirt from entering the hydraulic system. The inside of the tank must be well cleaned. To prevent dust getting into the system, the air filter should have the same filtration degree as the return oil filter.
- Oil is topped-up through the return oil filter, preferably via a rapid joint on the return line where the oil can be pumped in.
- Check oil level and ensure that it is oil of recommended type and viscosity.

## Return Oil Filter

**Note:** The filter must be replaced at least once a year.

A return oil filter should be installed in the tank or in the return line. The filter should be dimensioned for a capacity which is approximately twice that of the pump flow.

*Recommended filtration level:*

- A 28 micron filter should be used with lower pressures of 0–200 bar (0–2900 psi).
- A 10 micron filter should be used with higher pressures of 200–300 bar (2900–4351 psi).

Check return pipe and filter condition and check for oil leakage.

## Hydraulic Oil

**Note:** Do not mix oils of different quality.

Hydraulic fluids type HLP (DIN51524), automatic transmission fluid (ATF) Dextron II and engine oil type API/CD can be used.

*Recommended viscosity:*

- 20-30 mm<sup>2</sup>/s (.78–1.18 inches<sup>2</sup>/s) (cSt) .

## Starting Up



### CAUTION

Make sure the supply connector always is below the minimum level of the hydraulic oil. Failure to do so may result in component damage.

Make sure the entire hydraulic system is clean before filling it with a recommended fluid. In particular the pump, which must be purged to remove any entrapped air in the pump housing (use the uppermost purge port). Failure to do so may result in component damage.

## Notes

---

---

---

---

---

# Calculation of Hydraulic Pump Size

The following information is required to dimension the hydraulic system:

- Oil flow  $Q=l/min$  (Quarts/min.), to the equipment
- Oil pressure  $p=bar$  (psi), to do the work intended
- Permissible torque or power taken from the engine
- Permissible pump speed
- PTO Gear ratio

Control the pump environment with the **Parker** calculation program.

Go to **Introduction** on the VBI homepage, choose **Software requirement** and click on **Parker**.

## Engine Speed

### Engine Speed Control

Check that the permissible speed, specified by the pump manufacturer on the pump, is not exceeded.

Pump speed per minute  $n$  is governed by engine speed  $ne$  and power take-off gear ratio  $Z$ :

$$n = ne \times Z$$

$n$  = Pump speed (rpm)

$ne$  = Engine speed (rpm)

$Z$  = Power take-off gear ratio

## Pump Speed

The maximum (self-supply) speeds given in the catalogue apply at 1.0 bar (14.5 psi) (abs.) intake pressure.

To achieve correct pump speed the following is required:

- Oil level approx. 0.5 m above pump inlet
- Correctly dimensioned supply pipe
- Original supply nipple
- Correctly designed hydraulic fluid reservoir

The flow speed in the supply pipes should be less than **1 m/s (39.36 in/hg)**. Poor supply conditions lead to cavitation, high noise levels, shorter operational lifetime and, in the worst case, pump failure.

## Pump Capacity

The pump capacity or size **D** cm<sup>3</sup>/rotation (inches<sup>3</sup>/rotation) should be able to give sufficient oil flow **Q** l/min (inches<sup>3</sup>/min.) for the equipment. The choice of size depends on the oil flow required, engine speed and power take-off gearing. A small pump can give a large oil flow if the power take-off gear ratio is large, or if the engine speed is high.

Pump size is calculated as:

$$Q = \frac{D \times n \times \eta_v}{1000} \Leftrightarrow D = \frac{Q \times 1000}{n \times \eta_v}$$

**n** = Pump speed (ne x Z)

**D** = Pump size cm<sup>3</sup>/rotation (inches<sup>3</sup>/rotation)

**ne** = Engine speed

**Q** = Oil flow l/min (quarts/min.)

**Z** = Power take-off gear ratio

**$\eta_v$**  = volumetric efficiency

## Torque Control

A certain torque, **M<sub>ku</sub>** is required from the power take-off at the pump shaft to drive the pump. This torque must not exceed the permissible torque for the power take-off. Expressed in Nm, this torque is:

$$M_{ku} = \frac{D \times p}{63 \times \eta_{hm}} < M_{ku, till.}$$

**M<sub>ku</sub>** = Torque at power take-off (Nm)

**D** = Pump size cm<sup>3</sup>/rotation (inches<sup>3</sup>/rotation)

**p** = Hydraulic working pressure bar (psi)

**M<sub>ku, till.</sub>** = Permissible torque for the power take-off Nm (ft-lb)

**$\eta_{hm}$**  = Mechanical efficiency

< = Less than

## Torque Control, Engine

Torque control of the engine **M<sub>mot</sub>** must not exceed the permissible torque for the engine (please refer to Body builder instructions "Power take-off, performance") at a given engine speed.

Engine torque is equal to power take-off torque x gear ratio.

$$M_{mot} = M_{ku} \times Z < M_{mot, till.}$$

**M<sub>mot</sub>** = Engine torque Nm (ft-lb)

**Z** = Power take-off gear ratio

**M<sub>ku</sub>** = Torque at power take-off Nm (ft-lb)

**M<sub>mot, till.</sub>** = Permissible engine torque Nm (ft-lb)

< = Less than

## Power Requirements

The power **N** needed to drive the pump is proportional to the flow and working pressure and inversely proportional to the efficiency of the pump  $\eta$ .

Check that pump power curve, to see that it has the capacity needed to provide the calculated power **N**.

$$N = \frac{Q \times p}{600 \times \eta_t}$$

**N** = Power kW (hp)

**Q** = Flow through pump l/min (quarts/min.)

**p** = Working pressure bar (psi)

**$\eta_t$**  = Overall pump efficiency (**app. 0.95**)

$$\eta_t = \eta_v \times \eta_h m.$$

## Notes

---

---

---

---

---

---

## Example 1 (Dump), Selecting Pump Size Clutch Dependent PTO

### Operating conditions

Flow	60-80 l/min (63–85 quarts/min.)
Pressure:	230 bar (3335 psi)
Engine rpm:	800 rpm
PTO ratio:	1:1.53

### Determine the Pump Speed

$$n = n_e \times Z = 800 \times 1.53 = 1200 \text{ rpm}$$

### Choosing the pump size

$$Q = \frac{D \times n \times \eta_v}{1000} \quad D = \frac{Q \times 1000}{n \times \eta_v} \quad \frac{70 \times 1000}{1200 \times 0,98} = 60 \text{ cm}^3/\text{rotation}$$

Select F1-61 and check torque and power.

### Torque Requirement of the Pump

$$M_{ku} = \frac{D \times p}{63 \times \eta_{hm}} = \frac{59,5 \times 230}{63 \times 0,98} = 222 \text{ Nm}$$

### Power Requirement of the Pump

$$N = \frac{Q \times p}{600 \times \eta_t} = \frac{70 \times 230}{600 \times 0,95} = 28 \text{ kW}$$

### Notes

---

---

---

---

---

---

## Example 2 (General Crane), Selecting Pump Size Clutch Independent PTO

### Operating conditions

Flow	80 l/min (84 quarts/min.)
Pressure:	250 bar (3626 psi)
Engine rpm:	800 - 900 rpm
PTO ratio:	1:0.97

### Determine the Pump Speed

$$n = n_e \times Z = 800 \times 0,97 = 800 \text{ rpm}$$

### Choosing the Pump Size

$$Q = \frac{D \times n \times \eta_v}{1000} \quad D = \frac{Q \times 1000}{n \times \eta_v} \quad \frac{80 \times 1000}{800 \times 0,98} = 102 \text{ cm}^3 / \text{rotation}$$

Select F1-101 and check torque and power.

### Torque Requirement of the Pump

$$M = \frac{D \times p}{63 \times \eta_{hm}} = \frac{102,9 \times 250}{63 \times 0,98} = 417 \text{ Nm}$$

### Power Requirement of the Pump

$$N = \frac{Q \times p}{600 \times \eta_t} = \frac{102 \times 250}{600 \times 0,95} = 45 \text{ kW}$$

### Notes

---



---



---



---



---

# Pump Types

The following pump types are available from VOLVO:

- Pumps with fixed displacement
- Pumps with variable displacement

## Fixed Displacement Pump

This type of hydraulic pump is adapted for a single circuit system with fixed volume.

The fixed displacement pump consists internally of one or two single circuit(s), from the supply port to the pressure port(s).

Examples:

- HPE / HPG-F61 (Parker F1-61)
- HPE / HPG-F81 (Parker F1-81)
- HPE / HPG-F101 (Parker F1-101)
- HPE-T53 (Parker F2-53/53)
- HPE-T42 (Parker F2-42/42)

## Variable Displacement Pump

This type of hydraulic pump is also adapted for a single circuit system, from the supply port to the pressure port, but with variable displacement. When installed in a load sensing system, the variable displacement pump (VP1) supplies the correct amount of flow required by the various work functions currently engaged. This means that the energy consumption and heat generated are minimized and much reduced in comparison with a fixed displacement pump used in the same system.

Examples:

- HPE / HPG-V120 (Parker VP1-120)

## Notes

---

---

---

---

---

---

# Delivery Conditions for Factory Installed Hydraulic Pumps

 **CAUTION**

Hydraulic pumps must never be in use without oil flow in the hydraulic system. Failure to do so may result in component damage.

## For Trucks with Transmission Mounted PTO:

To prevent the possibility to engage the hydraulic pump before definitive assembly, the following is done from factory:

- The PTO magnetic valve outlet is blocked up by a hexagon socket plug.  
One or two valves is plugged, depending on type of PTO.
- The valve nipple, which the body builder should connect, is placed in a plastic bag and strapped on the end of the pneumatic hose at magnetic valve

## For Trucks with Engine Mounted PTO:

The hydraulic pump is always engaged; therefore sufficient lubrication is needed continuously for the pump.

- To establish lubrication during transport from factory to final assembly at body builder, **a temporary hydraulic transport kit** is added at the factory.
- The components in the kit (tank, hoses and unions) should be replaced; **they are not dimensioned for the working pressure** in the definitive hydraulic system.

**Note:** The replacement must be performed in particularly clean conditions. Dirt and other contamination which finds its way into the hydraulic system could easily cause severe damage.

### Temporary hydraulic transport kit

There are two different temporary kits, and the size of the oil reservoir differs:

1. Temporary hydraulic transport kit (for fixed displacement pumps)

Engine	Amount of oil if refill is needed
D11/D13 (HPE-FXX)	0.3 ± 0.05 liter (0.32 ± 0.05 quarts)

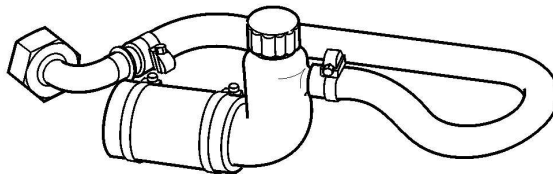

T9008337

2. Temporary hydraulic transport kit (for variable displacement or customer adaptation installed hydraulic pump)

Engine	Amount of oil if refill is needed
D11/D13	Minimum level on reservoir should be achieved after the engine is started. Approximately 10 liter (10.5 quarts).

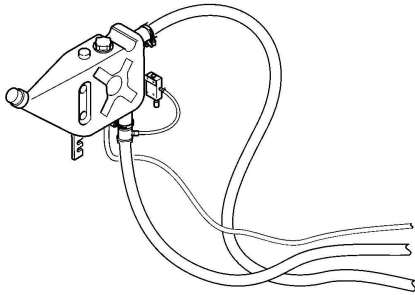

T9008338

D11 Engine

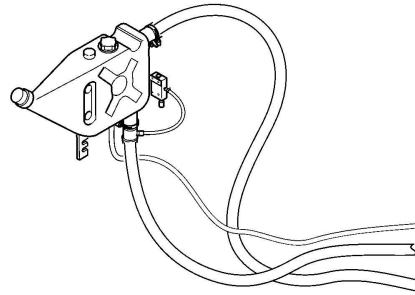

T9008338

With Engine Mounted PTO (D11 and D13)

## Connections to the Engine Mounted Hydraulic Pump

**A Factory delivered** Factory installed connection from the hydraulic pump. Dimension 25S (M36 x 2).

**B Body builder** Body builder's connection. Hose connection with 24° cone.

**C Supply side** Smallest external connection diameter see table below:

Hydraulic pump	Diameter X mm (inches)
HPE-V45 HPE-V75	50 (1.97)
HPE-FXX HPE-TXX HPG-FXX	63 (2.48)
HPE-V120 HPG-V120	75 (2.95)

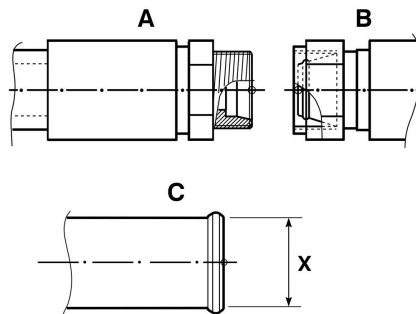

T9008408

X = smallest external connection diameter.

# Installation Requirements for Hydraulic Pump at Final Assembly



## CAUTION

Hydraulic pumps must never be in use without oil flow in the hydraulic system. Failure to do so may result in component damage.

### *Fixed displacement pump, HPE-FXX (F1 single flow)*

- Remove the temporary oil reservoir kit, tank, fittings and hoses are not designed for use in high pressure installations.
- See that enough oil flow (minimum 5l/min) is running in the final hydraulic system back to the hydraulic tank when the hydraulic pump is running unloaded. If not, a drain line must be installed from bypass valve to hydraulic tank entering below oil surface (to avoid "foaming" the oil).

### *Fixed displacement pump, HPE-TXX (F2 twin flow)*

- Remove the temporary oil reservoir kit, tank, fittings and hoses are not designed for use in high pressure installations.
- The drain hose from bypass valve, supplied loose from factory, must be connected to hydraulic tank entering below oil surface (to avoid "foaming" the oil). Dimension of hose fitting is M12x1,5 DIN 20078N. It is allowable to shorten the drain hose, but a new fitting must be attached in a proper way.

### *Variable displacement pump, HPE-VXX (VP1)*

- Remove the temporary oil reservoir kit, tank, fittings and hoses are not designed for use in high pressure installations.
- The bypass valve attached to the tank together with the hose between pump and by pass valve shall be kept and a drain hose should be connected between port "T" and hydraulic tank. It is allowable to shorten the drain hose between pump and bypass valve but a new fitting (M12x1,5 DIN 20078N) must be attached to fit onto fitting in bypass valve.
- The load signal on its way to port "LS" at the load sensing regulator on the hydraulic pump shall be connected in port "X" on the bypass valve as well.
- A drain line must be installed between port "T" on the hydraulic pump and the hydraulic tank since the load sensing regulator is not internally drained.

## Permissible Pump Bending Torque

The hydraulic pump mounted to a power take-off causes bending torque at the power take-off.

A transmission mounted power take-off has the following maximum permissible torque:

## PTR / PTRD with AMT-D and AMT-F Transmission

PTO	Maximum bending torque ft-lb (Nm)
PTR / PTRD	30 (40)

## Calculation of Pump Bending Torque

Torque is calculated with the formula below:

$$M_b = m \times g \times A$$

$M_b$  Bending moment at pump connection to power take-off (Nm).

$m$  Pump weight (kg).

$g$  Normal acceleration = 9.81 N/kg.

$A$  Distance between pump center of gravity and anchorage on power take-off (m).

**Note:** This calculation method is used irrespective of PTO/pump location.

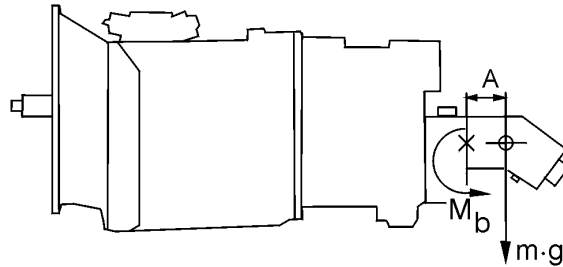

T9007591

# Propeller Shaft Installation

If a power take-off with coupling flange is to be used, the pump is installed by means of a bracket, either on an existing cross-member or on the sub-frame. An alternative method is to install an extra crossmember and install the pump on it. In this case, it is important to design the crossmember so that it can withstand the forces involved when the chassis twists and bends. The best way to achieve this is to design the crossmember as a normal, intermediate crossmember.

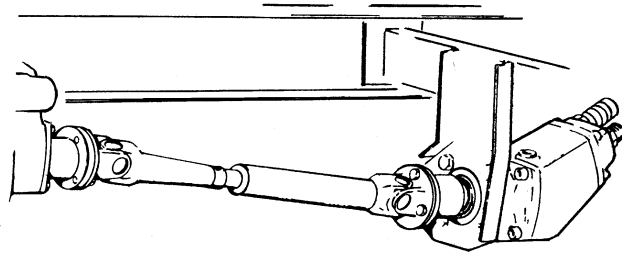

T9006112

The same requirements apply to power take-off propeller shafts as for drive line propeller shafts. For best service life, the true joint angle should be kept between 0.5 – 8 degrees.

It is important that angles  $\beta 1$  and  $\beta 2$  are equal.

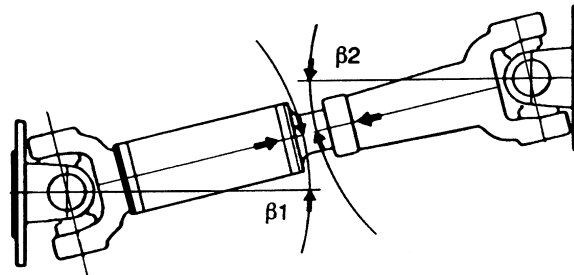

T9006113

## Notes

---

---

---

---

---

---

# Specifying the Pump

The PTO and the hydraulic pump must be selected to function properly in the application(s) for which the truck is intended. For example, a refrigeration unit must continue to operate while the vehicle is mobile, and the dump body must continue to operate while the vehicle is stationary. The PTO and pump also must have sufficient flow — dependent on oil flow, pressure, and the efficiency of the pump — to perform the designated work. The pump must be specified to achieve the flow of hydraulic oil required to ensure satisfactory operation of the equipment.

## Input Data

The equipment driven by the hydraulic system requires a certain oil flow and working pressure. The components driving the hydraulic system must not be overloaded.

Several variables affect specification of the correct PTO/pump combination for the hydraulic system. Typically, this information can be found on the *hydraulic equipment manufacturer's* data sheet. Equipment power requirements can include:

- Oil flow (Q) in LPM (GPM).
- Oil pressure (p) in bar (psi).
- Permitted torque/power output of the PTO.
- Permitted speed of the pump.
- Truck operating speed (spreading).

### Calculating pump displacement cc/rev (in<sup>3</sup>/rev)

$$D = \frac{Q \times 231}{N_e \times Z} \quad \text{or} \quad \frac{D \times N_e \times Z}{231}$$

### Calculating PTO/pump torque Nm (ft-lb)

$$T = \frac{D \times p}{74}$$

### Calculating PTO/pump power kW (hp)

$$P = \frac{Q \times p}{1680 \times \eta}$$

### Checking maximum PTO/pump speed (rpm)

$$N_p = N_e \times Z \quad \text{or} \quad N_e = \frac{N_p}{Z}$$

Q	=	Flow	LPM (gpm)
Ne	=	Engine speed	(rpm)
Np	=	Pump speed	(rpm)
Z	=	PTO ratio	(0.60, 0.73, 0.91, 1.23, 1.30, 1.54, 1.62)
D	=	Dump displacement	cc/rev (in <sup>3</sup> /rev)
p	=	Working pressure	bar (psi)
P	=	Power	hp (kW)
T	=	Torque	ft-lb (Nm)
μ	=	Efficiency	0.75 - 0.85 Gear Pump 0.90 - 0.95 Piston Pump

### *Pump Capacity, Displacement*

The pump capacity or size (D = cc/rev (in<sup>3</sup>/rev)) must be able to offer sufficient flow (Q = LPM (GPM)) for the proper operation of the equipment. The selection of the pump size depends on the desired flow, engine speed, and PTO ratio. A small pump can allow a large flow if the PTO ratio or engine speed is high enough.

Use the following to calculate pump size:

**D** Pump Size cc/rev (in<sup>3</sup>/rev)

**Q** Flow LPM (GPM)

**Ne** Engine Speed (rpm)

**Z** PTO Ratio

$$D = \frac{Q \times 231}{Ne \times Z} \quad \text{or} \quad Q = \frac{D \times Ne \times Z}{231}$$

## RECOMMENDATION

Select the highest possible PTO ratio and the smallest pump size that meet the requirements without exceeding the pump speed, pressure, and power limits.

## PTO/Pump Power Requirements

The engine must provide sufficient power to drive the pump.

The power (P) required to drive the pump is in direct proportion to the flow and working pressure, and is in inverse proportion to the pump efficiency (n).

Use the following to calculate the engine power requirement:

- P** Power kW (hp)
- Q** Flow Through the Pump LPM (GPM)
- p** Working Pressure
- n** Pump efficiency

$$P = \frac{Q \times p}{1680 \times n}$$

### Engine Operating Speed Recommendation

PTO Power Requirement hp (kW)	Engine rpm (Ne)
< 40 (30)	700 - 800
42-67 (31 - 50)	800 - 900
68-94 (51 - 70)	900 - 1000
> 95 (71)	>1000

### Notes

---

---

---

---

---

---

## Checking PTO Torque

A certain torque is required from the PTO on the pump shaft to drive the pump. This torque should be less than that which is permitted on the PTO itself.

Use the following to calculate the PTO torque:

- T** Torque — Nm (ft-lb)
- D** Pump Size — cc/rev (in<sup>3</sup>/rev)
- P** Hydraulic System Pressure — bar (psi)
- Tperm** Permitted Torque on PTO (< Engine Torque)

**Note:** If only the engine power curve is available, check as described in “PTO/Pump Power Requirements”, page 74 .

$$P = \frac{Q \times p}{1680 \times n} < T_{perm}$$

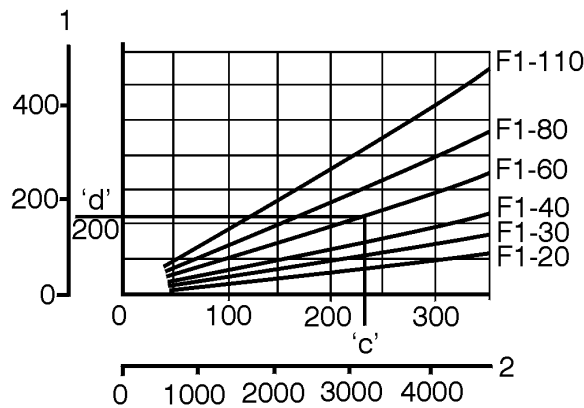

W4002390

Torque Curve, Parker/VOAC Pumps

## Notes

---



---



---



---



---

## Speed Check

Make sure that the permitted speed of the pump (as stated by the pump manufacturer) is not exceeded.

The pump speed ( $N_p$ ) is governed by the engine speed ( $N_e$ ) and the PTO ratio ( $Z$ ).

Use the following to calculate pump speed:

**$N_p$**  Pump Speed/Minute

**$N_e$**  Engine Speed (rpm)

**$Z$**  PTO Ratio (%)

Constant speed during driving is obtainable with a variable pump. The engine speed ( $N_e$ ) for a clutch-dependent PTO is often set to operate around 1000 rpm (engine). If the PTO is driven with an inappropriately low engine speed, an uneven flow can occur as the engine speed drops during loading.

$$N_p = N_e \times Z \quad \text{or} \quad N_e = \frac{N_p}{Z}$$

### Power Requirements vs. Engine Speed

PTO Power Requirement hp (kW)	Engine rpm ( $N_e$ )
< 40 (30)	700 - 800
42-67 (31 - 50)	800 - 900
68-94 (51 - 70)	900 - 1000
> 95 (71)	>1000

### Notes

---

---

---

---

---

---

# Supply and Pressure Lines

The size (diameter and length) of the supply/pressure lines also will affect the function of the hydraulic system (see “Hydraulic Line Requirements”, page 78 ).

The supply line should be of sufficient diameter and minimum length without restrictions (pipe adapters) between the pump and the oil reservoir connection. A pressure line with insufficient diameter will create unnecessary pressure losses in the form of heat. A flow of 11.5 LPM (30 GPM) with a pressure drop of 9.65 bar (140 psi) will generate approximately 1.7 kW (5800 BTU).

Use a calculation sheet to determine the correct PTO/pump combination (see “Calculating/Selecting a PTO and Matching Pump”, page 77 ).

## Calculating/Selecting a PTO and Matching Pump

Customer	_____		
Vehicle	_____		
Engine	_____		
Transmission	_____		
Equipment	_____		
1. Equipment flow demand	Q =	_____	lpm (gpm)
2. Working pressure	p =	_____	bar (psi)
3. PTO alternative ratio	Z =	_____, _____, _____	
4. Pump alternatives	D =	_____, _____, _____	
5. Engine working speed	Ne =	_____, _____, _____	rpm

### Pump displacement cc/rev (in<sup>3</sup>/rev)

$$D = \frac{Q \times 231}{Ne \times Z} \quad \text{or} \quad \frac{D \times Ne \times Z}{231}$$

### PTO/pump power kW (hp)

$$P = \frac{Q \times p}{1680 \times n}$$

### PTO/pump torque Nm (ft-lb)

$$T = \frac{D \times p}{74}$$

# Hydraulic Line Requirements

## Supply Pipe/Line

The figures in the table show the minimum inside diameter without restrictions (pipe adapters) of a supply pipe from the tank into the pump needed to avoid cavitation (noise). Other parts of the system can be designed differently, depending on installation requirements.

### Minimum Inside Diameter

VOAC F1 - Pump	Inside Diameter of Supply Pipe	
F1-61	38/50 mm	1.5/2.0 in.
F1-81/101	50/65 mm	2.0/2.5 in.



### CAUTION

A supply line with insufficient diameter will create cavitation damage and low pump efficiency.



### WARNING

Hydraulic fluid level should be above the supply port of the pump or pump failure will occur.

## Pipe/Line Selection

To prevent cavitation (noise) damage and excessive pressure losses (heat), the inside diameter of the pipe must be the correct size. Do not exceed the maximum flow speeds.

### Maximum Allowable Flow Speeds

Line Type	Pressure bar (psi)	Flow Speed m/s (ft/s)
Supply	—	0.45 – 1.07 (1.5 - 3.5)
Pressure	103 – 310 1500 - 4500)	3.05 – 4.88 (10 - 16)



### CAUTION

A pressure line with insufficient diameter will create unnecessary pressure losses which will appear as heat. A flow of 113.5 LPM (30 GPM) with a pressure drop of 9.65 bar (140 psi) will generate approximately 1.7 kW (5800 BTU), which can cause abnormal wear and damage to components.

Select the smallest inside line diameter that meets the flow speed recommendations.

**Recommended Inside Line Diameter**

Fluid Flow	Flow Speed m/s (ft/s) at Indicated Inside Line Diameter				
	LPM (gpm)	19.1 mm (0.75 in.)	25.4 mm (1.00 in.)	31.8 mm (1.25 in.)	38.1 mm (1.50 in.)
37.9 (10)	2.23 (7.3)	<b>1.25 (4.1)</b>	<b>0.79 (2.6)</b>	<b>0.55 (1.8)</b>	<b>0.3 (1.0)</b>
56.8 (15)	3.32 (10.9)	1.86 (6.1)	<b>1.19 (3.9)</b>	<b>0.82 (2.7)</b>	<b>0.46 (1.5)</b>
75.7 (20)	4.42 (14.5)	2.5 (8.2)	1.58 (5.2)	<b>2.0 (3.6)</b>	<b>0.61 (2.0)</b>
94.6 (25)	N/A	3.1 (10.2)	1.98 (6.5)	<b>1.37 (4.5)</b>	<b>0.79 (2.6)</b>
113.6 (30)	N/A	3.75 (12.3)	2.38 (7.8)	1.68 (5.5)	<b>0.91 (3.0)</b>

Pressure Pipe

Supply Pipe

**Oil Reservoir Tank**

As a guide, an oil reservoir tank with a capacity 1 or 2 times the pump flow/minute will be sufficient. For shorter periods of operation, a smaller capacity may be used.

Prior to installation, the oil reservoir must be cleaned to remove all manufacturing debris. The inside area should be treated with oil-resistant paint. Prior to filling the tank, the oil should be poured through a filter to eliminate any possibility of dirt entering the tank. An oil filter with a rating of 10 microns (absolute) should be installed in the tank or return line. Oil filters should be changed annually.

**RECOMMENDATION**

51 mm (2 in.) supply line should be used between pump and reservoir (with no reducer fitting); supply line restrictions should be minimized.

**RECOMMENDATION**

51 mm (2 in.) ball valve should be used as shut-off device whenever feasible.

**Notes**

---



---



---



---



---

# Hydraulic Piston Pumps

Volvo Trucks North America offers both single and twin-flow Parker hydraulic pumps, which can be driven in the following ways:

- Direct-driven pump – can be mounted directly on the PTO, either at the factory or by the body builder company, in accordance with the DIN 5462/ISO 7653 standard. All Parker F1 and F2 pumps can be direct mounted to either the transmission or engine PTO.
- Single driveshaft driven pump – can be driven by a driveshaft connected to the PTO SAE 1310/1410 flange and are typically mounted by the body builder company.

## F1 and F2

Pump Frame Size	25	41	61	81	101	42 A	42 B	53 A	53 B
Displacement (cu.in/rev)	1.56	2.50	3.63	4.98	6.28	2.62	2.50	3.29	3.17
Max Continuous Pressure	3,600	3,600	3,600	3,600	3,600	5,000		5,000	
Max Intermittent Pressure	5,000	5,000	5,000	5,000	5,000	5,800		5,800	
Min Speed RPM @ Max Pressure Max	2700	2700	2700	2300	2300	2,550		2,550	
	2200	2100	1900	1750	1550	1800		1800	
Continuous Max Output Horsepower Intermittent	26.8	36.2	45.5	54.9	64.3	117		147	
	34.8	49.6	59.0	72.3	83.1	134		168	
Weight (lbs)	18.7	18.7	18.7	27.5	27.5	41.8		41.8	



W9114241

The F1 and F2 are piston pumps that are larger in size than the GP1, piston pumps are more efficient than gear pumps and therefore produce less heat during the operation.

Piston pumps are 97% efficient at ~1000 rpm.

# F1 pump features:

- Higher self-priming speeds
- Operating pressures to 400 bar
- Higher overall efficiency
- Increased reliability
- Reduced noise level
- Easier to change direction of rotation
- Optimized commutation - low flow pulsations
- Installation above the reservoir level possible
- Smaller installation dimensions

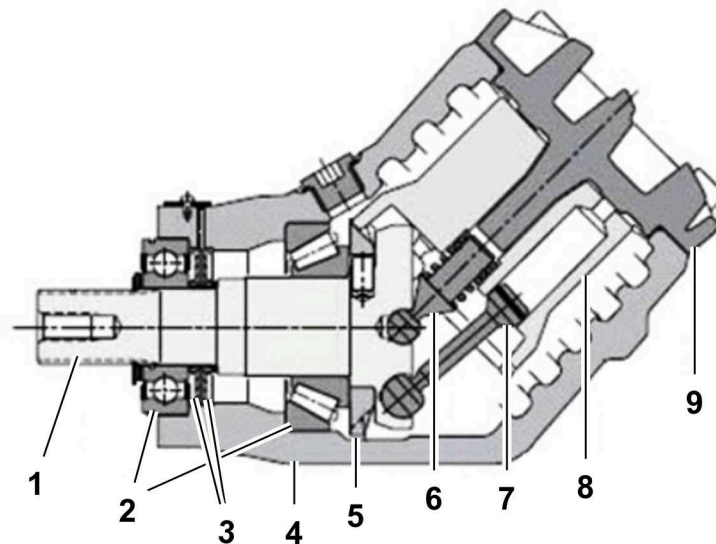

W9124202

1. Input shaft
2. Bearings
3. Shaft seals
4. Housing
5. Timing gear

6. Barrel support
7. Piston with piston ring
8. Cylinder barrel
9. End cap

# Pump rotation change RH to LH (applies to F1 series only)

Recommend holding pump in vise: Follow steps (a) through (e) below.

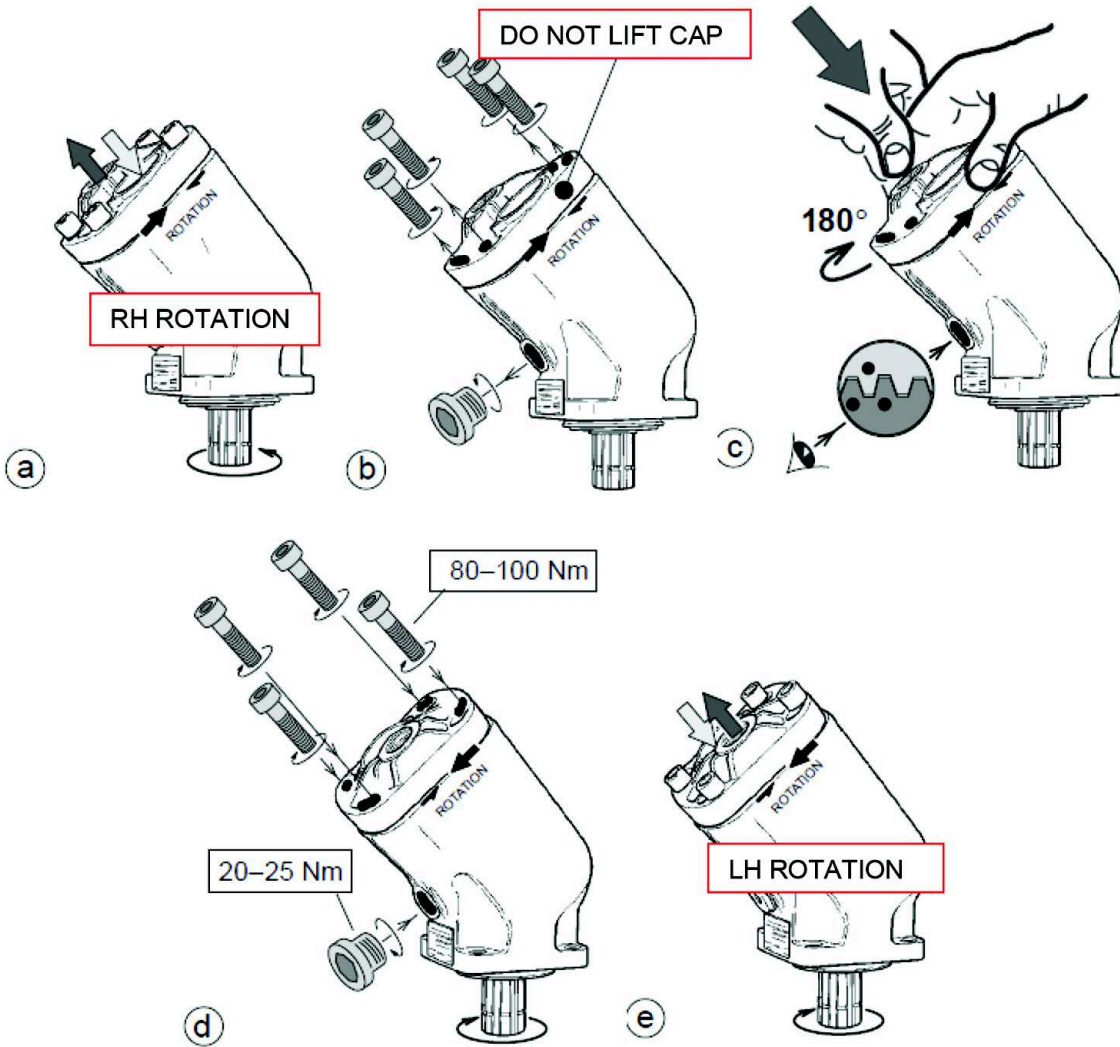

W9122747

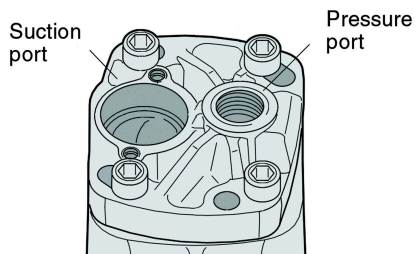

W9124467

**Left hand rotation**

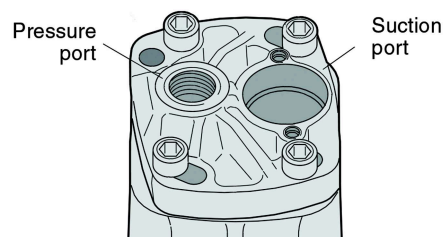

W9124468

**Right hand rotation**

# F2 pump features:

Series F2 is a further development of the twin-flow version of series F1, the very first bent-axis truck pump on the market to feature two entirely independent flows. With a suitable build-up of the hydraulic system, the main advantage with a twin-flow pump is that three different flows can be provided at the same engine speed. The twin-flow pump makes it possible to further optimize the hydraulic system and offers:

- Less energy consumption
- Reduced risk of system overheating
- Lower weight when compared to installation of two pumps
- Easier installation
- Standardized system solutions

The twin-flow pump makes it possible to operate two work functions that are independent of each other while allowing higher speed and an increased operating precision. Another requirement can be a large and a small flow, or two equal flows. All of these alternatives are possible with the twin-flow pump.

The pump can be utilized to provide one flow at high system pressure, and, as soon as the pressure has decreased sufficiently, add the flow from the other circuit. This eliminates the risk of exceeding the PTO power rating and, at the same time, provides an optimal driving function.

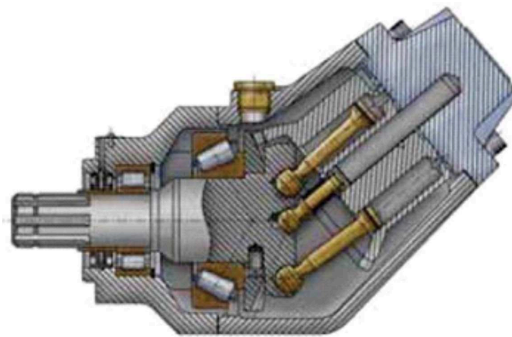

W9114243

## Notes

---

---

---

---

---

Parker provides charts to determine the most suitable pump for a PTO operation; the charts are in metric so a conversion to conventional US units is required.

1 bar = 14.503 psi

1 Liter = .26417 gallons

1 kW = 1.3404 hp

Pump Flow (gpm) at Pump Speed (rpm)							
Pump	1000 rpm	1200 rpm	1400 rpm	1600 rpm	1800 rpm	2000 rpm	2200 rpm
F1-25	6.8	8.1	9.4	10.8	12.2	13.5	14.9
F1-41	10.8	12.9	15.1	17.2	19.4	21.6	23.7
F1-61	15.7	18.9	22.0	25.1	28.3	31.4	34.6
F1-81	21.6	25.9	30.2	34.5	38.8	43.1	————
F1-101	27.0	32.4	37.8	43.2	48.5	————	————
F2-42/42	11.3/10.8	13.6/13.0	15.9/15.2	18.1/17.3	20.4/19.5	————	————
F2-53/53	14.3/13.7	17.1/16.5	20.0/19.2	22.9/22.0	25.6/24.7	————	————

\* Refer to the specific Product Information bulletins in TM2 for pump housing dimensions and performance.

**Note:** A new gasket is necessary, when installing a new pump. The gasket is available as part number 20551226.

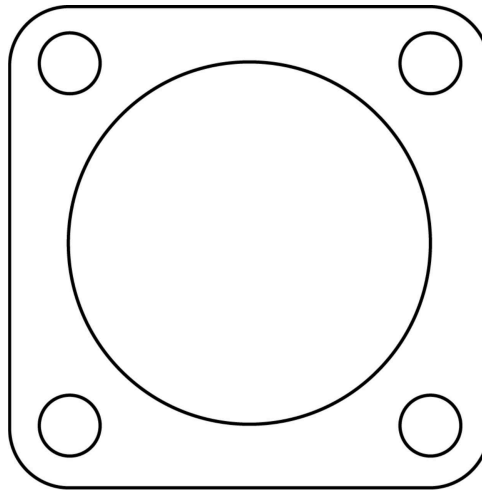

W9122748

# Pump Bearing Life

Bearing life is dependent on how the pump is installed on the PTO as shown in the illustrations below.

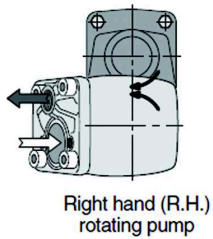
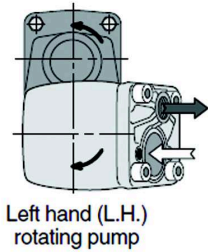

Fig. 1.

Bearing life is dependent on how the pump is installed on the PTO as shown in the illustrations below.

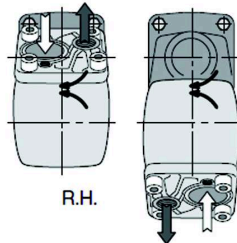
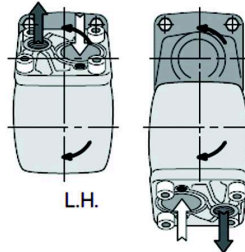
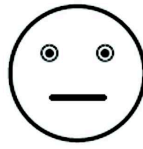

Fig. 2.

Parker Hannifin will assist in determining bearing life in a particular application.

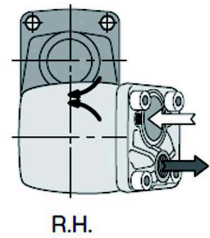
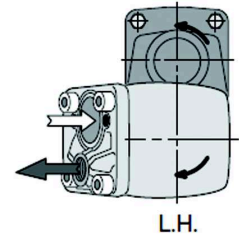
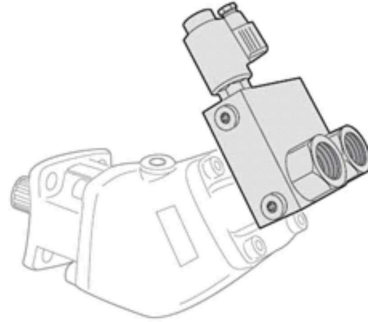

Fig. 3.

## BPV-F1 Bypass Valve

An F1 pump supplied with a bypass valve can be utilized in applications where the pump is operating constantly i.e. when the pump is driven from the crankshaft through a driveshaft or mounted directly to a DIN 5462 REPTO or it can be installed on a PTO. In most cases, the bypass valve allows the pump to be driven at max engine rpm during transportation at no load. This prevents pump cavitation and high heat generation which may otherwise be encountered at large flows. The BPV valve connects the outlet and inlet ports of the pump, and only a small oil flow goes through the system to the tank. The valve is installed directly on top of the pump port surface with 'banjo' fittings. As the BPV valve is symmetrical it can be 'turned 180°' to suit either left hand or right hand pump rotation, or to prevent interference with chassis components. The valve can only be engaged or disengaged (through a 12 VDC solenoid) at no-load system pressure.



W9114244

Bypass Valve			
Model	Pump Application	Parker Part No.	Volvo Part No.
BPV-F1-25	F1-25	3787712	21418975
BPV-F1-25	F1-41, F1-51, F1-61	3787047	21230082
BPV-F1-81	F1-81, F1-101	3787048	21230083
BPV-F2	F2-42, F2-53	3781774	20374479

## BPV-F1-25 and -81 Bypass Valve

The bypass valve is mainly utilized in applications where the F1 pump is driven from the crank-shaft through a driveshaft, or when it is installed on a REPTO. The BPV bypass valve should be engaged during transportation when the pump is operating constantly and the engine is running at max rpm; the hydraulic system is not sized for the large flow that would otherwise go through it. The BPV valve substantially reduces the energy loss during transportation. The valve installs directly on top of the pump end cap with a pressure port 'banjo' fitting and an inlet port spacer bushing with two cap screws; refer to the illustration below. As the BPV valve is symmetrical, it can be 'turned 180°' to prevent interference with chassis components; it can be utilized for either left hand or right hand pumps. The valve function must only be activated or released (by means of a 12V VDC solenoid) at no-load (below 290 psi) system pressure.

### Important Information

In order to prevent heat build-up in the pump during transportation, it is important that at least 1.3 gal/min comes out of the filter at 'q' (refer to the schematic). This applies to an "open center" system when the valve is in the bypass mode (non-activated solenoid).

**Note:** a) If the flow at 'q' is less than 1.3gal/min (caused e.g. by high pressure drop in the main system) when the valve is in the bypass mode.

b) If the hydraulic system is of the 'closed center' type, then an external drain line must be installed from the bypass valve drain port directly to tank as shown in the schematic; a drain kit is available.

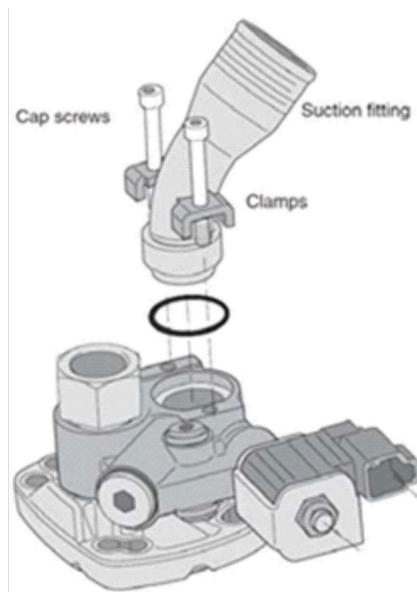

W9114245

# Hydraulic Wet Kits

Use of the Parker F1, F2, and GP1 pumps requires components that are not traditionally installed into NA truck hydraulic systems.

1) To modulate the flow of oil so that the operation of the hydraulic system can be regulated traditional systems use a control valve that is incorporated into the pump assembly. The Parker F1, F2, and GP1 require the addition of an oil flow regulator to be installed in the circuit remotely from the pump to control the flow of the oil from the pump to the system actuator.

2) Parker F1 and F2 pumps run very tight tolerances to achieve the 97% pump efficiency so the system requires that a filter element be installed into the return line to filter out debris as the oil returns to the tank. A pressure gauge is recommended to be installed in the filter housing to indicate when the filter element has trapped sufficient debris that it restricts the flow of oil back to the tank and requires the replacement of the filter.

## Installation and Start-up for F1 and F2 Hydraulic Pumps

**Fluids** — Need to operate with a high quality, mineral based hydraulic oil. Type HLP hydraulic oil is suitable, as well as biologically degradable fluids like natural and synthetic esters and polyalphaolefins.

- SS 15 54 34
- SMR Hydraulic Oil Standard 1996-2

\*Contact Parker Hannifin for further information.

**Start-up** — Make sure the entire hydraulic system is clean and the pump is filled (to at least 50%) with a recommended hydraulic fluid, as the internal leakage does not provide sufficient lubrication at start-up.

**Drain Line** — Fixed displacement pumps don't need an external drain line as they are internally drained. However, when the pump is mounted on an engine PTO, it is recommended to mount a drain line from the bypass valve directly to the oil tank if in doubt.

### Notes

---

---

---

---

---

---

# High Pressure Hose

These hoses must be designed to withstand the high pressure in the hydraulic system. When installing a high pressure hose:

- Make sure the hoses are not twisted when connected.
- Make sure the hoses are long enough.
- Strive to get as few bends as possible on a hose.
- Avoid kinks by using correct unions.

## Hydraulic Flow Pump, D11 Engine, (GPM) at Pump Speed (rpm) REPTO

Parker/VOAC Pump <sup>1</sup>	REPTO Ratio	Pump Speed (rpm)					
		800 L/min (gpm)	900 L/min (gpm)	1000 L/min (gpm)	1200 L/min (gpm)	1400 L/min (gpm)	1600 L/min (gpm)
F1-61	1:1.08	51 (13.5)	58 (15.3)	64 (16.9)	77 (20.3)	90 (23.8)	103 (27.2)
F1-81	1:1.08	71 (18.8)	79 (20.9)	88 (23.2)	106 (28.0)	123 (32.5)	141 (37.2)
F1-101	1:1.08	89 (23.5)	100 (26.4)	111 (29.3)	133 (35.1)	156 (41.2)	178 (47.0)
F2-42/42	1:1.08	37/35 (9.8/9.2)	42/40 (11.1/10.6)	46/44 (12.2/11.6)	56/53 (14.8/14.0)	65/62 (17.2/16.4)	74/71 (19.5/18.8)
F2-53/53	1:1.08	47/45 (12.4/11.9)	52/51 (13.7/13.5)	58/56 (15.3/14.8)	70/67 (18.5/17.7)	82/79 (21.6/20.9)	93/90 (24.6/23.8)

## Hydraulic Flow Pump, D11 and D13 Engines, (GPM) at Pump Speed (rpm) REPTO

Parker/VOAC Pump <sup>1</sup>	REPTO Ratio	Pump Speed (rpm)					
		800 L/min (gpm)	900 L/min (gpm)	1000 L/min (gpm)	1200 L/min (gpm)	1400 L/min (gpm)	1600 L/min (gpm)
F1-61	1:1.26	51 (13.5)	58 (15.3)	64 (16.9)	77 (20.3)	90 (23.8)	103 (27.2)
F1-81	1:1.26	71 (18.8)	79 (20.9)	88 (23.2)	106 (28.0)	123 (32.5)	141 (37.2)
F1-101	1:1.26	89 (23.5)	100 (26.4)	111 (29.3)	133 (35.1)	156 (41.2)	178 (47.0)
F2-42/42	1:1.26	37/35 (9.8/9.2)	42/40 (11.1/10.6)	46/44 (12.2/11.6)	56/53 (14.8/14.0)	65/62 (17.2/16.4)	74/71 (19.5/18.8)
F2-53/53	1:1.26	47/45 (12.4/11.9)	52/51 (13.7/13.5)	58/56 (15.3/14.8)	70/67 (18.5/17.7)	82/79 (21.6/20.9)	93/90 (24.6/23.8)

## Parker Hannifin Pressure Fittings

A special pressure fitting is required to convert the threads in the pump from BSPP to SAE J37. These fittings are available from Volvo Trucks under the following part numbers.

Volvo Part Number	Pump Size	BSPP Thread	Tube Size mm (in)
PHV-12F40MXS	F1-41, F1-51, F1-61 F2-52 / 52, F2-42 / 42 GP1-23, GP1-41	3/4 x 14	19 (3/4)
PHV-16F40MXS	F1-81, F1-101	1 x 11	25 (1)
PHV-1620F40MXS	GP1-60, GP1-80, GP1-100	1 1/4 x 11	25 (1)
PHV-20F40MXS	GP1-60, GP1-80, GP1-100	1 1/4 x 11	30, 32 (1 1/4)
PHV-24-20F40MXS	GP1-60, GP1-80, GP1-100	1 1/4 x 11	38 (1 1/2)

## Hydraulic Pumps Offered By Volvo



W9133804

Parker Gear Pumps		
Model	Parker Part No.	Volvo Part No.
GP1-23	3789383	22045713
GP1-41	3789384	22045714
GP1-60	3789385	22045715
GP1-80	3789386	22045716
GP1-100	3784184	22725227

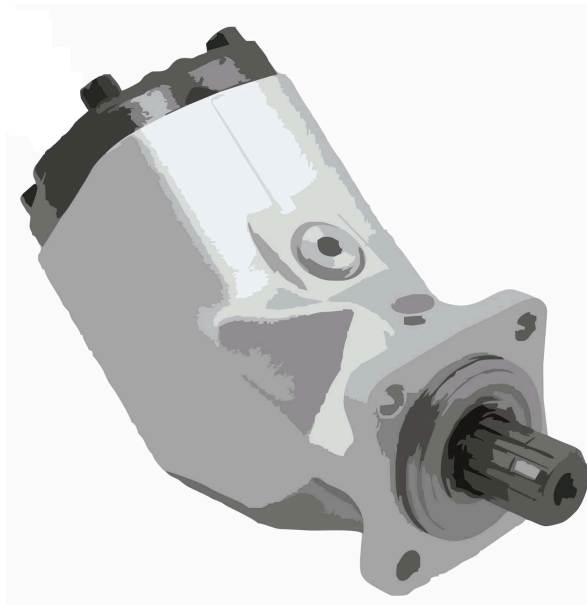

W9133805

Parker Bent Axial Piston Fixed Pumps		
Model	Parker Part No.	Volvo Part No.
F1-25	3781524	20455918
F1-41	3781540	20392941
F1-51	3781550	20392942
F1-61	3781560	20392943
F1-81	3781580	20392944
F1-101	3781600	20392945
F2-42 / 42	3785783	20909025
F2-53 / 53	3783573	20458341

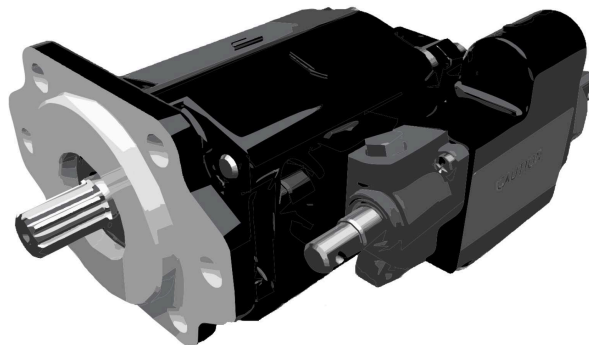

W9133806

Parker Dump Pump		
Model	Parker Part No.	Volvo Part No.
G102	3089310913	22745915

**Note:** Pump specifications can be found in the Pump Speed Calculator or at [www.parker.com](http://www.parker.com)

# Flow Pump, Exploded View

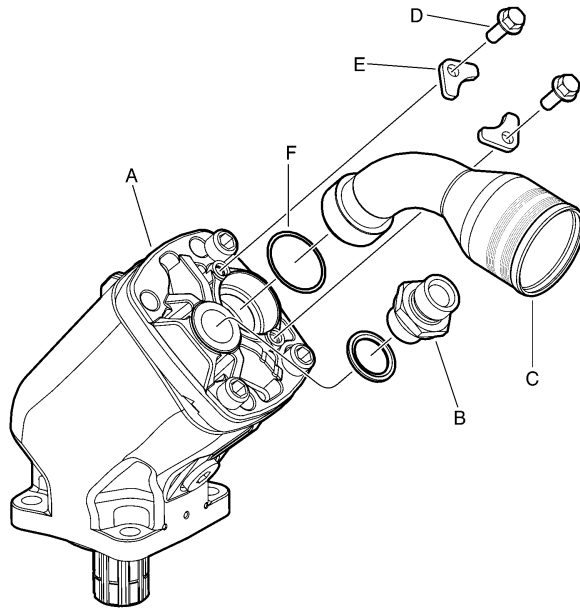

W4003046

Flow Pump, Exploded View	
A	Pump Assembly
B	Pressure Fitting
C	Supply Tube Kit
D	Screw, included in Supply Tube Kit
E	Clamp, included in Supply Tube Kit
F	O-ring, included in Supply Tube Kit

# PTO Fittings

Straight Fitting			
Part Numbers	A mm (in)	B mm (in)	C mm (in)
85100131	17 (0.6)	136 (5.4)	50 (2)

45 Fitting			
Part Numbers	A mm (in)	B mm (in)	C mm (in)
85100585	67 (2.6)	110 (4.3)	50 (2)

90 Fitting			
Part Numbers	A mm (in)	B mm (in)	C mm (in)
85114334	135 (5.3)	83 (3.3)	50 (2)
85114335	147 (5.8)	103 (4.1)	63 (2.5)

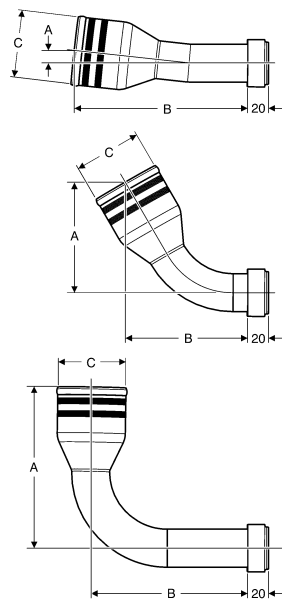

W4003045

Images from top to bottom:

- Straight Fitting
- 45° Fitting
- 90° Fitting

**Note:** All pumps have a right hand direction of rotation as seen from the PTO (looking to the front of the vehicle).

**Note:** All supply fittings come in kit form. Includes clamps, bolts, and O-ring.

# Volvo Body Builder Prep

There are two types of PTO engine speed control used in Volvo trucks:

**“Stalk” PTO** is standard equipment and is initiated and controlled using the cruise control "ON/OFF", "SET+", "SET-", and "RESUME" stalk switches.

- VECU reads the cruise control stalk switch states, and commands the engine into PTO mode when conditions are right.
- These conditions are programmable in the VECU and might include a maximum vehicle speed, park brake set or not, etc.
- The engine PTO 'set speed' is selected by either pressing the cruise control "RESUME" button, or by using the accelerator pedal to get the desired engine speed and pressing one of the cruise control "SET" buttons (either SET+ or SET-).
- Once the PTO function is active, the SET+ or SET- buttons can be used to adjust the PTO engine speed (within limits).

**“Remote” or “Wired” PTO** is most commonly associated with the engagement of an engine or transmission “Wired” PTO driven accessories, where the user wishes to “remotely” activate the engine speed control function.

- It is usually accomplished by wiring the auxiliary equipment to the PTO function controller (VECU, BBM ECU, or Engine ECU) so that engaging one will automatically activate the other.
- How each of these different PTO functions operates will depend upon the programmed parameters in the VECU and (if equipped) the BBM ECU.
- When only a VECU is present (no BBM ECU), the Volvo Engine is limited to one (1) remote or "wired" PTO function. This is referred to as "PTO1". The PTO1 function actually consists of two parts:
  - An Input / Enable pin, used to (a), enable the PTO1 Output, and (b), enable the engine speed control mode (if desired).
  - A PTO1 Output pin, used to physically power the PTO device under the proper conditions. Both functions are related, but somewhat independently setup:

A cab harness overlay is necessary, when installing a BBM in a cab that was not originally equipped with one.

For full functionality with PTO PTRD-D1 or PTRD-D2, it is necessary for the vehicle to be equipped with a Body Builder module (BBM).

To verify whether the vehicle has a VECU or a BBM, remove the Fuse and Relay Center (FRC) and look at the module located below it.

When a BBM ECU is added, three more PTO functions are added - refer to the appropriate section for more information on the BBM ECU and the ELCE-CK package. This section deals only with the PTO1 function contained within the VECU.

**Note:** The PTO1 function in the VECU is not usable with Cummins engines.

The PTO1 function is contained in all vehicles with a Volvo engine - VN and VHD. In addition, for VHD only, access to the PTO1 Input and Output circuits is also available in the body builder connector.

# Body Builder Harness with Auxiliary Switch Overlay (Dash), VN

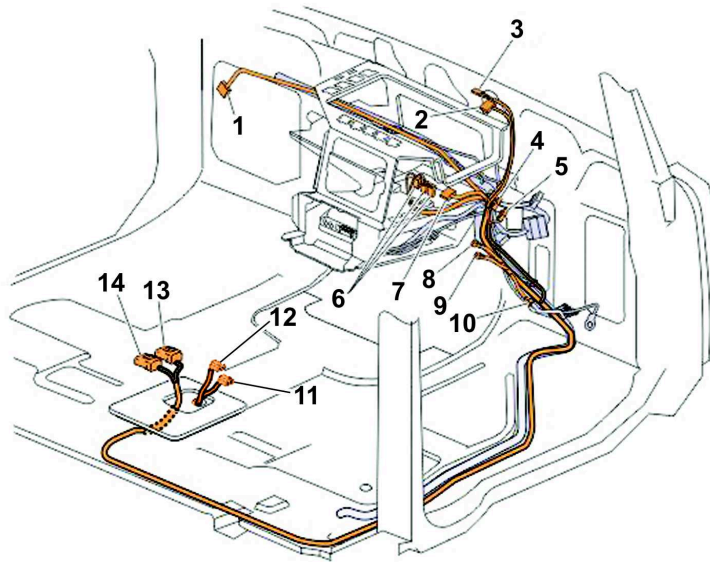

W9125674

- 1 Dual power take-off (PTO), Switch
- 2 Terminating Resistor (R08A)
- 3 Overlay Options (OPT3)
- 4 Body Builder Connector # 3 (Z03C)
- 5 Body Builder Connector # 4 (Z03D)
- 6 Body Builder Module (BBM) Electronic Control Unit (ECU)
- 7 Splice Pack (5K141B)
- 8 Main Cab (OPT5)
- 9 Main Cab (OPT1587)
- 10 Main Cab (MCBB)
- 11 Body Builder Connector # 1 (Z03A)
- 12 Body Builder Connector # 2 (Z03B)
- 13 Body Builder Connector # 3 (Z03C)
- 14 Body Builder Connector # 4 (Z03D)

**Note:** Mating kit 85146080 for connectors 3 and 4. Mating kit 85148537 for connectors 1 and 2.

# Power Take-off Controls

All Volvo trucks ordered from the factory with I-Shift or engine mounted PTOs will come pre-wired to the “primary” PTO controller in the Vehicle Electronic Control Unit (VECU). Also included are a dash mounted engagement switch, wiring to the VECU and wiring to the PTO solenoids. Engine speed is controlled via the cruise control (Stalk) switches and can be regulated up and down based off parameters set in the VECU. This configuration provides a limited control system for the PTO.



W9116680

PTO Dash Switch

Where vehicles need to drive multiple PTOs or have advanced controls for a single PTO, a Body Builder Module should also be specified - see included chart. If a vehicle is ordered without the Body Builder Module and it is later determined it is needed, an Aftermarket kit is available which converts a vehicle to the “Advanced” level controls.

**Note:** *The cost of installing the retrofit kit is significant, compared to having it factory installed.*

## Notes

---

---

---

---

---

---

"Basic" PTO Controls	"Advanced" Body Builder Module Controls
Capabilities:	Capabilities: (including "Basic" controls, plus :)
<ul style="list-style-type: none"> <li>• Cruise control (Stalk) PTO Engine Speed controls</li> <li>• Remote control of Stalk PTO speeds</li> <li>• Remote (wired) PTO controls: 1</li> </ul>	<ul style="list-style-type: none"> <li>• Remote (wired) PTO controls: up to 4 total</li> <li>• Additional remote control of PTO speeds</li> <li>• Remote throttle support</li> <li>• Accelerator Interlock (forced idle) input</li> <li>• Engine shutdown inputs: 2</li> <li>• Engine speed and torque limit inputs</li> <li>• Road speed limit input</li> <li>• PTO Interlock inputs: Neutral, High/Low split</li> <li>• Splitshaft (driveshaft-connected) PTO support</li> <li>• Vehicle speed proportional frequency output</li> <li>• Vehicle speed output switch</li> <li>• System warning output (activates on certain ECU errors)</li> <li>• Multi-function programmable output</li> </ul>
Hardware / Pre-wiring included:	Hardware / Pre-wiring included:
Vehicle ECU (VECU), with support for 1 PTO mode only	Body Builder Module (BBM) ECU, (in addition to the VECU)

## PTO Programming

There are multiple customer-changeable parameter settings for the VECU and BBM ECU.

For each ECU, there are two types:

"Vehicle" parameters; these are field-changeable using VCADS-Pro with a network connection. The network connection provides a centralized record of the changes maintained by Volvo Trucks North America.

"Customer" parameters; these are field-changeable using VCADS without a network connection. For each parameter, there is given Parameter Name - note that the name given here is intended to be the name which is presented in VCADS-Pro, but it may be different from the internal parameter name. In case of any questions, always use the parameter code to verify that it is the required parameter.

There are no "Vehicle" parameters for the BBM. All field-accessible parameters are customer-parameters and can be adjusted by VCADS-Pro without the need for a network connection.

Certain parameters will need to be set by the dealership prior to arriving to the body builder or customer. Here is a sample of parameter adjustable via the Premium Tech Tool (PTT) at the dealership.

# I-Shift PTO Parameter Programming

All parameters may not be applicable 0– dependent on PTO model and specification.

Verify 5 amp fuse is installed in F40 (prior to 11/10/09), otherwise F34.

## Parameter Valves

130= Transmission ECU

144 = Vehicle ECU

249 = BBM, Body Builder Module

MID	ID	Name	Value	Unit
130	GJG	Split Gear for Transmission PTO 1	Low/High/Select	
144	ANE	High idle/PTO/SS 0 resume	Enter speed	r/min
144	QP	PTO basic function enable	Yes	
144	RT	Enter step up factor	Enter speed	r/min
144	XN	Type of PTO	Transm. #1	
144	XO	Activate PTO output from vehicle control unit	Yes	
249	AA	PTO max engine speed set	860	r/min
249	BRQ	Activate functionality, split box	Yes	
249	DC	PTO min engine speed set	500	r/min
249	GQ	Engine speed limit value	900	r/min
249	GU	Engine speed limit enable	Yes	
249	GV	Vehicle speed limit enable	Yes	
249	IF	PTO engine speed trim factor	50	r/min/s
249	IG	Road speed limit optional vehicle speed set	5.0	mph

## Support Options:

- Online Body Builder support: eMedia Center Volvo Trucks North America- <http://www.volvotrucksemedia.com/>
- Volvo Dealers are to contact Tech Support by utilizing the eService application providing as much detail as possible.
- Volvo Dealers and Body Builders can contact the Body Builder Support line directly at 877-770-7575, Option 2, should additional support be needed. Be ready to provide your model and serial number.

# Calculation Example – Choose and Calculate a PTO/Pump Match

## Operating Conditions

Joe Sand, a hypothetical customer, is specifying a Volvo VHD tractor with a Volvo D13 435 hp engine and an I-Shift ATO2612D transmission. Sand's VHD will pull a 38 foot end dump trailer, which has the following requirements:

- Trailer requires a hydraulic flow rate of 25 gal/min = **Q**
- Working pressure of the system is 2500 psi = **p**
- For quiet and fuel efficient operation, the customer and the body builder consider a suitable engine rpm to be 800 rpm = **N<sub>eng</sub>**
- End dump trailer is always used when the vehicle is stationary, so a clutch dependent PTO will work
- A direct mount hydraulic pump is recommended by the body builder
- The engine is a D13 and the transmission is a Volvo I-Shift ATO2612D

**A.** Calculate the power requirement and specify a suitable PTO with ample capacity:

$$\text{Power (P)} = \frac{25(Q) \times 2500(p)}{1680} = 37.2 \text{ hp}$$

**B.** Next, check sufficient flow (**Q**) with a F1-61 hydraulic pump preferred by the customer (**D** = 3.63 cu.in./rev) with engine operating rpm (**N<sub>eng</sub>**) and ratio (**Z**) for selected PTO, T4XDMX, on the high speed split:

$$\text{Pump flow (Q)} = \frac{3.63(D) \times 800(N_{eng}) \times 1.72(Z)}{231} = 21.6 \text{ gpm}$$

The received flow (Q) is not sufficient for the requirement of 25 gpm. Three options can be used to correct the flow:

- 1 Increase the engine operating rpm (**N<sub>eng</sub>**).
- 2 Change to a faster PTO ratio (**Z**).
- 3 Use a larger displacement pump (**D**).

Option 3 was accepted by the customer and the pump was changed to one with a larger displacement (F1-81), on the high speed PTO split, which allows an even lower engine rpm for additional fuel savings:

$$\text{Pump flow (Q)} = 231 = 25.9 \text{ gpm}$$

**C.** Now check the PTO torque (**T**):

$$\text{Torque (T)} = \frac{4.98(D) \times 2500(p)}{74} = 168.2 \text{ lb-ft}$$

**D.** Last, check that the maximum pump speed is not exceeded:

$$\text{Pump speed (Np)} = 700 (N_{eng}) \times 1.72 (Z) = 1204 \text{ rpm}$$

This is acceptable as compared to the maximum pump speed on the manufacturer's pump specifications.

## Power Take-off Worksheet

Customer \_\_\_\_\_

Vehicle \_\_\_\_\_

Engine \_\_\_\_\_

Transmission \_\_\_\_\_

Equipment \_\_\_\_\_

**Constant Demands**

1. Equipment flow demand  $Q =$  \_\_\_\_\_ GPM

2. Working pressure  $p =$  \_\_\_\_\_ psi

**Selectable Variables**

3. PTO alternative ratio  $Z =$  \_\_\_\_\_

4. Pump alternatives  $D =$  \_\_\_\_\_ cu.in/rev.

5. Engine working speed  $N_{eng} =$  \_\_\_\_\_ rpm

**Notes**

---

---

---

---

---

---

# Electrical, PTO Programming

## PTO Types

For the purposes of this manual, PTO (Power Take-off) is a function to maintain engine speed regardless of engine load. Think of it as cruise control for the engine - only instead of maintaining a steady vehicle speed, it is maintaining engine speed. It is most often used to provide increased steady engine speed when operating auxiliary equipment such as hydraulic pumps or compressors. The term "PTO" has come to mean both the function of maintaining constant engine speed during use of auxiliary equipment, as well as a term for the auxiliary equipment itself.

There are two types of PTO engine speed control used in Volvo trucks:

**“Stalk” PTO** This type of PTO is standard equipment; it is initiated and controlled using the cruise control "ON/OFF", "SET+", "SET-", and "RESUME" stalk switches. Manufacturers refer to this function by different names - Mack calls it "Electronic Hand Throttle" (EHT), some European manufacturers (including Volvo Trucks in Sweden) call it a "high idle" function. In this manual we will refer to it as "Stalk PTO", even though some of the parameters for programming this function will refer to it as "high idle". (Note that in the North American market, the term "high idle" usually refers to the maximum possible engine speed under no-load conditions).

**“Remote” or “Wired” PTO** This type PTO is most commonly associated with the engagement of engine or transmission "Wired" PTO driven accessories, where the user wishes to "remotely" activate the engine speed control function. It is usually accomplished by wiring the auxiliary equipment to the PTO function controller (VECU, BBM ECU, or Engine ECU) so that engaging one will automatically activate the other.

How each of these different PTO functions operate will depend upon the installed engine. For Volvo engines, the PTO functions are split between the Engine ECU, VECU and (if equipped) the BBM ECU. Cummins engines, on the other hand, contain all of the PTO functionality within the Engine ECU itself.

## Stalk PTO

The VECU reads the cruise control stalk switch states, and commands the engine into PTO mode when conditions are right. These conditions are programmable in the VECU and might include a maximum vehicle speed, park brake set or not, etc. The engine PTO 'set speed' is selected by either pressing the cruise control "RESUME" button, or by using the accelerator pedal to get the desired engine speed and pressing one of the cruise control "SET" buttons (either SET+ or SET-). Once the PTO function is active, the SET+ or SET- buttons can be used to adjust the PTO engine speed (within limits).

## Remote / Wired PTO

This type of PTO speed control works similarly to 'Stalk PTO', except that the function is activated by applying an external signal to a dedicated PTO input pin on the VECU. The set speed can be adjusted using the cruise control SET+ or SET- buttons, as above. If the vehicle is equipped with a Body Builder Module (BBM) ECU, then three (3) additional PTO functions are available. With the 1 PTO function of the VECU, a total of four (4) PTO 'modes' exist. (Each 'mode' offers the ability to independently select a different set speed and control independent outputs (explained below)). A sub-function of the 'wired' PTOs in the VECU and BBM ECU is the ability to activate PTO "outputs". Traditionally, the auxiliary device (PTO pump, bypass solenoid, etc.) is wired so as to be activated by the same switch which initiates the engine speed control function. This means that the hardware will be engaged whenever the switch is on, even if the engine speed is not being controlled (the hardware does not know whether the engine is running or not). There also is no protection against an input switch that has been accidentally activated. Using the PTO "Output Control" function of the VECU and BBM ECU, it is possible to prevent engagement of the auxiliary equipment until certain conditions are met - park brake set, engine speed within a certain range, etc. This is accomplished by controlling the auxiliary equipment with the VECU or BBM ECU, instead of directly from a switch. The ECUs still read the switch input, though, and will only allow the auxiliary device to engage when conditions are right.

# PTO Setup in VECU (both “stalk” PTO and wired/remote PTO1)

## Worksheet 1, Part 1 VECU

Step:	Action:	Set VECU Parameter:	Allowable Range:	Default Value:	Next Step:
<b>Under what conditions will the PTO1 be used:</b>					
A	Stationary Only (with Parking Brake set):	<b>AZG = 1 and XM = 1</b>			C
	While moving, or do not want to require PB set:	<b>AZG = 0 and XM = 0</b>			B
B	Maximum allowed vehicle speed while in PTO:	<b>DA = desired max. vehicle speed in PTO</b>	0 ~ 30 km/h (0 —19 mph)	12 km/h (7 mph)	C
<b>Does this application require service brake override of PTO?</b>					
C	No, service brake should have no effect:	<b>XP = 0</b>			D
	Yes, service brake should kick-out PTO mode:	<b>XP = 1</b>			D
D	What should be the maximum allowed engine speed when trimming PTO set speed? (See Note 1)?:	<b>AND = desired max. adjustable speed</b>	500 ~ 2500 RPM	2500 RPM	E
E	What should be the minimum allowed engine speed when trimming PTO set speed?:	<b>ANF = desired min. adjustable speed</b>	500 ~ AND RPM	500 RPM	F
F	What should be the default PTO set speed when the function is initiated?:	<b>ANE = desired default engine speed</b>	within range ANF ~ AND	750 RPM	G
G	While adjusting the PTO set speed with the stalk switches, what resolution is desired (what RPM change for each button press?) :	<b>RT = desired RPM change for each press of SET + / —</b>	0 ~ 250 RPM	50 RPM	H
<b>How will PTO be engaged?:</b>					
H	Stalk switches only: (See Note 2)				DONE
	Dash switch or wired/remote activation: (Use this if setting up factory-installed side-engine PTO)	<b>QP = 1</b>			J
<b>When initiating PTO with the dash switch (or remote activation), do you want the PTO Engine Speed Control to be engaged at the same time?</b>					
J	Yes:	<b>AZH = 1</b>			Go to Part 2
	No -will use stalk PTO speed control separately:	<b>AZH = 0</b>			

**Note:** 1: Parameter "AND" is the maximum allowed engine speed while using the SET + / SET - buttons to trim the PTO set speed; it is NOT the maximum allowed overall engine RPM while in PTO. If the user will be using the accelerator pedal or a hand-throttle for controlling the PTO pump flow rate, a BBM ECU will be required in order to impose an overall maximum engine speed while in PTO.

**Note:** 2: When PTO is to be engaged using the Stalk switches ONLY, there is no possibility to use the VECU's PTO Output to control a PTO pump or bypass solenoid; if this control is desired, it is suggested that the PTO be engaged by a dash switch or remote activation which is wired to the VECU's PTO1 Input.

## Worksheet 1, Part 2 VECU

Step:	Action:	Set VECU Parameter:	Allowable Range:	Default Value:	Next Step:
A	<b>Will a device (example: PTO pump or bypass solenoid) be connected to and controlled by the VECU while PTO1 is engaged? See Note 3.</b>				
	Yes:	XO = 1			B
	No:	XO = 0			Done
B	<b>Is the vehicle equipped with a factory-installed side-engine PTO?</b>				
	Yes (Vehicle is pre-wired all the way to PTO):				Done
	No (Customer will need to provide wiring:				C
C	<b>Is the vehicle a VN or VHD?</b>				
	VN:				D
	VHD:				E
D	On VN vehicles, the PTO output circuit (ckt 639) runs through the 102-way cab pass thru; A 2-way connector (ckts 639 and 0PTO) can be found capped and tied to the under-hood harness near the starter relay on the firewall. Install jumper harness 20448203 if desired to extend that circuit to a PTO device. If using the pre-wired PTO dash switch wiring, install switch part number 8158235 and one of the available switch legends. The PTO dash switch connector can be found behind the switch panel to the left of the steering wheel. Observe notes regarding use of the PTO Output circuit in the PTO section of the manual.				Done
E	On VHD vehicles, the PTO output circuit is spliced and can be found in two locations: ? Cavity M of Body Builder Connector #1 (coming up between the seats) -circuit 639-A. ? A PTO jumper harness which is tied off on the under-hood harness near the starter relay on the firewall. Only use one or the other, not both ! DO NOT use the flying lead labelled "Twin PTO" –this is for a special application used for twin-flow (PTES-T53) only. If using the pre-wired PTO dash switch wiring, install switch part number 8158235 and one of the available switch legends. The PTO dash switch connector can be found behind the switch panel to the left of the steering wheel. Observe notes regarding use of the PTO Output circuit in the PTO section of the manual.				Done

**Note: 3:** If no device is connected to VECU pin PB-16 and controlled by the VECU while the PTO1 is engaged, answer "No" here. If you answer "Yes" but there is no device connected to the PB-16 Output, the PTO1 function might not operate as desired.

# BBM ECU PTO SETUP

If the vehicle is equipped with a BBM ECU in addition to the VECU, there are more options available for the PTO within the VECU (PTO1). Use this worksheet to determine if the additional features are needed, and if so what steps are needed to complete the programming.

## Definitions:

**EDGE triggering:** If the PTO input is active, then drops out for any reason –example, the park brake is released and it is a condition for the PTO to remain active –then once the park brake is set again the user will have to turn OFF and back ON the PTO input signal. This is best for most interlocks as it will prevent accidental re-engagement of the PTO should conditions change.

**LEVEL triggering:** While the PTO input signal (switch) is active, the PTO will engage as soon as all other conditions are met. For example, if the park brake is released and then re-applied, the PTO will re-engage as soon as the park brake is re-engaged (assuming that park brake being set is a condition for engagement).

## Worksheet 2, Part 1 - PTO1 SETUP WITH A BBM ECU

**Note:** All of these parameters are programmed in the BBM ECU, not the VECU.

Step:	Action:	Set BBM ECU Parameter:	Allowable Range:	Default Value:	Next Step:
A	<b>Review the list of additional PTO1 features and conditions (Note 1, below);</b>				
	Need the extra features offered by BBM's PTO1:	<b>IC = 1</b>			B
	Don't need the extra features:				Done
B	<b>Will PTO1 input be EDGE or LEVEL triggered? (see descriptions at beginning of section); If unsure or don't care, use EDGE triggering.</b>				
	EDGE triggering	<b>YJ = 1 (Default)</b>			C
	LEVEL triggering	<b>YJ = 0</b>			C
C	<b>Under what conditions will this PTO be used? (previous programming told the VECU only, not the BBM ECU)</b>				
	Stationary Only (with Parking Brake set)	<b>HH = 1</b> Operating Instructions — When a truck is being pushed in neutral, hold the + button for two seconds while in neutral, and then let go. Move the gear selector from neutral to drive, at this point you can choose the start gear. This will override the brake interlock, when you step on the throttle you will be able to accelerate without braking. Every time you want to			D

Step:	Action:	Set BBM ECU Parameter:	Allowable Range:	Default Value:	Next Step:
		override the brake interlock the same action will be taken, because the instant the truck moves forward into drive the brake interlock will be re-engaged. This can only be done with a premium shifter.			
	While Moving	HH = 0			D
	<b>Does this application require service brake override of the PTO1?</b>				
D	Yes, applying service brake should disengage engine speed control	BRR = 1			E
	No, service brake position should make no difference	BRR = 0 (Default)			E
	<b>Does this application require clutch pedal override of the PTO1?</b>				
E	Yes, pressing the clutch should disengage engine speed control	BRV = 1			F
	No, clutch pedal position should make no difference	BRV = 0 (Default)			F
	<b>Is a gradual RPM change desired upon PTO entry &amp; exit ? (as opposed to an aggressive "step change" in RPM)</b>				
F	Yes	HZ = Desired ramp	0 ~ 250 RPM/Sec	0	G
	No	HZ = 0 (Default)			G
	<b>Is a PTO exit time delay desired ? (delay from when the PTO1 input becomes inactive, until the engine RPM begins to ramp back down to idle)</b>				
G	Yes	HE = Desired delay	0 ~ 100 Seconds	0	H
	No	HE = 0 (Default)			H
	<b>Does the application require that one of the other PTO Outputs controlled by the BBM ECU (PTOs 2, 3, or 4) be engaged BEFORE this PTO is allowed to engage?</b>				
H	Yes	HT = 1			J
	No	HT = 0 (Default)			J
J	<b>What should be the maximum allowed engine speed when trimming PTO set speed? (NOTE 2)</b>	AA = desired max. adjustable speed	500 ~ 2500 RPM	2500 RPM	K
K	<b>What should be the minimum allowed engine speed when trimming PTO set speed?</b>	DC = desired min. adjustable speed	500 ~ AA RPM	500 RPM	L

Step:	Action:	Set BBM ECU Parameter:	Allowable Range:	Default Value:	Next Step:
L	What should be the default PTO set speed when the PTO1 function is engaged?	HB = Desired default engine speed	within range DC ~ AA	800 RPM	M
M	When adjusting the PTO set speed with the BBM's remote INC and DEC inputs, what speed change ramp is desired?	IF = RPM adjust ramp change for BBM ECU (in RPM per Second)	0 ~ 250 RPM/Sec	50 RPM/Sec	Done

**Note:** Additional PTO1 functions which are available only with the BBM ECU's PTO1:

- Ability to make the PTO1 speed control service brake and/or clutch pedal dependent
- PTO entry and exit RPM ramp (0 ~ 250 RPM per Second)
- PTO exit time delay (0 ~ 100 seconds)
- Choice of "edge" or "level" triggering on the input; see descriptions at beginning of section
- Possibility to require that another PTO Output controlled by the BBM ECU (PTO 2 ~ 4) is engaged first

To utilize these additional PTO1 features, the circuit which activates PTO1 in the VECU must be moved over and connected to the BBM ECU instead! The PTO1 Output continues to be controlled by the VECU.

**Note:** 2: Parameter "P1TZ4" is the maximum allowed engine speed while using the BBM's remote speed INC/DEC inputs to adjust PTO set speed; it is NOT the maximum allowed overall engine RPM while in PTO. See ENGINE SPEED LIMIT function of the BBM ECU if such an overall engine speed limit is required. **The limits programmed in the BBM ECU are also different than the min/max speed limits programmed in the VECU when using the stalk SET+ and SET- switches to trim the PTO set speed; see VECU programming for information on parameters "ANF"(P1VTP) and "AND"(P1VTR).**

## Notes

---



---



---



---



---



---

## Worksheet 2, Part 2 - PTO2 SETUP WITH A BBM ECU

**Note:** Continue through the remaining portions of this worksheet if there are more PTOs to setup. All PTO programming in the BBM ECU (with the exception of min / max speed adjustment range, parameters AA and DC) is done independently for each of the PTO modes.

**Note:** The remaining PTO functions (PTO 2 ~ PTO4) are self-contained within the BBM ECU and do not share any functionality with the VECU.

Step:	Action:	Set BBM ECU Parameter:	Allowable Range:	Default Value:	Next Step:
A	<b>See steps (J) and (K) of "Part 1 -PTO1 setup with BBM ECU" worksheet for programming of the minimum and maximum engine speed adjustment range (parameters AA and DC) while in PTO mode; these values apply to all PTOs (1 ~ 4) within the BBM ECU.</b>				B
B	<b>Will PTO2 be used at all?</b>				
	Yes:	<b>ID =1</b>			C
	No:	<b>ID =0</b>			Go to PART 3
C	<b>Under what conditions will PTO2 be used?</b>				
	Stationary Only (with Parking Brake set)	<b>HI =1, YU =1</b>			E
	While Moving, or do not want to require PB set:	<b>HI =0, YU =0</b>			D
D	<b>Maximum allowed vehicle speed while in PTO: Note that this only affects when the PTO2 Output becomes de-activated, not the PTO2 engine speed control function.</b>	<b>YZ = desired max. vehicle speed in PTO</b>	2 ~ 130 km/h	90 km/h	E
E	<b>Does this application require service brake override of the PTO2?</b>				
	Yes, applying service brake should disengage engine speed control	<b>BRS = 1</b>			F
	No, service brake position should make no difference	<b>BRS =0 (default)</b>			F
F	<b>Does this application require clutch pedal override of the PTO2?</b>				
	Yes, pressing the clutch should disengage engine speed control	<b>BRW =1</b>			G
	No, clutch pedal position should make no difference	<b>BRW = 0 (default)</b>			G
G	<b>Keeping in mind the limits set in step (A) above for the min and max adjustment speed, what should be the default PTO set speed for PTO2?</b>	<b>HC = desired default PTO engine set speed</b>	Within range defined by <b>DC ~ AA</b>	1000 RPM	H
H	<b>Will the PTO2 be EDGE or LEVEL triggered? (see descriptions at beginning of section); If unsure or don't care, use EDGE triggering.</b>				
	EDGE triggering:	<b>YK =1,YT =1</b>			J
	LEVEL triggering:	<b>YK =0,YT =0</b>			J
J	<b>Does the application require that one of the other PTO Outputs controlled by the BBM ECU (PTOs 1, 3, or 4) be engaged BEFORE this PTO is allowed to engage?</b>				
	Yes:	<b>HU =1</b>			K
	No:	<b>HU = 0 (default)</b>			K

Step:	Action:	Set BBM ECU Parameter:	Allowable Range:	Default Value:	Next Step:
K	<b>Is a gradual RPM change desired upon PTO entry &amp; exit ? (as opposed to an aggressive "step change" in RPM)</b>				
	Yes:	IA = Desired ramp	0 ~ 250 RPM/Sec	0	L
	No:	IA = 0 (Default)			L
L	<b>Is a PTO exit time delay desired? (delay from when the PTO2 input becomes inactive, until the engine RPM begins to ramp back down to idle)</b>				
	Yes:	HF = Desired delay	0 ~ 100 Seconds	0	M
	No:	HF = 0 (Default)			M
M	<b>Will a device (ex: PTO pump or bypass solenoid) need to be controlled while PTO2 is engaged?</b>				
	Yes:				N
	No:				Go to PART3
N	<b>Should the transmission be in NEUTRAL before the PTO2 device is allowed to engage?</b>				
	Yes:	YV =1			P
	No:	YV = 0 (Default)			Q
P	<b>Review the requirements for the 'NEUTRAL GEAR' Input to the BBM ECU, then return here; Go to step 'S' after reviewing step 'Q' (normally not applicable since said want transmission in Neutral)</b>				Q>S
Q	<b>Should the transmission be in a Low Split gear before the PTO2 device is allowed to engage? NOTE that this status input to the BBM ECU could be used for other forms of PTO interlocks such as a door status, control arm position, etc.</b>				
	Yes:	YW =1			R
	No:	YW = 0 (Default)			S
R	<b>Review the requirements for the 'LOW SPLIT GEAR' Input to the BBM ECU, then return here; If using this input for alternate uses, read and follow all safety precautions for the PTO interlocks.</b>				S
S	<b>A mandatory condition before the PTO2 device can be engaged for the first time, is that the engine speed be above a certain RPM for at least 2 seconds;</b>				
	What should this RPM value be?	YX Desired RPM	300 ~ 700 RPM	500 RPM	T
T	<b>Also before the PTO2 device can be engaged for the first time, the engine speed must be below a certain RPM -</b>				
	What should this RPM value be?	YY = Desired Max. RPM	500 ~ 2500 RPM	2500 RPM	U
U	<b>Should the max engine speed selected above (step (T)) be treated as an overall engine speed limit while the PTO2 output is engaged? (normally it is only treated as an 'entry' condition)</b>				
	Yes:	ZB =1			V
	No:	ZB = 0 (Default)			V
V	<b>Review all hardware and circuit requirements for connecting the PTO2 input and output functions</b>				Go to PART3

## Worksheet 2, Part 3 - PTO3 SETUP WITH A BBM ECU

Step:	Action:	Set BBM ECU Parameter:	Allowable Range:	Default Value:	Next Step:
A	See steps (J) and (K) of "Part 1 -PTO1 setup with BBM ECU" worksheet for programming of the minimum and maximum engine speed adjustment range (parameters AA and DC) while in PTO mode; these values apply to all PTOs (1 ~ 4) within the BBM ECU.				B
B	<b>Will PTO3 be used at all?</b>				
	Yes:	IE =1			C
	No:	IE =0			Go to PART4
C	<b>Under what conditions will PTO3 be used?</b>				
	Stationary Only (with Parking Brake set)	HJ =1, ZD =1			E
	While Moving, or do not want to require PB set:	HJ =0,ZD =0			D
D	<b>Maximum allowed vehicle speed while in PTO: Note that this only affects when the PTO2 Output becomes de-activated, not the PTO2 engine speed control function.</b>	ZI = desired max. vehicle speed in PTO	2 ~ 130 km/h	90 km/h	E
E	<b>Does this application require service brake override of the PTO3?</b>				
	Yes, applying service brake should disengage engine speed control	BRT =1			F
	No, service brake position should make no difference	BRT = 0 (default)			F
F	<b>Does this application require clutch pedal override of the PTO3? Operating Instructions — When a truck is being pushed in neutral, hold the + button for two seconds while in neutral, and then let go. Move the gear selector from neutral to drive, at this point you can choose the start gear. This will override the brake interlock, when you step on the throttle you will be able to accelerate without braking. Every time you want to override the brake interlock the same action will be taken, because the instant the truck moves forward into drive the brake interlock will be re-engaged. This can only be done with a premium shifter.</b>				
	Yes, pressing the clutch should disengage engine speed control	BRX =1			G
	No, clutch pedal position should make no difference	BRX =0 (default)			G
G	<b>Keeping in mind the limits set in step(A) above for the min and max adjustment speed, what should be the default PTO set speed for PTO2?</b>	HD = desired default PTO engine set speed	Within range defined by DC ~ AA		H
H	<b>Will the PTO3 input be EDGE or LEVEL triggered? (see descriptions at beginning of section); If unsure or don't care, use EDGE triggering.</b>				
	EDGE triggering:	YL =1ZC =1 (default)			J
	LEVEL triggering:	YL =0ZC=0 (default)			J
J	<b>Does the application require that one of the other PTO Outputs controlled by the BBM ECU (PTOs 1, 2, or 4) be engaged BEFORE this PTO is allowed to engage?</b>				
	Yes:	HV =1			K

Step:	Action:	Set BBM ECU Parameter:	Allowable Range:	Default Value:	Next Step:
	No:	HV =0 (default)			K
K	<b>Is a gradual RPM change desired upon PTO entry &amp; exit ? (as opposed to an aggressive "step change" in RPM)</b>				
	Yes:	IB =Desired ramp	0 ~ 250 RPM/Sec		L
	No:	IB = 0 (default)			L
L	<b>Is a PTO exit time delay desired ? (delay from when the PTO3 input becomes inactive, until the engine RPM begins to ramp back down to idle)</b>				
	Yes:	HG =Desired ramp	0 ~ 100 Seconds	0	M
	No:	HG = 0 (default)			M
M	<b>Will a device (ex: PTO pump or bypass solenoid) need to be controlled while PTO3 is engaged?</b>				
	Yes:				N
	No:				Go to PART4
N	<b>Should the transmission be in NEUTRAL before the PTO3 device is allowed to engage?</b>				
	Yes:	ZE =1			P
	No:	ZE = 0 (default)			Q
P	<b>Review the requirements for the 'NEUTRAL GEAR' Input to the BBM ECU, then return here; Go to step 'S' after reviewing step 'Q' (normally not applicable since said want transmission in Neutral)</b>				Q>S
Q	<b>Should the transmission be in a Low Split gear before the PTO3 device is allowed to engage? NOTE that this status input to the BBM ECU could be used for other forms of PTO interlocks such as a door status, control arm position, etc.</b>				
	Yes:	ZF =1			R
	No:	ZF = 0 (Default)			S
R	<b>Review the requirements for the 'LOW SPLIT GEAR' Input to the BBM ECU, then return here; If using this input for alternate uses, read and follow all safety precautions for the PTO interlocks.</b>				S
S	<b>A mandatory condition before the PTO3 device can be engaged for the first time, is that the engine speed be above a certain RPM for at least 2 seconds;</b>				
	What should this RPM value be?	ZG = Desired RPM	300 ~ 700 RPM	500 RPM	T
T	<b>Also before the PTO3 device can be engaged for the first time, the engine speed must be below a certain RPM</b>				
	What should this RPM value be?	ZH = Desired Max. RPM	500 ~ 2500 RPM	2500 RPM	U

Step:	Action:	Set BBM ECU Parameter:	Allowable Range:	Default Value:	Next Step:
U	<b>Should the max engine speed selected above (step (T)) be treated as an overall engine speed limit while the PTO3 output is engaged? (normally it is only treated as an 'entry' condition)</b>				
	Yes:	<b>ZK =1</b>			V
	No:	<b>ZK = 0 (default)</b>			V
V	<b>Review all hardware and circuit requirements for connecting the PTO3 input and output functions</b>				Go to PART4

*Notes*

---



---



---



---



---

## Worksheet 2, Part 4 -PTO4 SETUP WITH A BBM ECU

Step:	Action:	Set BBM ECU Parameter:	Allowable Range:	Default Value:	Next Step:
A	See steps (J) and (K) of "Part 1 -PTO1 setup with BBM ECU" worksheet for programming of the minimum and maximum engine speed adjustment range (parameters AA and DC) while in PTO mode; these values apply to all PTOs (1 ~ 4) within the BBM ECU.				B
B	<b>Will PTO4 be used at all?</b>				
	Yes:	<b>YO =1</b>			C
	No:	<b>YO =0</b>			Done
C	<b>Under what conditions will PTO4 be used?</b>				
	Stationary Only (with Parking Brake set)	<b>YQ =1, ZM =1</b>			E
	While Moving, or do not want to require PB set:	<b>YQ =0, ZM =0</b>			D
D	<b>Maximum allowed vehicle speed while in PTO: Note that this only affects when the PTO4 Output becomes de-activated, not the PTO4 engine speed control function.</b>	<b>ZR = desired max. vehicle speed in PTO</b>	2 ~ 130 km/h	90 km/h	E
E	<b>Does this application require service brake override of the PTO4?</b>				
	Yes, applying service brake should disengage engine speed control	<b>BRU =1</b>			F
	No, service brake position should make no difference	<b>BRU = 0 (default)</b>			F
F	<b>Does this application require clutch pedal override of the PTO4?</b>				
	Yes, pressing the clutch should disengage engine speed control	<b>BRY = 1</b>			G
	No, clutch pedal position should make no difference	<b>BRY = 0 (default)</b>			G
G	<b>Keeping in mind the limits set in step(A) above for the min and max adjustment speed, what should be the default PTO set speed for PTO4?</b>	<b>YN = desired default PTO engine set speed</b>	Within range defined by <b>DC ~ AA</b>	1400 RPM	H
H	<b>Will the PTO4 be EDGE or LEVEL triggered? (see descriptions at beginning of section); If unsure or don't care, use EDGE triggering.</b>				
	EDGE triggering:	<b>YM =1, ZL =1 (default)</b>			J
	LEVEL triggering:	<b>YM =0, ZL =0 (default)</b>			J
J	<b>Does the application require that one of the other PTO Outputs controlled by the BBM ECU (PTOs 1, 2, or 3) be engaged BEFORE this PTO is allowed to engage?</b>				
	Yes:	<b>YP =1</b>			K
	No:	<b>YP =0 (default)</b>			K
K	<b>Is a gradual RPM change desired upon PTO entry &amp; exit? (as opposed to an aggressive "step change" in RPM)</b>				
	Yes:	<b>YS =Desired ramp</b>	0 ~ 250 RPM/Sec	0	L

Step:	Action:	Set BBM ECU Parameter:	Allowable Range:	Default Value:	Next Step:
	No:	YS = 0 (default)			L
L	<b>Is a PTO exit time delay desired? (delay from when the PTO4 input becomes inactive, until the engine RPM begins to ramp back down to idle)</b>				
	Yes:	YR = Desired delay	0 ~ 100 Seconds	0	M
	No:	YR = 0 (default)			M
M	<b>Will a device (ex: PTO pump or bypass solenoid) need to be controlled while PTO4 is engaged?</b>				
	Yes:				N
	No:				Done
N	<b>Should the transmission be in NEUTRAL before the PTO4 device is allowed to engage?</b>				
	Yes:	ZN =1			P
	No:	ZN =0 (default)			Q
P	<b>Review the requirements for the 'NEUTRAL GEAR' Input to the BBM ECU, then return here; Go to step 'S' after reviewing step 'Q' (normally not applicable since said want transmission in Neutral)</b>				Q>S
Q	<b>Should the transmission be in a Low Split gear before the PTO4 device is allowed to engage? NOTE that this status input to the BBM ECU could be used for other forms of PTO interlocks such as a door status, control arm position, etc.</b>				
	Yes:	ZO =1			R
	No:	ZO = 0 (default)			S
R	<b>Review the requirements for the 'LOW SPLIT GEAR' Input to the BBM ECU, then return here; If using this input for alternate uses, read and follow all safety precautions for the PTO interlocks.</b>				S
S	<b>A mandatory condition before the PTO4 device can be engaged for the first time, is that the engine speed be above a certain RPM for at least 2 seconds;</b>				
	What should this RPM value be?	ZP = Desired RPM	300 ~ 700 RPM	500 RPM	T
T	<b>Also before the PTO4 device can be engaged for the first time, the engine speed must be below a certain RPM -</b>				
	What should this RPM value be?	ZQ = Desired Max. RPM	500 ~ 2500 RPM	2500 RPM	U
U	<b>Should the max engine speed selected above (step (T)) be treated as an overall engine speed limit while the PTO4 output is engaged? (normally it is only treated as an 'entry' condition)</b>				
	Yes:	ZT =1			V
	No:	ZT = 0 (default)			V
V	<b>Review all hardware and circuit requirements for connecting the PTO4 input and output functions</b>				Done

# Regeneration in PTO Mode

When a vehicle is being operated in the PTO mode and a diesel particulate filter (DPF) regeneration is commanded (either automatically or manually), the engine must be run at a speed above the minimum speeds listed in the tables below (according to the altitude and ambient temperature in which the vehicle is being operated) so that sufficient heat can be generated in the catalyst for regeneration to occur.

This is important to note, because the rated speed of the PTO must not be exceeded. For example; if the maximum rated speed of the PTO is 900 rpm, the regeneration will not occur while the PTO is engaged. When specifying a PTO for a chassis equipped with a DPF, a PTO having a maximum rated speed above the minimum engine speed listed in the tables below must be specified.

## D11F

	Ambient Temperatures in Degrees C (F)		
	-30° C (-22° F)	0° C (32° F)	30° C (86° F)
Altitude in Meters (ft)	Minimum Engine Speed, RPM		
Sea Level	1050	1050	1050
1951 (6400)	1100	1100	1100
4267 (14,000)	1300	1300	1300

## D13F

	Ambient Temperatures in Degrees C (F)		
	-30° C (-22° F)	0° C (32° F)	30° C (86° F)
Altitude in Meters (ft)	Minimum Engine Speed, RPM		
Sea Level	1300	1200	1150
1951 (6400)	1300	1300	1200
4267 (14,000)	1300	1300	1400

## D11H

	Ambient Temperatures in Degrees C (F)		
	-30° C (-22° F)	0° C (32° F)	30° C (86° F)
Altitude in Meters (ft)	Minimum Engine Speed, RPM		
Sea Level	1200	1200	1200
1951 (6400)	1200	1200	1200
4267 (14,000)	1250	1250	1250

**D13H**

	Ambient Temperatures in Degrees C (F)		
	-30° C (-22° F)	0° C (32° F)	30° C (86° F)
Altitude in Meters (ft)	Minimum Engine Speed, RPM		
Sea Level	1250	1250	1250
1951 (6400)	1325	1325	1325
4267 (14,000)	1370	1370	1370

**OBD13, OBD15, D11J**

	Ambient Temperatures in Degrees C (F)			
	-30° C (-22° F)	-20° C (-4° F)	-10° C (14° F)	-1° C (30° F) and above
Altitude in Meters (ft)	Minimum Engine Speed, RPM			
Up to 500 (1650)	1050	1050	1050	1050
1500 (4900)	1150	1150	1150	1150
2500 (8200)	1250	1250	1250	1250
4270 (14,000)	1300	1300	1300	1300

**OBD13, OBD15, D13J**

	Ambient Temperatures in Degrees C(F)			
	-30° C (-22° F)	-20° C (-4° F)	-10° C (14° F)	-1° C (30° F) and above
Altitude in Meters (ft)	Minimum Engine Speed, RPM			
Up to 500 (1650)	1100	1100	1100	1100
1500 (4900)	1175	1175	1175	1175
2500 (8200)	1251	1251	1251	1251
4270 (14,000)	1325	1325	1325	1325

## Manual Stationary Regeneration

If manual stationary regenerations with the PTO engaged are required, the vehicle must be configured as follows:

- For US07 and US10, parameter code JAC (Enable Manual Regen during PTO) must be set to “TRUE” in VCADS. For OBD13 and beyond, it no longer exists and the feature is on by default.  
**Note:** A connection to central systems is necessary in order to set parameter code JAC.
- The PTO electrical interface must be connected to the vehicle electronic control unit (VECU).
- Manual stationary regeneration must be initiated by using the stalk switch.
- The electronic hand throttle (engine speed control) must be active and set to an engine speed greater than the minimum speeds listed in the preceding charts, taking into account the altitude and ambient temperatures in which the vehicle is being operated.

If the vehicle is not configured as listed above, manual stationary regeneration with the PTO engaged will not occur. When regeneration does not take place, the DPF will become soot-loaded, resulting in engine derate and eventual engine shutdown.

## Chassis Equipped with Clean Idle Engine

Effective January 2008, the California Air Resources Board (CARB) requires that vehicles operated in California be equipped with engines having tamper-resistant software which limits the time at which the engine can idle at speeds above low idle (550–700 rpm). With the vehicle stationary and without a PTO engaged, idle time at speeds above low idle are limited to approximately 15 minutes. After 15 minutes, the Engine Management System (EMS) will command the engine to revert back to low idle.

When installing a PTO on a vehicle equipped with a Clean Idle engine, it is very important that the PTO be activated by a switch that provides both engagement and speed inputs to the VECU so that the EMS knows when, and at what speed the PTO is operating. If the PTO is activated through a pneumatic actuator with no electrical input to the vehicle control system, the Clean Idle function will command the engine back to low idle after approximately 15 minutes. This may result in possible damage to the PTO, equipment or to the product being unloaded.

## Aftertreatment System Conditioning (ASC)

Effective mid-March 2008, an Aftertreatment System Conditioning (ASC) function was implemented into the engine management system software. This function increases engine speed periodically in order to increase the temperature inside the diesel particulate filter so that unburned diesel fuel can be oxidized. On these chassis, it is important that PTO be activated by a switch which provides PTO engagement and speed input to the VECU so that the EMS knows the status of the PTO. If the engine speed control and PTO engage inputs are not enabled and the PTO is engaged, the ASC function will increase engine speed when commanded, resulting in damage to the PTO, equipment or to the product being unloaded. The ASC function will not increase engine speed if the heat mode target speed is greater than the speed selected with the engine speed control.

## Summary of PTO Engagement Information

- For vehicles equipped with diesel particulate filter, the PTO **MUST** be activated by a switch that provides both engagement and speed information to the VECU when the PTO is engaged, and the vehicle operator must use engine speed control to set engine speed when the PTO is in operation.
- For vehicles equipped with diesel particulate filter, and prolonged periods of engine idle time are required, the engine speed control **SHOULD NOT** be used to increase engine speed. The engine must be allowed to idle as normal. If prolonged engine idling is necessary, it is recommended that the EMS ECU be programmed with CARB compliant files.
- For vehicles with a diesel particulate filter and a Clean Idle engine, the PTO **MUST** be activated by a switch that provides engagement and speed information to the VECU when the PTO is engaged, and the vehicle operator **MUST** use engine speed control to set engine speed when the PTO is in operation.

**Note:** The optional PTO dedicated switches provide input information to the VECU only. The VECU cannot provide a signal to engage a PTO.

**Note:** In general, a front engine-mounted PTO does not require speed or engagement information to the VECU except for those instances where the engine speed must **NOT** be lowered during PTO operation. As an example, in concrete mixer applications when an increase in engine speed is required to rotate the barrel at a faster speed, PTO input to the VECU is required and engine speed control must be enabled, otherwise, engine speed may either revert to low idle or may increase due to the lack of interaction with the engine management system.

## Paver Assist for I-Shift: New Generation AMT-F



W9118175

Certain dump trucks are used to re-fill a road paver's hopper throughout the paving process. In this case, the paver pushes the dump truck. When the dump truck needs to move away from the paver, it is important that it does not cause the paver to change speed or the paver will leave a ripple in the road surface. Paver Assist allows the driver to go from neutral to drive without first applying the brake.

Paver Assist is **not** enabled by default. To enable Paver Assist, use Premium Tech Tool to toggle the desired parameter below.

Paver assist can be enabled via the parameter (P1OM4 = True) setting in Premium Tech Tool (PTT). If parameter (P1OM4) is not visible in Premium Tech Tool contact Body Builder Support @ 877-770-7575.

**Operating Instructions** — When a truck is being pushed in neutral, hold the + button for two seconds while in neutral, and then let go. Move the gear selector from neutral to drive, at this point you can choose the start gear. This will override the brake interlock, when you step on the throttle you will be able to accelerate without braking. Every time you want to override the brake interlock the same action will be taken, because the instant the truck moves forward into drive the brake interlock will be re-engaged. This can only be done with a premium shifter.

Parameter	Value	Effect	Result
P10M4	TRUE	Deactivates brake interlock	Vehicle can go from neutral to drive without brake application (Paver Assist enabled).
P10M4	FALSE	Activates brake interlock	The brake is required to go from neutral to drive. (Paver Assist disabled.)

## Auto Neutral for I-Shift AMT-F

Auto neutral is now available on vehicles equipped with GHG 2017 engines and the new generation I-Shift AMT-F. This feature is offered on the following Volvo I-Shift options:

- I-Shift (Standard)
- I-Shift for Severe Duty
- I-Shift with Crawler Gears

Auto neutral will put the I-Shift transmission into neutral when the parking brake is set. Once the park brake is released, the shifter will need to be placed in drive (D) for the transmission to go back into gear. Auto neutral improves jobsite safety for a variety of applications such as mixers where remote throttle is often utilized.

Auto neutral can be enabled via the parameter (P1NFD = True) setting in Premium Tech Tool (PTT). If parameter (P1NFD) is not visible in Premium Tech Tool contact Body Builder Support @ 877-770-7575.

## Supplier PTO/Pump Literature

Refer to the appropriate PTO/pump manufacturer's literature for all additional PTO/pump information, specifications, and installation procedures.

### Bezares USA

Contact Bezares at 888-663-1786 for PTO/pump literature or visit the following site:

- <http://pto-usa.com>

### Parker Chelsea

Contact Parker/Chelsea at 662-895-1011 for PTO/pump literature or visit the following site:

- [www.parker.com/chelsea](http://www.parker.com/chelsea)

### Muncie

Contact Muncie at 800-367-7867 for PTO/pump literature or visit the following site:

- <https://www.munciepower.com>

### Permco

Contact Permco at 800-626-2801 for PTO/pump literature or visit the following site:

- [www.permco.com](http://www.permco.com)



**V O L V O**

**Volvo Trucks North America**

<http://www.volvotrucks.com>