



Power Take-off (PTO)

This information provides specification for Power Take-off (PTO) applications in Volvo vehicles.

Note: We have attempted to cover as much information as possible. However, this information does not cover all the unique variations that a vehicle chassis may present. Note that illustrations are typical but may not reflect all the variations of assembly.

All data provided is based on information that was current at time of release. However, **this information is subject to change without notice.**

Please note that no part of this information may be reproduced, stored, or transmitted by any means without the express written permission of Volvo Trucks North America.

Contents:

- “General”, page 3
- “Abbreviations”, page 3
- “Power Take-off Types”, page 6
- “Rear Engine Power Take-off (REPTO)”, page 6
- “Transmission–mounted PTO”, page 8
- “PTO Installation Kits”, page 9
- “PTO Kit Part Numbers”, page 10
- “Dual PTO Specifications”, page 18
- “Transmission-driven PTO”, page 23
- “Power Take-off (PTO), Installation (I-Shift)”, page 24
- “Hydraulic Pumps”, page 34
- “Pump Types”, page 45
- “Delivery Conditions for Factory Installed Hydraulic Pumps”, page 46
- “PTO/Pump Power Requirements”, page 51
- “Supply and Pressure Lines”, page 54

- “Hydraulic Piston Pumps”, page 57
- “Hydraulic Wet Kits”, page 65
- “PTO Speed Functions”, page 71
- “Power Take-off Controls”, page 73
- “PTO Programming”, page 74
- “Power Take-off Worksheet”, page 77
- “Engine Speed Control”, page 78
- “Engine speed related parameters”, page 81
- “Engine Speed Control characteristics related to active PTO”, page 82
- “Regeneration in PTO Mode”, page 83
- “Auto Neutral for I-Shift AMT-G”, page 84
- “Supplier PTO/Pump Literature”, page 85

Overview

General

Auxiliary equipment requires power take-offs, either when the truck is stationary or when it is in motion. Various power take-off alternatives can be chosen, depending on the bodywork.

The work is generally carried out by equipment which is powered by a hydraulic motor. The hydraulic motor, together with a pump and associated equipment, form the basis of the hydraulic system. The pump, which provides the hydraulic pressure and flow to the motor, is the heart of the hydraulic system.

All power take-offs covered by this chapter are available factory installed. Some variants can also be ordered. It is important to design an optimum hydraulic system, and to specify the correct pump size to provide sufficient oil flow and prevent overloading of the power take-off.

Power Take-off

There are a number of different power take-off variants available, with single or double outlets. The power take-off is supplied with one of several output drives, keyed shaft, SAE drive flange or internal splined DIN.

Power take-offs are classified into two family variants: **Clutch dependent** and **Clutch independent**

Note: See Tool Tab in the Body Builder Portal for the Pump Speed Calculator.

Abbreviations

PTR	=	Single power take-off transmission, rear mounted (P ower take-off T ransmission R ear). All are rear-facing.
PTRD	=	Double power take-off transmission, rear mounted (P ower take-off T ransmission R ear mounted, D ouble)..
EPTT	=	Maximum permitted torque on engine power take-off (E ngine P ower T ake-off T orque).
HPE	=	Hydraulic pump mounted to an engine power take-off (H ydraulic P ump E ngine mounted).

PTO Speed Functions

For the purposes of this manual, PTO (Power Take-off) is a function to maintain engine speed regardless of engine load. Think of it as cruise control for the engine - only instead of maintaining a steady vehicle speed, it is maintaining engine speed. It is most often used to provide increased steady engine speed when operating auxiliary equipment such as hydraulic pumps or compressors. The term "PTO" has come to mean both the function of maintaining constant engine speed during use of auxiliary equipment, as well as a term for the auxiliary equipment itself.

There are two types of PTO engine speed control used in Volvo trucks:

Electronic Hand Throttle

(EHT/PTO 0) This type of PTO is standard equipment; it is initiated and controlled using the cruise control "ON/OFF", "SET / Decel or Resume / Accel switches. Manufacturers refer to this function by different names - Volvo calls it "Electronic Hand Throttle" (EHT), even though some of the parameters for programming this function will refer to it as "high idle". (Note that in the North American market, the term "high idle" usually refers to the maximum possible engine speed under no-load conditions).

"Physical" or "Wired" PTO This type of PTO is most commonly associated with the engagement of engine- or transmission- "Wired" PTO driven accessories, where the user wishes to "remotely" activate the engine speed control function. It is usually accomplished by wiring the auxiliary equipment to the PTO function controller (VMCU, BBM ECU, or Transmission ECU) so that engaging one will automatically activate the other.

Notes

PTO Functions with the D13 Engine

A "PTO" icon will appear in the instrument cluster only when 'Remote' ('Wired') PTO is engaged.

Electronic Hand Throttle PTO

The VMCU reads the cruise control PTO switch status, and commands the engine into PTO mode when conditions are right. These conditions are program in the VMCU and might include a maximum vehicle speed, park brake set or not, etc.

The engine PTO 'set speed' is selected by either pressing the cruise control "RES" button, or by using the accelerator pedal to get the desired engine speed and pressing one of the cruise control "SET" buttons (either SET+I or RES). Once the PTO function is active, the SET+ or RES- buttons can be used to adjust the PTO engine speed (within limits).

Physical or Remote/Wired PTO

This PTO function is activated by applying an external signal to a dedicated PTO input pin on the VMCU. The set speed can be adjusted using the cruise control SET+ or RES- buttons.

The Volvo VMCU allows for up to 4 PTO speed controls plus the PTO (EHT) without the use of a BBM. Each PTO can be independently selected and controlled by separate speed settings as well as independent engagement and disengagement requirements.

A sub-function of the 'wired' PTOs in the VMCU is the ability to activate PTO "outputs". Traditionally, the auxiliary device (PTO pump, bypass solenoid, etc.) is wired so as to be activated by the same switch which initiates the engine speed control function. This means that the hardware will be engaged whenever the switch is on, even if the engine speed is not being controlled. There also is no protection against an input switch that has been accidentally activated.

With the *I-SHIFT* transmission the PTO "Output Control" function of the VMCU and BBM ECU, it is possible to prevent engagement of the auxiliary equipment until certain conditions are met - park brake set, engine speed within a certain range, etc. This is accomplished by controlling the auxiliary equipment with the VMCU, instead of directly from a switch. The ECUs still read the switch input, though, and will only allow the auxiliary device to engage when conditions are right.

Notes

Power Take-off Types

Clutch Dependent Power Take-off

Clutch dependent power take-offs are designed to work when the truck is parked. Common applications are dump trucks, mobile cranes, tank trucks, etc. They are mounted on the transmission and stop working when the clutch pedal is depressed.

Note: The clutch pedal must be depressed (if equipped), to engage or disengage the power take-off.

- PTR-XX
- PTRD-XX

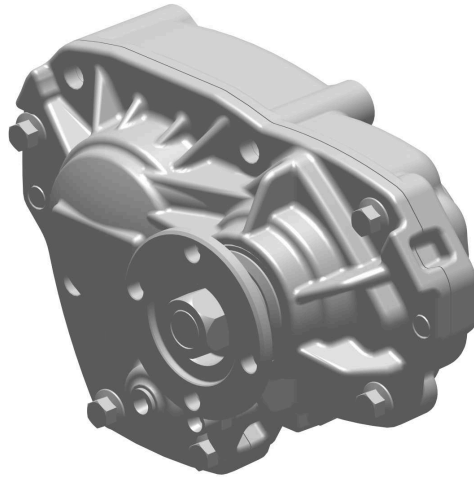

T4200028

PTR-FL

Clutch Independent Power Take-off

A clutch independent power take-off is mainly used when work is to be done when driving. Applications could include refrigerated, hook lifts, concrete mixer, snow plows/sand spreaders, etc. They are designed to be installed either on the front of the engine or rear of the timing cover.

Rear Engine Power Take-off (REPTO)

An engine mounted PTO is mounted on the rear of the flywheel housing.

D13 Engine

For the D13 engine, the PTO is ordered separately or when the vehicle is built.

The REPTO is applicable only for Regional truck models

- **PTER-DIN** (DIN5462/ISO7653 connection)
- **PTER1400** (flange SAE1400)
- **PTER-DIN + HPE-XXX**
(Engine PTO together with engine-mounted hydraulic pump)

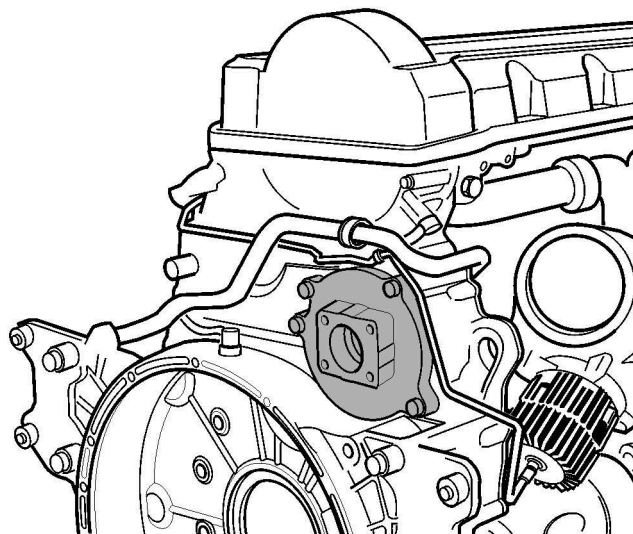

T9008395

PTER-DIN

Engine PTO in combination with I-shift

For vehicles with the *I-Shift* transmission, the **engine** PTO can be engaged during driving (depending on parameter setting) but the maximum torque must not exceed the predefined limit. Exceeding the maximum torque (as shown in the table below) can cause problems during gear shifting. For this reason, it is recommended that body equipment must be designed so that the torque limits in the table below are not exceeded during driving.

Engine	Direction of rotation	Engine PTO torque capacity	Maximum Torque Horsepower (Nm) While Driving
D13	Counter clockwise when facing back of engine	PTER-xxx + EPTT650	481 (650)
		PTER-xxx + EPTT1000	740 (1000)

Notes

I-Shift Power Take-off

The I-Shift is an automated manual transmission. When the PTO is engaged and if the Drive mode “D” is selected, the TECU commands the clutch to release and engage the countershaft brake. This stops the rotation of the countershaft and the PTO. When the driver releases the brake pedal and applies the throttle, the clutch re-engages and the PTO starts to rotate along with the countershaft.

When the driver stops the truck and if the reverse mode “R” is selected, the clutch disengages and reverse gear engages. When the reverse gear engages, the transmission-mounted PTO disengages. When the driver releases the service brake and applies the throttle, the clutch re-engages and the PTO engages and starts to rotate again.

If the driver wants to use the transmission-mounted PTO while moving the vehicle, the transmission will only be able to operate in the starting gear that was selected. Depending on the vehicle options and starting gear selected, the maximum vehicle speed is usually around 6 mph.

Transmission-mounted PTO

VOLVO I-Shift, AMT

This information is meant as an aid to identify transmission PTO options available with the I-Shift transmission.

The following table shows the available PTO's with installation kit part numbers. The installation kit includes the PTO and all necessary parts for the I-Shift Transmission.

PTO Type	Part Number PTO only	Part Number PTO with Installation Kit	Software Accessory Kit AMT-G
PTR-D	21027101	24950750 ¹	TBD
PTR-F	21027119	24950754 ¹	TBD
PTR-FL	20770442	24950755 ¹	TBD
PTR-DM	22770448	24950756 ¹	TBD
PTRD-F	21309308	24950763 ¹	TBD
PTRD-D	21309472	24950766 ^{1,2}	TBD
PTRD-D1	21309477	24950769 ^{1,2}	TBD
PTRD-D2	21309495	24950771 ^{1,2}	TBD
PTRD-D3	23283784	24950772 ^{1,2}	TBD
PTRD-D4	23283785	24950773 ^{1,2}	TBD

1 24964643 - Accessory kit for gearbox mounted PTO1. This is needed in addition to the PTO kit containing the PTO.

2 24964641 - Supplemental kit for gearbox mounted PTO2. This is needed in addition to the accessory kit (24964643), and the PTO kit.

To have pneumatic connections for PTO control, PTRD-D2, PTRD-D3 and PTRD-D4 require a separate valve kit, 23720743.

Notes

PTO Installation Kits

The following table outlines the installation kit necessary for installing PTO PTR-D, PTR-F, PTR-FL, PTR-DM, PTRD-F and PTRD-D on an I-Shift transmission. When installing the PTO, kit number is necessary.

Kit Part number	Kit Description	Part Number	Part Description	Quantity
24964643	Single PTO Truck Prep Kit	948211	cable tie, black	2
		25107341	Flange Screw	2
		995627	Plug Small	1
		24262391	Bracket Solenoid Mounting	1
		24145125	24V Solenoid Valve, Stackable	1
		23702125	Switch, Trans PTO1 Switch	1
		23616844	Nipple, 1/4" Small	2

The following table outlines the additional installation kit necessary for installing PTO PTRD-D1, PTRD-D2, PTRD-D3 and PTRD-D4 on an I-Shift transmission. When installing the PTO, kit number is necessary.

KIT Part number	Kit Description	Part Number	Part Description	Quantity
24964641	Dual PTO Truck Prep Kit Supplementary Kit (to be added as supplement to Single PTO Truck Prep Kit)	23702126	Switch, Trans PTO2 Switch	1
		24145125	24V Solenoid Valve, Stackable	1
		25107341	Flange Screw	2
		23616844	Nipple, 1/4" Small	1

The following table outlines the additional parts needed when adding an aftermarket vendor PTO:

Part Number	Part Description	Quantity
914472	Snap Ring, 46.19*50*2, DIN471 A50	2
24113820	Roller Bearing, NUP2210, ECNRJ/C3VB6381	1
23957929	Shaft, PTO AMT, SPO	1
994459	Flange Screw, M12*90, 12*1.75*90Y1000LCK	4
1655383	Needle Bearing, K30*35*13	1
11996	Gasket, M16 5/8UN*16*22	1
21479808	Nipple, M16x1.5 and M14x1.5	1
21417392	Lubricating Grease	1
8077358	Fitting, 6.4*M12x1.5	1
948211	cable tie, black	1

PTO Kit Part Numbers

KIT Part number	Kit Description	Part Number	Part Description	Quantity
24950750	Name: POWER TAKE-OFF KIT Demarcation: GEARBOX MTD Characteristics: PTR-D Rear PTO Trans, DIN-Conn Pump	21027101	Power Take Off, PTR-D Assembly	1
		914472	Snap Ring, 46.19*50*2, DIN471 A50	2
		24113820	Roller Bearing, NUP2210, ECNRJ/C3VB6381	1
		23957929	Shaft, PTO AMT, SPO	1
		994459	Flange Screw, M12*90, 12*1.75*90 Y1000 LCK	4
		1667966	Sleeve, Pump Connection	1
		984814	Flange Screw, M13*25, 12*1.75 10-9 Silver	1
		994879	Washer, 13*37*6 Steel	1
		994870	Washer, 13*24*2 Steel BLK	1
		914465	Snap Ring, 32.45*35*1.5	1
		965545	Bracket, 3*14.2*142*3	1
		8082135	Elbow Nipple, 6.2*M12X1.5	1
		948211	cable tie, black	1

KIT Part number	Kit Description	Part Number	Part Description	Quantity
24950754	Name: POWER TAKE-OFF KIT Demarcation: GEARBOX MTD Characteristics: PTR-F Rear PTO Trans, Flange, 100% Speed	21027119	Power Take Off, PTR-F Assembly	1
		914472	Snap Ring, 46.19*50*2, DIN471 A50	2
		24113820	Roller Bearing, NUP2210, ECNRJ/C3VB6381	1
		23957929	Shaft, PTO AMT, SPO	1
		994459	Flange Screw, M12*90, 12*1.75*90 Y1000 LCK	4
		965545	Bracket, 3*14.2*142*3	1
		8082135	Elbow Nipple, 6.2*M12X1.5	1
		948211	cable tie, black	1

KIT Part number	Kit Description	Part Number	Part Description	Quantity
24950755	Name: POWER TAKE-OFF KIT Demarcation: GEARBOX MTD Characteristics: PTR-FL Rear PTO Trans, Flange, Low Speed	22770442	Power Take Off, PTR-FL at URET, Rearmounted G.Box	1
		914472	Snap Ring, 46.19*50*2, DIN471 A50	2
		24113820	Roller Bearing, NUP2210, ECNRJ/C3VB6381	1
		23957929	Shaft, PTO AMT, SPO	1
		994459	Flange Screw, M12*90, 12*1.75*90 Y1000 LCK	4
		1655383	Needle Bearing, K30*35*13	1
		11996	Gasket, M16 5/8UN*16*22	1
		21479808	Nipple, M16X1.5 and M14X1.5	1
		21417392	Lubricating Grease	1
		8077358	Fitting, 6.4*M12X1.5	1
		948211	cable tie, black	1

KIT Part number	Kit Description	Part Number	Part Description	Quantity
24950756	Name: POWER TAKE-OFF KIT Demarcation: GEARBOX MTD Characteristics: PTR-DM Rear PTO Trans, DIN-Conn Pump, Medium Speed	22770448	Power Take Off, PTR-DM at URET, Rearmounted G.Box	1
		914472	Snap Ring, 46.19*50*2, DIN471 A50	2
		24113820	Roller Bearing, NUP2210, ECNRJ/C3VB6381	1
		23957929	Shaft, PTO AMT, SPO	1
		994459	Flange Screw, M12*90, 12*1.75*90 Y1000 LCK	4
		1655383	Needle Bearing, K30*35*13	1
		11996	Gasket, M16 5/8UN*16*22	1
		21479808	Nipple, M16X1.5 and M14X1.5	1
		21417392	Lubricating Grease	1
		8077358	Fitting, 6.4*M12X1.5	1
		948211	cable tie, black	1

KIT Part number	Kit Description	Part Number	Part Description	Quantity
24950763	Name: POWER TAKE-OFF KIT Demarcation: GEARBOX MTD Characteristics: PTRD-F Rear PTO Trans, Double RHS, 1 SAE Flange	21309308	Power Take Off, PTRD-F at URET, 730 NM	1
		914472	Snap Ring, 46.19*50*2, DIN471 A50	2
		24113820	Roller Bearing, NUP2210, ECNRJ/C3VB6381	1
		23957929	Shaft, PTO AMT, SPO	1
		994459	Flange Screw, M12*90, 12*1.75*90 Y1000 LCK	5
		1655383	Needle Bearing, K30*35*13	1
		11996	Gasket, M16 5/8UN*16*22	1
		963948	Nipple, M16 5/8UN*16*22	1
		21417392	Lubricating Grease	1
		8077358	Fitting, 6.4*M12X1.5	1
		948211	cable tie, black	1

KIT Part number	Kit Description	Part Number	Part Description	Quantity
24950766	Name: POWER TAKE-OFF KIT Demarcation: GEARBOX MTD Characteristics: PTRD-D Rear PTO Trans, Double RHS, 2 DIN-Conn Pump	21309472	Power Take Off, PTRD-D at URET, 730 NM	1
		914472	Snap Ring, 46.19*50*2, DIN471 A50	2
		24113820	Roller Bearing, NUP2210, ECNRJ/C3VB6381	1
		23957929	Shaft, PTO AMT, SPO	1
		994459	Flange Screw, M12*90, 12*1.75*90 Y1000 LCK	5
		1655383	Needle Bearing, K30*35*13	1
		11996	Gasket, M16 5/8UN*16*22	1
		963948	Nipple, M16 5/8UN*16*22	1
		21417392	Lubricating Grease	1
		8077358	Fitting, 6.4*M12X1.5	1
		948211	cable tie, black	1

KIT Part number	Kit Description	Part Number	Part Description	Quantity
24950769	Name: POWER TAKE-OFF KIT Demarcation: GEARBOX MTD Characteristics: PTRD-D1 Rear PTO Trans, Double RHS, 1 DIN-Conn Pump + 1 SAE Flange	21309477	Power Take Off, PTRD-D1 at URET, 730 NM	1
		914472	Snap Ring, 46.19*50*2, DIN471 A50	2
		24113820	Roller Bearing, NUP2210, ECNRJ/C3VB6381	1
		23957929	Shaft, PTO AMT, SPO	1
		994459	Flange Screw, M12*90, 12*1.75*90 Y1000 LCK	5
		1655383	Needle Bearing, K30*35*13	1
		11996	Gasket, M16 5/8UN*16*22	1
		963948	Nipple, M16 5/8UN*16*22	1
		21417392	Lubricating Grease	1
		8082135	Elbow Nipple, 6.2*M12X1.5	1
		8077358	Fitting, 6.4*M12X1.5	1
		948211	cable tie, black	2

KIT Part number	Kit Description	Part Number	Part Description	Quantity
24950771	Name: POWER TAKE-OFF KIT Demarcation: GEARBOX MTD Characteristics: PTRD-D2 Rear PTO Trans, Double RHS, 1 DIN-Conn Pump + 2 Flanges	21309495	Power Take Off, PTRD-D2 at URET, 730 NM	1
		914472	Snap Ring, 46.19*50*2, DIN471 A50	2
		24113820	Roller Bearing, NUP2210, ECNRJ/C3VB6381	1
		23957929	Shaft, PTO AMT, SPO	1
		994459	Flange Screw, M12*90, 12*1.75*90 Y1000 LCK	5
		1655383	Needle Bearing, K30*35*13	1
		11996	Gasket, M16 5/8UN*16*22	1
		963948	Nipple, M16 5/8UN*16*22	1
		21417392	Lubricating Grease	1
		965566	Bracket, 4*14.2*160*3	1
		948211	cable tie, black	1

KIT Part number	Kit Description	Part Number	Part Description	Quantity
24950772	Name: POWER TAKE-OFF KIT Demarcation: GEAR-BOX MTD Characteristics: PTRD-D3 Rear PTO Trans, Double, LHS and RHS, 2 DIN-Conn Pump	23283784	Power Take Off, PTRD-D3 For AT G-Box Rearmounted	1
		914472	Snap Ring, 46.19*50*2, DIN471 A50	2
		24113820	Roller Bearing, NUP2210, ECNRJ/C3VB6381	1
		23957929	Shaft, PTO AMT, SPO	1
		994459	Flange Screw, M12*90, 12*1.75*90 Y1000 LCK	5
		1655383	Needle Bearing, K30*35*13	1
		11996	Gasket, M16 5/8UN*16*22	1
		963948	Nipple, M16 5/8UN*16*22	1
		21417392	Lubricating Grease	1
		948211	cable tie, black	1

KIT Part number	Kit Description	Part Number	Part Description	Quantity
24950773	Name: POWER TAKE-OFF KIT Demarcation: GEAR-BOX MTD Characteristics: PTRD-D4 Rear PTO Trans, Double, LHS, 1 DIN-Conn Pump + RHS 1 SAE Flange w Contr	23283785	Power Take Off, PTRD-D4 For AT G-Box Rearmounted	1
		914472	Snap Ring, 46.19*50*2, DIN471 A50	2
		24113820	Roller Bearing, NUP2210, ECNRJ/C3VB6381	1
		23957929	Shaft, PTO AMT, SPO	1
		994459	Flange Screw, M12*90, 12*1.75*90 Y1000 LCK	5
		1655383	Needle Bearing, K30*35*13	1
		11996	Gasket, M16 5/8UN*16*22	1
		963948	Nipple, M16 5/8UN*16*22	1
		21417392	Lubricating Grease	1
		948211	cable tie, black	1

I-Shift Transmission Mounted PTOs

PTO	Connection		Direction of Rotation	Max. Horsepower (kW)	Max. Torque ft-lb (Nm)
	Type	Dimension			
Single					
PTR-FL	Flange	SAE1300	Counter clockwise (viewed from rear)	134 (100)	443 (600)
PTR-DM	Direct	DIN5462			
PTR-D	Direct	DIN5462	Clockwise (viewed from rear)	200 (150)	737 (1000)
PTR-F	Flange	SAE1410	Clockwise (viewed from rear)	200 (150)	737 (1000)
PTRD-F	Flange (Outer)	SAE1400	Clockwise (viewed from rear)	161 (120)	538 (730)
	Direct (Inner)	DIN5462	Counter clockwise (viewed from rear)		
PTRD-D	Direct (Front)	DIN5462	Counter clockwise (viewed from rear)		
	Direct (Rear)		Clockwise when facing back of engine		
PTRD-D1	Direct (Front)	DIN5462	Counter clockwise when facing front of engine		
	Flange (Rear)	SAE1400	Clockwise when facing back of engine		
PTRD-D2	Direct (Front)	DIN5462	Counter clockwise when facing front of engine	Max power inner and outer shafts must not exceed 161 hp (120)	Max Torque 738 ft-lb (1000). See table below.
	Flange (Outer)	SAE1300	Clockwise when facing back of engine		
	Flange (Inner)	SAE1400	Counter clockwise when facing back of engine		
PTRD-D3	Left-hand side: Direct	DIN5462 / ISO 7643	Counter clockwise when facing back of engine	95 kW (127.4 hp)	See "Dual PTO Specifications", page 18
	Right-hand side: Direct			125 kW (167.6 hp)	
PTRD-D4	Left-hand side: Direct	DIN5462 / ISO 7643	Counter clockwise when facing back of engine	95 kW (127.4 hp)	See "Dual PTO Specifications", page 18
	Right-hand side: Flange	SAE 1310/1410		125 kW (167.6 hp)	

Power Take-Off (PTRD-D2) Maximum Torque

642 ft-lb (850) Maximum PTO Torque for PTRD-D2	
Inner shaft ft-lb (Nm)	Outer shaft ft-lb (Nm) [sum of front and rear PTO]
738 (1000)	148 (200)
664 (900)	221 (300)
516 (700)	295 (400)
369 (500)	369 (500)
203 (275)	443 (600)
48 (65)	516 (700)

Speed Ratio for I-Shift Transmission Mounted PTOs

Engine Speed: Transmission PTO Ratio (Example – 1:1.65)

Power Take-off Type	Weight (lbs)	Overdrive		Direct	
		Low/Neutral-1	High/Neutral-2	Low/Neutral-1	High/Neutral-2
Single					
PTR-FL	35.3	0.93	1.18	0.73	0.93
PTR-DM	28.7	1.35	1.72	1.06	1.35
PTR-D	10	0.9	1.15	0.7	0.9
PTR-F	10	0.9	1.15	0.7	0.9
Double and Triple					
PTRD-F (Outer)	50.7	1.65	2.10	1.30	1.65
PTRD-F (Inner)		0.77	0.98	0.60	0.77
PTRD-D	50.7	1.65	2.10	1.30	1.65
PTRD-D1	62.8	1.65	2.10	1.30	1.65
PTRD-D2 (Outer)	76	1.65	2.10	1.30	1.65
PTRD-D2 (Inner)		0.77	0.98	0.60	0.77
PTRD-D3 (LHS)	58.6	0.76	0.97	0.60	0.76
PTRD-D3 (RHS)		1.29	1.64	1.01	1.29
PTRD-D4 (LHS)	70.3	0.76	0.97	0.60	0.76
PTRD-D4 (RHS)		1.29	1.64	1.01	1.29

Note: When the truck is stationary, use of crawler gears is not allowed to run the PTO.

Note: If the PTO operating condition exceeds 100 hp (75 kW) for 15 minutes, the PTO requires the oil cooler.

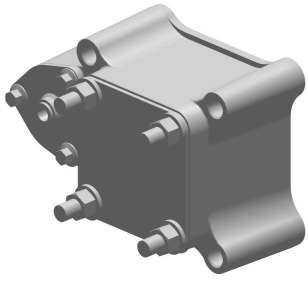

T4200029

PTR-D

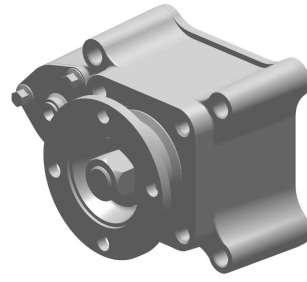

T4200030

PTR-F

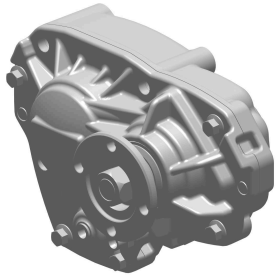

T4200028

PTR-FL

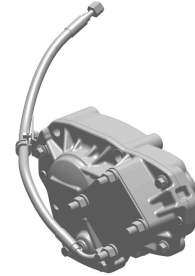

T4200031

PTR-DM

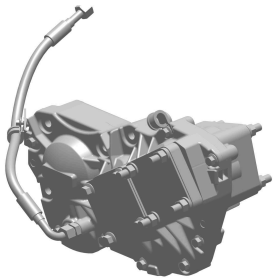

T4200032

PTRD-D

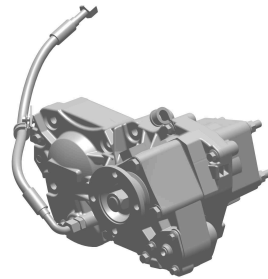

T4200033

PTRD-D1

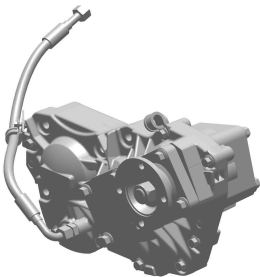

T4200037

PTRD-F

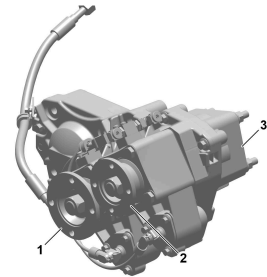

T4200034

PTRD-D2

PTO Drive Position on the Double and Triple PTO Housings

- 1 PTO # 1
- 2 PTO # 2

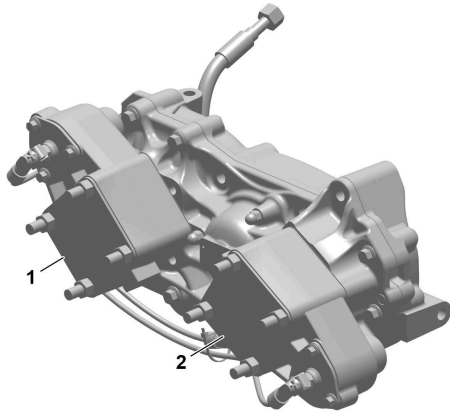

T4200035

PTRD-D3

- 1 DIN type PTO, LHS
- 2 DIN type PTO, RHS

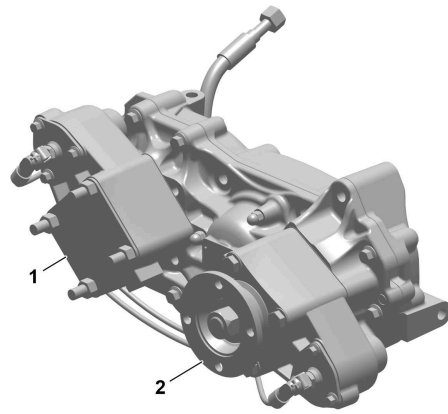

T4200036

PTRD-D4

PTO Drive Position on the Double

- 1 DIN type PTO, LHS
- 2 Flange type PTO, RHS

Dual PTO Specifications

PTRD-D3 / PTRD-D4		Left-hand side	Right-hand Side	
Output Torque (Nm)		0	800	
		170	700	
		340	600	
		510	500	
		680	400	
		850	300	
		920	260	
		1000	200	
		1000	100	
		1000	0	
Output Power		95 kW (127.4 hp)	125 kW (167.6 hp)	
Weight	PTRD-D3	26.6 kg (58.6 lb)		
	PTRD-D4	31.9 kg (70.3 lb)		
Additional oil added to the transmission (due to PTO installation)		1.1 liter (1.162 quart)		
Direction of rotation		Counterclockwise (same as engine rotation)		
Ratio (RPM Output : Input)		0.85 : 1	1.43 : 1	
Total Ratio (PTO RPM : Engine RPM)	Direct Drive (DD) Transmission	Low Shift	0.60 : 1	1.01 : 1
		High Shift	0.76 : 1	1.29 : 1
	Over Drive (OD) Transmission	Low Shift	0.76 : 1	1.29 : 1
		High Shift	0.97 : 1	1.64 : 1

Dual PTO Field Combinations

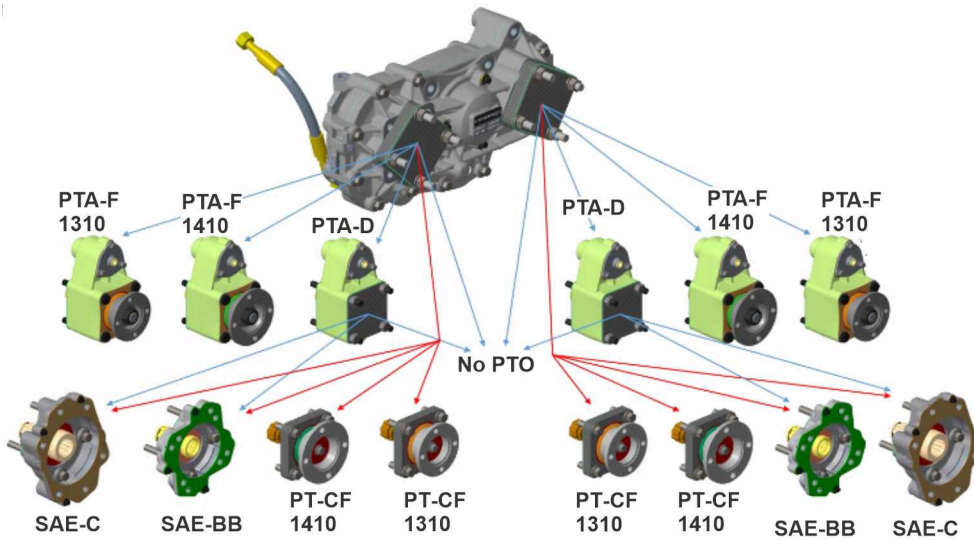

T4177369

Dual PTO	PTO type (left side)	PTO type (right side)	PTO Kit Part Number
PTRD-D3 / PTRD-D4	PTA-D ¹	PTA-D ¹	23283789
	PTA-F (SAE 1410)	PTA-F ¹ (SAE 1410)	23283788
	PTA-F (SAE 1310)	PTA-F (SAE 1310)	23283795
	SAE-C ²	SAE-C ²	23283787
	SAE-BB ²	SAE-BB ²	23283786
	PT-CF (SAE 1410)	PT-CF (SAE 1410)	23283790
	PT-CF (SAE 1310)	PT-CF (SAE 1310)	23283791

1 Factory fitted

2 It can be installed directly on the PTO housing or through the factory-installed PTA-D.

Dual PTO Pump Option

Dual PTO	Left-hand side PTO	Right-hand side PTO	Notes
PTRD-D3	F1 Series	F1 Series	—
	F1 Series	GP Series	—
	GP Series	F1 Series	—
	GP Series	GP Series	—
	—	F1 Series	Single pump specs always installed on right side. As needed, install an alternative output and/or reposition the pump to left side at field.
	—	GP Series	
PTRD-D4	F1 Series	PTA-F	—
	GP Series	PTA-F	—
	—	PTA-F	As needed, install an alternative output and/or reposition the pump to left side at field.

I-Shift Transmission Mounted PTO, Installation Notes

The PTO and engine speed control functions are mainly controlled by the VMCU. PTO settings such as entry and exit conditions, road speed limit and engine speed limits are controlled and configured in the VMCU.

PTO1 and PTO2 solenoids are activated by the Center Chassis Input/Output Module (CCIOM). To control the PTO1 and PTO2 solenoids, parameters must be set in the TechTool.

The Body Builder Module (BBM) allows for PTO requests via digital input on the chassis or CAN messages from Body Builder controllers via BBNet.

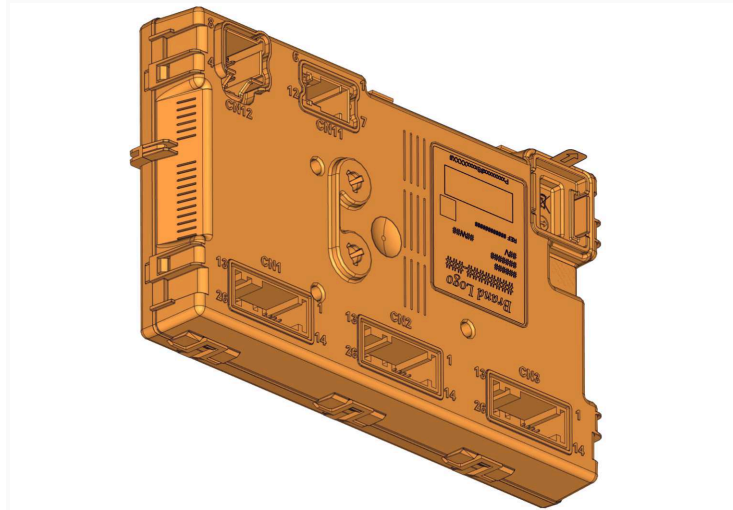

T3200555

VMCU

Note: VMCU will have 5 connectors.

Note: When installing an I-Shift transmission mounted PTO, contact Volvo Tech Support or Body Builder Support to secure the correct software for the Body Builder Module (BBM) as well as the Transmission Electronic Control Module (TECU).

Transmission Mounted Hydraulic Pump, Installation Notes

All pumps have a Right Hand direction of rotation as seen from the PTO looking to the front of the vehicle. If installing PTO PTR-DM or PTRD-D, a supply fitting and valve are necessary.

The following is information about applicable pumps and fittings:

Application Chart					
Parker Pump Options	Displacement cc/rev (cu.in/rev)	Flow @ 800 RPM L/min (GPM)	Flow @1000 RPM L/min (GPM)	Flow @ 1200 RPM L/min (GPM)	Flow @ 1600 RPM L/min (GPM)
F1-41	2.5 (40.9)	32.9 (8.7)	40.9 (10.8)	49.2 (13)	65.9 (17.4)
F1-61	3.6 (59.5)	48.8 (12.9)	60.9 (16.1)	73.4 (19.4)	97.7 (25.8)
F1-81	5.0 (81.6)	64.7 (17.1)	81 (21.4)	97.3 (25.7)	129.8 (34.3)
F1-101	6.3 (102.9)	14.4 (54.5)	101.1 (26.7)	121.5 (32.1)	162 (42.8)
F2-42/42	A port – 42 (2.6) B port – 42 (2.6)	34.1/34.1 (9/9)	41.6/41.6 (11/11)	49.2/49.2 (3/13)	68.1/68.1 (18/18)
F2-53/53	A port – 54 (3.3) B port – 52 (3.2)	41.6/41.6 (11/11)	53/53 (14/14)	64.4/64.4 (17/17)	83.3/83.3 (22/22)

Notes

Layout and Specifications

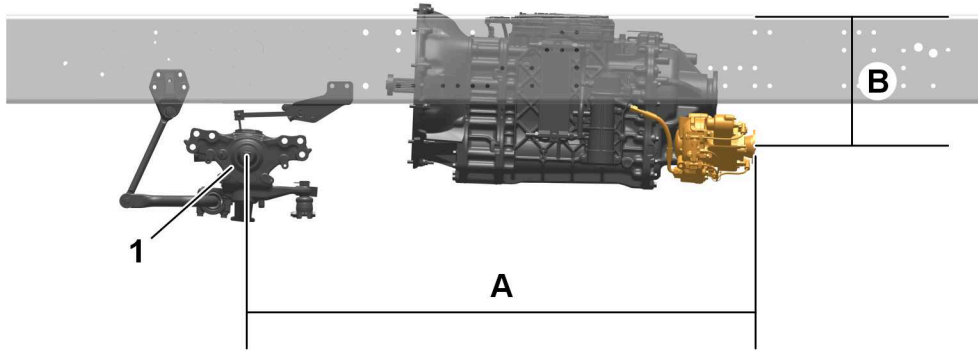

T4200038

I-Shift PTO Mounting Surface

1 Front Axle Centerline

			Transmission Model	
			AMT Direct	AMT Overdrive
Chassis	Engine	Crank Angle	A= AMT 12 Speed mm (inches)	B =Frame Rail to PTO mm (inches)
VNL	13L	2.5	1341 (52.8)	431 (17.0)

Transmission-driven PTO

The transmission-driven PTO is most suitable for trucks used where work is performed while stationary. An example are vehicles equipped with dump beds or hoists. The PTO is engaged by a switch on the instrument panel. A solenoid valve opens and releases compressed air to the PTO which, in turn, meshes with a gear in the transmission.

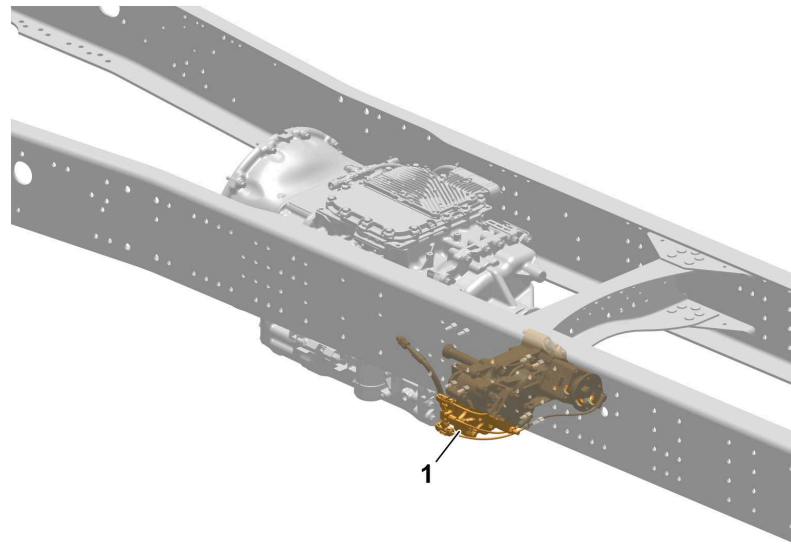

T4200039

Transmission-driven PTO

PTO Usage

The following illustration shows a number of typical applications and the power output requirement in hp (kW) and effective operational time (1) in hours used over a 5-year period. This illustrates the relationship between different body installations and the demands placed on the PTO.

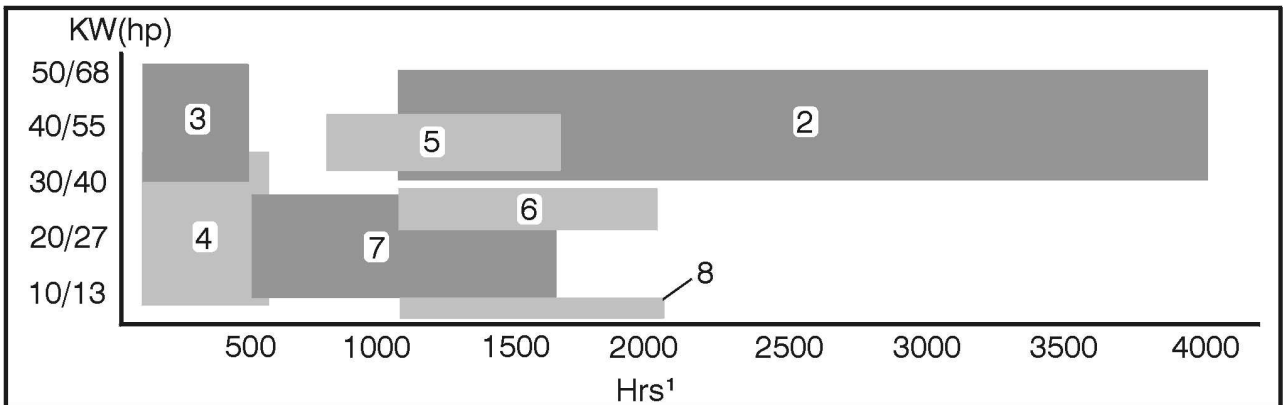

W4002383

In-power Requirements and Hours in Operation

- | | |
|--------------------------------------|------------------|
| 1. (Time used in hours over 5 years) | 5. Logging Crane |
| 2. Blowers | 6. Tank, Fuel |
| 3. Roll-off Body | 7. Crane |
| 4. Dump Truck | 8. Tank, Milk |

Power Take-off (PTO), Installation (I-Shift)

The PTO kit contains the PTO and all necessary components to install the PTO on the transmission. See page 8 . An additional single PTO kit (#24964643) is required and includes the PTO 1 switch, solenoid, bracket, and hardware. A dual PTO requires an additional kit (#24964641) that contains the PTO 2 switch, solenoid, and hardware.

The electrical directions contained in this bulletin only outline the component installation and setup needed to install a single solenoid driven PTO. If installing a PTO that utilizes two separate solenoids for actuation, more extensive electrical requirements will be necessary.

DANGER

Do not attempt to repair or service this vehicle without having sufficient training, the correct service literature and the proper tools. Failure to follow this could make the vehicle unsafe and lead to serious personal injury or death.

DANGER

Before working on a vehicle, set the parking brakes, place the transmission in neutral, and block the wheels. Failure to do so can result in unexpected vehicle movement and can cause serious personal injury or death.

DANGER

Before beginning any work on any part of the air system, be certain that the air pressure has been released. Failure to do so may cause a component to violently separate, which can result in serious personal injury or death.

1. Torque all fasteners using general tightening torque values unless specified in these instructions.

Fastener Size	ft-lb (Nm)
M6 standard bolt 8.8	7±1 (10±1)
M8 standard bolt 8.8	18±3 (24±4)
M10 standard bolt 8.8	35±6 (48±8)
M12 standard bolt 8.8	63±11 (85±15)
M14 standard bolt 8.8	103±18 (140±25)
M16 standard bolt 8.8	140±26 (190±35)

2. Raise and support the rear of the vehicle.

Note: Lift the rear of the truck until the back of the transmission has been raised 76-89 mm (3-3.5 in) to minimize transmission fluid loss.

3. Drain the air system.

4. Drain the I-Shift transmission air supply tank.

Note: This tank is equipped with a pressure protection safety valve and will not drain with the rest of the air system.

5. Remove the PTO mounting surface block off plate from the transmission range housing.

Note: Position a drain pan to capture lost transmission fluid.

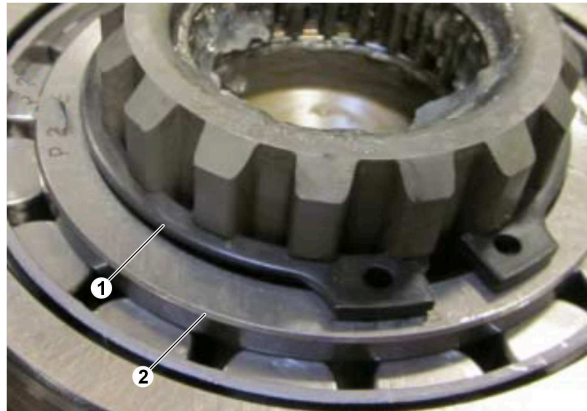

T4204761

1 Snap Ring

2 Thrust Washer

6. Assemble the PTO drive shaft assembly using the PTO drive shaft, bearing, thrust washer and two snap rings.

Note: Position one snap ring under the bearing and the other snap ring (1) on top of the thrust washer (2).

Note: Using a brass drift, gently drive the bearing into place striking only the inner race. Reposition the drift with each strike, rotating around the bearing.

Notes

7. Pack the PTO drive shaft bearing with grease. **Note:** Use a synthetic based grease such as VOLVO part number 1077790 or equivalent.

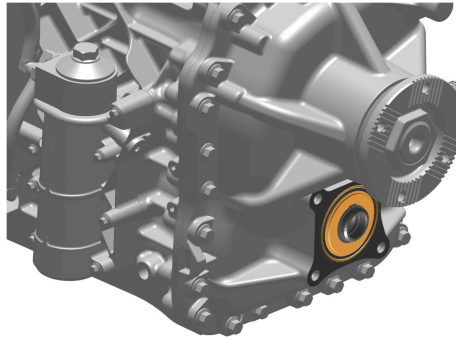

T4200582

8. Install the PTO drive shaft assembly in the transmission.

Note: Once positioned in the transmission, it may be necessary to gently tap the shaft in. Use a plastic or rubber faced hammer.

Note: The bearing is seated when the snap ring on the outside of the bearing touches the mating groove on the transmission.

9. Lubricate the PTO drive shaft pilot bearing.

Note: Use a synthetic based grease such as VOLVO part number 1077790 or equivalent.

10. Install the PTO drive shaft pilot bearing.

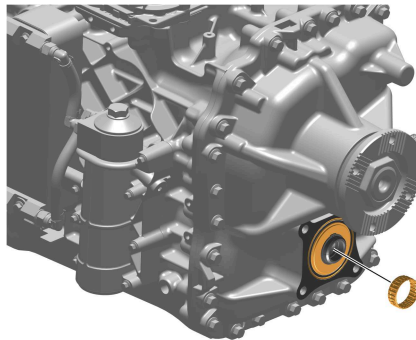

T4200581

11. Clean the PTO mating surface on the transmission, and then apply a bead of silicone sealant.

Note: Only use silicone to seal the PTO mating surfaces. Do not use gaskets or O-rings.

12. Install the air line bracket on the left upper PTO mounting bolt. Install the PTO and tighten the mounting bolts (1) to 85 ± 5 (30 ± 4 ft-lb).

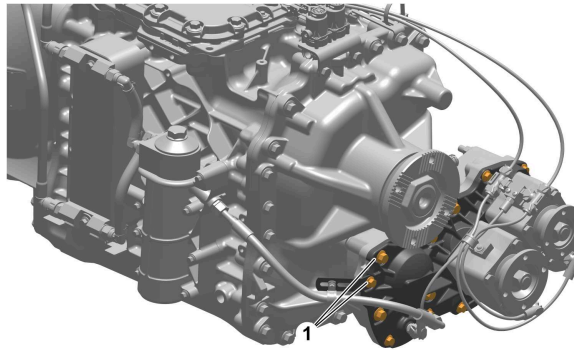

T4200041

13. Remove the PTO oil supply line plug from the back side of the transmission oil filter housing.

14. Install the oil feed line fitting into the port on the back side of the transmission oil filter housing. Torque the fitting.

Note: Use a copper gasket to seal the fitting

15. Connect the PTO oil feed line to the oil port. Torque the line (1) to 40 ± 3 Nm (29.5 ± 2.2 ft-lb).

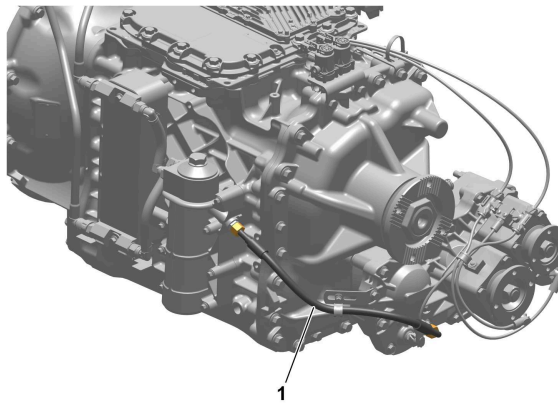

T4200042

16. Locate the PTO solenoid wiring harness connectors tied to the transmission wiring harness on top of the transmission. Cut tie straps as needed to free the harness for use.

Note: The wiring tags should read PTO1 and PTO2 at the connectors.

17. For a single PTO, install two quick connect air fittings and one pipe plug into the PTO solenoid. For dual PTOs, install an O-ring between the solenoids in place of the pipe plug.

Note: The supply line fitting should accept a 9.5 mm (3/8 in) air line, and the outlet fitting should accept a 6.35 mm (1/4 in) air line.

Note: Refer to "Section 5 - Air Brake System Schematics and Routing" of the body builder manual for fitting #991973 and the service tools needed.

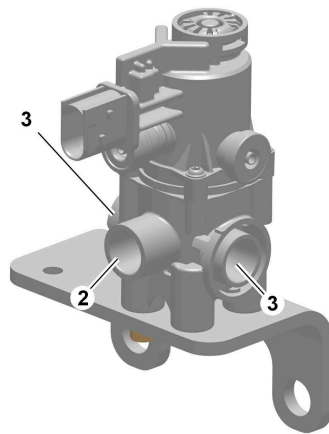

T4205980

- 1 Plug for single or O-ring for dual
- 2 Outlet fitting 1/4"
- 3 supply line 3/8"

18. Install the PTO solenoid to the bracket and torque the bolts (1) to 10 ± 1.5 Nm (7.3 ± 1.10 in-lb).

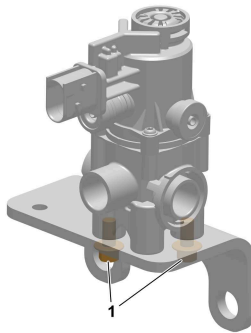

T4200045

19. Remove the two, top left range housing mounting bolts.

20. Install the PTO solenoid bracket using the range housing bolts. Torque the bolts (1) to 105 ± 7 Nm (77.4 ± 5.1 ft-lb).

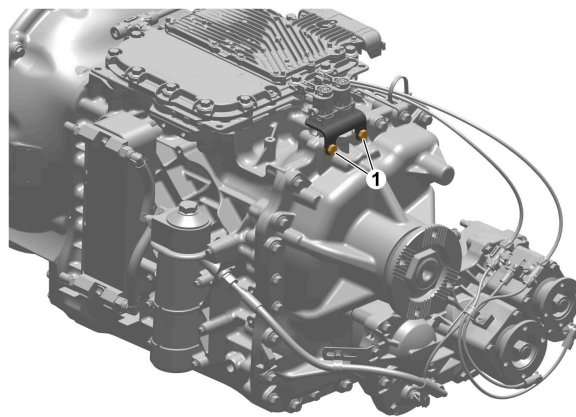

T4200043

21. Connect PTO1 wiring harness to the solenoid.

Note: The wiring tags should read PTO1 and PTO2 at the connectors.

22. Install a 90° air line quick connect fitting into the PTO.

Note: The fitting should accept a 6.35 mm (1/4 in) air line.

23. Install a 6.35 mm (1/4 in) inch air line from the solenoid to the PTO.

Note: Route the air line away from the moving parts and secure to the mounting bracket with tie straps.

24. Remove the plug from the available 9.5 mm (3/8 in) inch air line port on the pressure protection manifold, found on the left inner frame rail.

25. Install the solenoids. Install the 9.5 mm (3/8 in) air supply line to the pressure protection manifold and then connect it to the solenoid.

Note: Route the air line away from any moving parts and secure using tie straps.

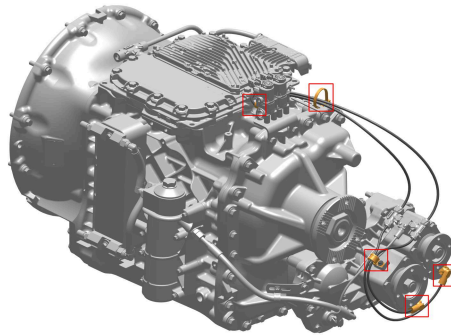

T4200048

Notes

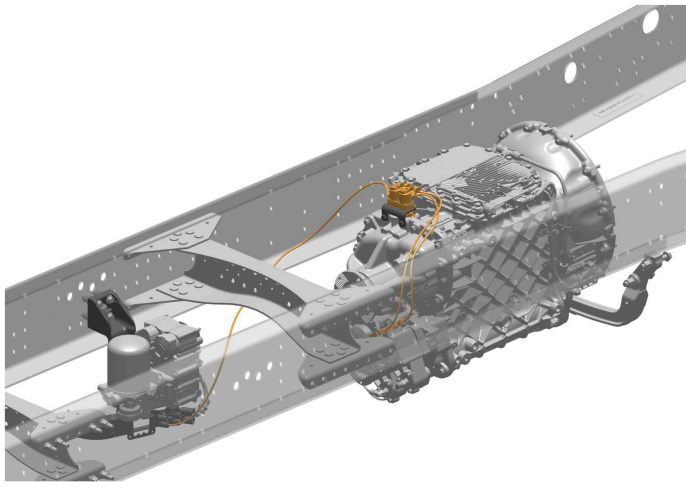

T4200044

26. Remove the plug from the available 3/8-inch air line port on the pressure protection manifold (found on the left inner frame rail). Insert the air line and route it to the solenoid inlet 3/8 port.

27. Pressurize the air system and check for leaks.

Note: If any leaks are found, drain the air tank and repair the leak. Re-test until no leaks are found.

28. Remove the supports and lower the vehicle.

29. Should the transmission require additional oil see charts below.

Park the vehicle on a level surface and check the transmission oil level through the sight glass on the right side of the transmission. Add Volvo-approved synthetic transmission oil as needed. Note that the drain plug indicates the type of oil used in the transmission.

Silver Drain Plug	85146530, SAE50 I-Shift Heavy Duty
Brass Drain Plug	VPO120549, 75W-80 I-Shift Standard

Volvo Oil Types and Part Numbers

Oil Weight	Part Number and Alternative
SAE50	85146530 or Mobile Delvac Synthetic Transmission Oil V50
75W-80	VPO120549 or Mobile Delvac Synthetic Transmission Oil V30

Note: Fill the transmission until the fluid level is between minimum and maximum of the sight glass.

Note: Do not reuse old oil from the I-Shift transmission. Always use new oil when filling.

Note: 1–2 L (1–2.1 qt) of fluid may be lost during the installation.

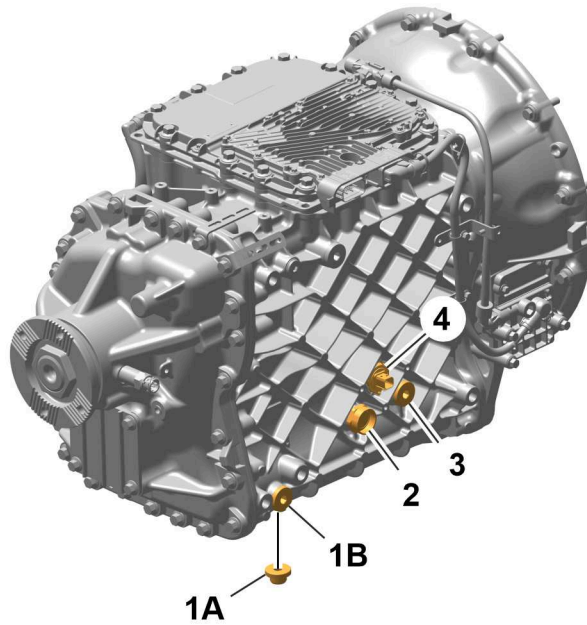

T2196749

- 1A. Drain plug
- 1B. Drain port
- 2. Sight glass
- 3. Fill plug and oil level
- 4. Oil level sensor

Notes

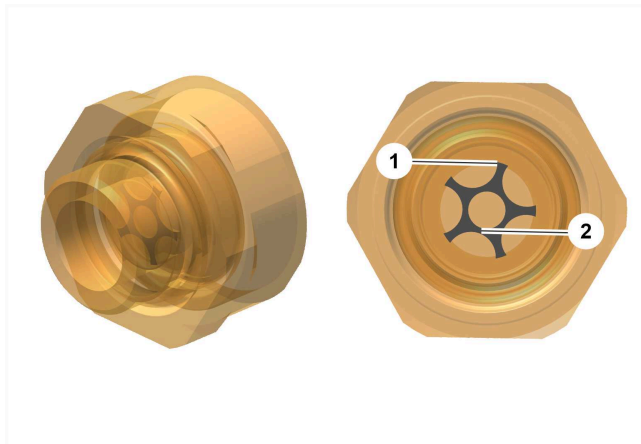

T2196750

- 1. Max oil level
- 2. Min oil level

30. The PTO switch connector is in the cab wiring harness and should be located in general area (A).

Note: If the switches on the Area 1 (A) are filled, the switches are moved to the Area 3 (D) based on the priority

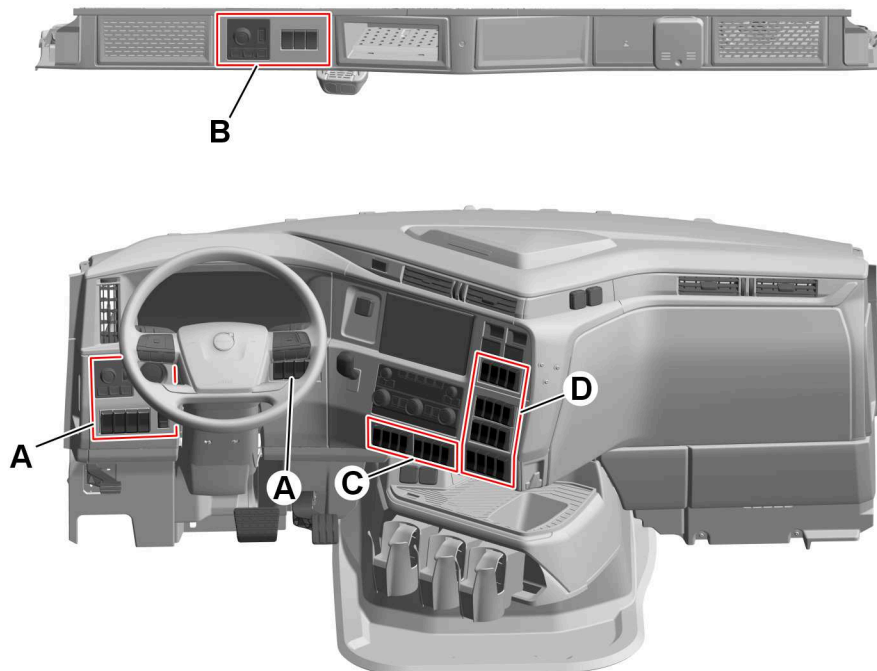

T3199020

31. If spots are not available, another flexible switch panels with wiring may be needed. Once switches are added, switch calibration must be run using operation number: 3646-07-03-02.

Note: Switch calibration and Guided Parameter Programming operation must be performed only for newly fitted switches. Factory-fitted switches do not require these operations.

32. Using the scan tool, flash the transmission control module (TCM) with the appropriate software for a single PTO. Contact the body builder support “877-893-3007” for further assistance.

Note: The appropriate software is dependent upon how many solenoids are being used to actuate the PTO (single or dual solenoids), not the outputs on the PTO.

32. After the TCM has been flashed with its software, it is necessary to perform the “Transmission and Clutch Calibration” using the scan tool.

34. Perform PTO parameter programming. For more information, refer to the “PTO Programming”, page 74 ” bulletin found in this Body Builders Manual.

35. Run the vehicle and re-check the transmission fluid level. Top up the transmission as needed so the fluid level is between minimum and maximum of the sight glass.

Note: The PTO shares the transmission fluid for lubrication. The PTO will retain about .75 liters (.8 qts.), of transmission fluid after initially being run. Always top up the transmission fluid after installing a new PTO.

Notes

Hydraulic Pumps

Abbreviations

HPE = Hydraulic pump mounted to an engine power take-off (**H**ydraulic **P**ump **E**ngine mounted).

HPG = Hydraulic pump mounted to a gearbox power take-off (**H**ydraulic **P**ump **G**earbox mounted).

Pump Connection

There are two types of connections for hydraulic pumps:

- Din Drive pumps
- Flange mounted

Din Drive Pumps

Plugged-in pumps are connected directly to the power take-off via a splined shaft. Connection is done according to DIN5462/ISO 7653 standard 8 X 32 X 36 mm spline shaft.

The VP1- and F1 Plus pumps are available for plugged-in mounting.

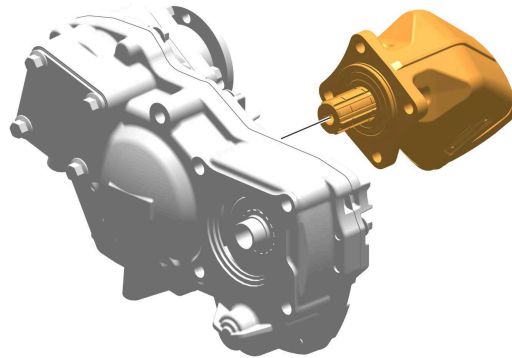

T9185395

Din mount

Flange Mounted Pumps

The hydraulic pumps can also be connected to the power take-off via a propeller shaft. Connection is done to a flange according to SAE 1300 or SAE 1400 standard.

The VP1- and F1 Plus pumps are possible to connect to a propeller shaft.

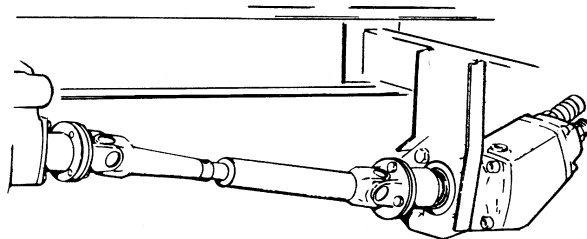

T9006112

Flange mounted

Hydraulic System and Pumps

Dimensioning of Hydraulic System and Hydraulic Pumps

Note: The body builder should enclose an information binder, delivered with the truck, including **hydraulic system data** (system dimensioning description and dimensioning criteria). Service, function and safety descriptions should also be enclosed.

It is the sole responsibility of the hydraulic system installer to follow all pump manufacturers guidelines for hydraulic system installation.



CAUTION

Volvo Trucks only supplies the information below as a guideline from the pump manufacturer and is not responsible for any mis-information in this section.

Pipes, Lines and Hoses



DANGER

Hoses and pipes should not be routed too near the warm points in the truck. Avoid crossed pipes which could cause chafing. Failure to follow this guide line increases the risk of fire if leakage occurs, and allows undue heat transfer to the hydraulic oil.

Connected to the hydraulic pump are a high-pressure hose, supply and drain lines.

When dimensioning the hydraulic system, it is important that:

- Hoses and lines must be connected to the pump with unions. O-ring seals must be used between pump and union.
- Tapered fittings should be avoided.
- Teflon tape or similar must not be used since pieces can break off and get into the hydraulic system and eventually cause damage.
- If steel piping is used, it must be installed so that movements and vibrations do not cause leakage. Normally hoses must be used nearest the pump.
- Oxide scale must be removed from pipes which have been heat-bent or welded. Flush or blow the pipes clean before installing them.

High-Pressure Hose

These hoses must have a minimum of four steel wire coil inserts in order to withstand the high pressure in the hydraulic system.

When mounting a high-pressure hose:

- Make sure the hoses are not twisted when connected up.
- Make sure the hoses are long enough.
- Strive to get as few bends as possible on a hose.
- Avoid kinks by using correct unions. Only pressed unions may be used when replacing hose unions.

Note: Check for oil leakage and for high noise levels in the system when the truck is in motion.

Supply Line

The supply line is made of piping or armored hose which retains its shape even when there is vacuum in the line.

To avoid cavitation:

- The supply line should be as short as possible and **should not exceed 4 meters (13.12 ft.)**. In the event longer lines are required, larger line dimensions must be used.
- The supply line should connect to the bottom of the tank and must be correctly tightened to prevent air getting into the oil.
- The supply line must have a wide diameter and must be free from kinks and constrictions. Do not use reducer fittings with restrictions.

Note: Avoid supply lines of high-pressure hooks and hooks made locally from pipe pieces welded together. They could cause unnecessary supply resistance.

Suitable supply line sizes at different flow quantities and with a flow speed of less than 0,8 m/s:

Inner diameter Ø mm (inches)	Flow up to liter/minute (gallons/minute)
50 (2.0)	0–120 (0–32)
64 (2.5)	101–150 (27–40)
75 (3.0)	> 150 (40)

Drain Line and Bypass Valve

If the hydraulic pump is installed to a constantly running PTO (i.e. — engine PTO), it is provided with a bypass valve.

The bypass valve reduces the oil flow through the pump to obtain proper lubrication, low heat generation and to avoid cavitation.

Fixed Displacement Pump

HPE-FXX (F1 single flow)

In order to prevent heat build-up in the pump during transportation, it is important that at least 5 liter/minute (1.32 gallons/minute) comes out of the filter at “q” (refer to the schematic below). This applies to an “open center” system when the valve is in the bypass mode (non-activated solenoid).

Note: If the flow at “q” is less than 5 liter/minute (5.28 quarts/minute) (caused e.g. by a high pressure drop in the main system) when the valve is in the bypass mode or if the hydraulic system is of the “closed center” type, then an external drain line **must be installed** from the bypass valve drain port directly to the hydraulic tank.

HPE-TXX (F2 twin flow)

In order to secure a cooling flow through the system, a separate drain line is already connected to the bypass valve from factory and the other end of the hose is temporary plugged. At final assembly the hose should be connected to the hydraulic tank, entering below oil level (preferable to the filter housing on the oil tank).

Bypass Valve

For the fixed displacement hydraulic pumps, the bypass valve is attached directly on top of the end cap of the hydraulic pump. It is electrical operated and the valve function must only be activated or released at no-load (below 20 bar) system pressure.

For F2- twin flow hydraulic pump it can be used when, temporarily, one of the two circuits is not required; the power loss is thus reduced as the non-required flow is not forced through lines and "open center" valves.

- 1 Pilot operated check valve
- 2 Solenoid valve
- 3 Directional control valve ("open center")
- 4 Hydraulic pump
- 5 Valve block
- 6 Drain port
- 7 (External line)

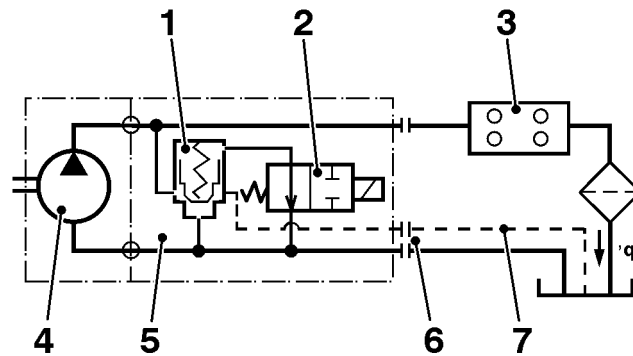

T9008080

HPE-FXX

Notes

Variable Displacement Pump

HPE-VXX (VP1)

At final assembly, since the control valve on the hydraulic pump is not internally drained, there must be an external drain line installed between port "T" and the hydraulic tank.

Bypass Valve

For variable displacement pump, the bypass is, from factory, attached to the temporary oil reservoir and connected to the hydraulic pump via a hose to the port for gauge outlet (VP1-75 port beside supply port).

The valve, which requires no additional control valve, allows the pump to operate on- or off-load up to its maximum self-priming speed.

When a load sensing valve function is engaged, the bypass flow is cut off (as port 'X' is being pressurized).

- 1 Hydraulic pump
- 2 Nipple with orifice
- 3 Bypass valve
- 4 Load sensing valve
- 5 Load sensing (LS) signal

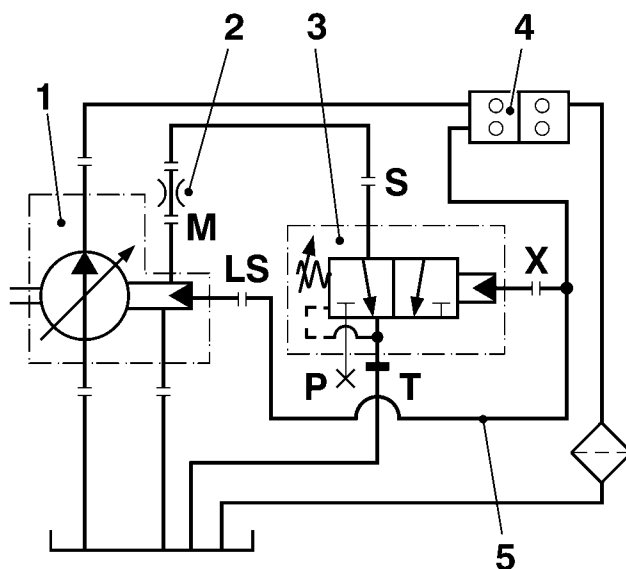

W4003014

HPE-V75

Return Oil Filter

Note: The filter must be replaced at least once a year.

A return oil filter should be installed in the tank or in the return line. The filter should be dimensioned for a capacity which is approximately twice that of the pump flow.

Recommended filtration level:

- A 28 micron filter should be used with lower pressures of 0–200 bar (0–2900 psi).
- A 10 micron filter should be used with higher pressures of 200–300 bar (2900–4351 psi).

Check return pipe and filter condition and check for oil leakage.

Hydraulic Oil

Note: Do not mix oils of different quality.

Hydraulic fluids type HLP (DIN51524), automatic transmission fluid (ATF) Dextron II and engine oil type API/CD can be used.

Recommended viscosity:

- 20-30 mm²/s (.78–1.18 inches²/s) (cSt) .

Starting Up



CAUTION

Make sure the supply connector always is below the minimum level of the hydraulic oil. Failure to do so may result in component damage.

Make sure the entire hydraulic system is clean before filling it with a recommended fluid. In particular the pump, which must be purged to remove any entrapped air in the pump housing (use the uppermost purge port). Failure to do so may result in component damage.

Notes

Calculation of Hydraulic Pump Size

The following information is required to dimension the hydraulic system:

- Oil flow $Q=l/\text{min}$ (Quarts/min.), to the equipment
- Oil pressure $p=\text{bar}$ (psi), to do the work intended
- Permissible torque or power taken from the engine
- Permissible pump speed
- PTO Gear ratio

Control the pump environment with the **Parker** calculation program.

Go to **Introduction** on the VBI homepage, choose **Software requirement** and click on **Parker**.

Engine Speed Control

Check that the permissible speed, specified by the pump manufacturer on the pump, is not exceeded.

Pump speed per minute n is governed by engine speed ne and power take-off gear ratio Z :

$$n = ne \times Z$$

n = Pump speed (rpm)

ne = Engine speed (rpm)

Z = Power take-off gear ratio

Pump Speed

The maximum (self-supply) speeds given in the catalogue apply at 1.0 bar (14.5 psi) (abs.) intake pressure.

To achieve correct pump speed the following is required:

- Oil level approx. 0.5 m above pump inlet
- Correctly dimensioned supply pipe
- Original supply nipple
- Correctly designed hydraulic fluid reservoir

The flow speed in the supply pipes should be less than **1 m/s (39.36 in/hg)**. Poor supply conditions lead to cavitation, high noise levels, shorter operational lifetime and, in the worst case, pump failure.

Pump Capacity

The pump capacity or size **D** cm³/rotation (inches³/rotation) should be able to give sufficient oil flow **Q** l/min (inches³/min.) for the equipment. The choice of size depends on the oil flow required, engine speed and power take-off gearing. A small pump can give a large oil flow if the power take-off gear ratio is large, or if the engine speed is high.

Pump size is calculated as:

$$Q = \frac{D \times n \times \eta v}{1000} \Leftrightarrow D = \frac{Q \times 1000}{n \times \eta v}$$

n = Pump speed (ne x Z)

D = Pump size cm³/rotation (inches³/rotation)

ne = Engine speed

Q = Oil flow l/min (quarts/min.)

Z = Power take-off gear ratio

ηv = volumetric efficiency

Torque Control

A certain torque, **Mku** is required from the power take-off at the pump shaft to drive the pump. This torque must not exceed the permissible torque for the power take-off. Expressed in Nm, this torque is:

$$M_{ku} = \frac{D \times p}{63 \times \eta hm} < M_{ku, till.}$$

Mku = Torque at power take-off (Nm)

D = Pump size cm³/rotation (inches³/rotation)

p = Hydraulic working pressure bar (psi)

Mku, till. = Permissible torque for the power take-off Nm (ft-lb)

ηhm = Mechanical efficiency

< = Less than

Torque Control, Engine

Torque control of the engine **Mmot** must not exceed the permissible torque for the engine (please refer to Body builder instructions "Power take-off, performance") at a given engine speed.

Engine torque is equal to power take-off torque x gear ratio.

$$M_{mot} = M_{ku} \times Z < M_{mot, till.}$$

Mmot = Engine torque Nm (ft-lb)

Z = Power take-off gear ratio

Mku = Torque at power take-off Nm (ft-lb)

Mmot, till. = Permissible engine torque Nm (ft-lb)

< = Less than

Power Requirements

The power **N** needed to drive the pump is proportional to the flow and working pressure and inversely proportional to the efficiency of the pump η .

Check that pump power curve, to see that it has the capacity needed to provide the calculated power **N**.

$$N = \frac{Q \times P}{600 \times \eta_t}$$

N = Power kW (hp)

Q = Flow through pump l/min (quarts/min.)

p = Working pressure bar (psi)

η_t = Overall pump efficiency(**app. 0.95**)

$\eta_t = \eta_v \times \eta_h$.

Notes

Example 1 (Dump), Selecting Pump Size Clutch Dependent PTO

Operating conditions

Flow	60-80 l/min (63–85 quarts/min.)
Pressure:	230 bar (3335 psi)
Engine rpm:	800 rpm
PTO ratio:	1:1.53

Determine the Pump Speed

$$n = n_e \times Z = 800 \times 1.53 = 1200 \text{ rpm}$$

Choosing the pump size

$$Q = \frac{D \times n \times \eta_v}{1000} \quad D = \frac{Q \times 1000}{n \times \eta_v} \quad \frac{70 \times 1000}{1200 \times 0,98} = 60 \text{ cm}^3/\text{rotation}$$

Select F1-61 and check torque and power.

Torque Requirement of the Pump

$$M_{ku} = \frac{D \times p}{63 \times \eta_{hm}} = \frac{59,5 \times 230}{63 \times 0,98} = 222 \text{ Nm}$$

Power Requirement of the Pump

$$N = \frac{Q \times p}{600 \times \eta_t} = \frac{70 \times 230}{600 \times 0,95} = 28 \text{ kW}$$

Notes

Example 2 (General Crane), Selecting Pump Size Clutch Independent PTO

Operating conditions

Flow	80 l/min (84 quarts/min.)
Pressure:	250 bar (3626 psi)
Engine rpm:	800 - 900 rpm
PTO ratio:	1:0.97

Determine the Pump Speed

$$n = n_e \times Z = 800 \times 0,97 = 800 \text{ rpm}$$

Choosing the Pump Size

$$Q = \frac{D \times n \times \eta_v}{1000} \quad D = \frac{Q \times 1000}{n \times \eta_v} \quad \frac{80 \times 1000}{800 \times 0,98} = 102 \text{ cm}^3 / \text{rotation}$$

Select F1-101 and check torque and power.

Torque Requirement of the Pump

$$M = \frac{D \times p}{63 \times \eta_{hm}} = \frac{102,9 \times 250}{63 \times 0,98} = 417 \text{ Nm}$$

Power Requirement of the Pump

$$N = \frac{Q \times p}{600 \times \eta_t} = \frac{102 \times 250}{600 \times 0,95} = 45 \text{ kW}$$

Notes

Pump Types

The following pump types are available from VOLVO:

- Pumps with fixed displacement
- Pumps with variable displacement

Fixed Displacement Pump

This type of hydraulic pump is adapted for a single circuit system with fixed volume.

The fixed displacement pump consists internally of one or two single circuit(s), from the supply port to the pressure port(s).

Examples:

- HPE / HPG-F61 (Parker F1-61)
- HPE / HPG-F81 (Parker F1-81)
- HPE / HPG-F101 (Parker F1-101)
- HPE-T53 (Parker F2-53/53)
- HPE-T42 (Parker F2-42/42)

Variable Displacement Pump

This type of hydraulic pump is also adapted for a single circuit system, from the supply port to the pressure port, but with variable displacement. When installed in a load sensing system, the variable displacement pump (VP1) supplies the correct amount of flow required by the various work functions currently engaged. This means that the energy consumption and heat generated are minimized and much reduced in comparison with a fixed displacement pump used in the same system.

Examples:

- HPE / HPG-V75 (Parker VP1-75)

Notes

Delivery Conditions for Factory Installed Hydraulic Pumps



CAUTION

Hydraulic pumps must never be in use without oil flow in the hydraulic system. Failure to do so may result in component damage.

For Trucks with Transmission Mounted PTO:

To prevent the possibility to engage the hydraulic pump before definitive assembly, the following is done from factory:

- The PTO magnetic valve outlet is blocked up by a hexagon socket plug.
One or two valves is plugged, depending on type of PTO.
- The valve nipple, which the body builder should connect, is placed in a plastic bag and strapped on the end of the pneumatic hose at magnetic valve

Permissible Pump Bending Torque

The hydraulic pump mounted to a power take-off causes bending torque at the power take-off.

A transmission mounted power take-off has the following maximum permissible torque:

PTR / PTRD with AMT-G Transmission

PTO	Maximum bending torque ft-lb (Nm)
PTR / PTRD	30 (40)

Calculation of Pump Bending Torque

Torque is calculated with the formula below:

$$M_b = m \times g \times A$$

M_b Bending moment at pump connection to power take-off (Nm).

m Pump weight (kg).

g Normal acceleration = 9.81 N/kg.

A Distance between pump center of gravity and anchorage on power take-off (m).

Note: This calculation method is used irrespective of PTO/pump location.

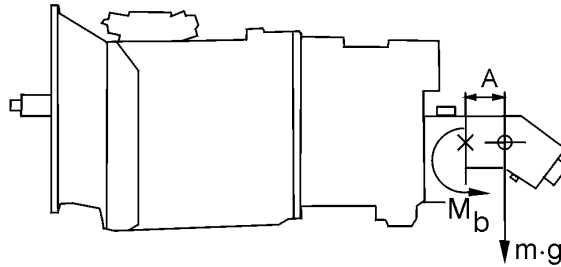

T9007591

Notes

Propeller Shaft Installation

If a power take-off with coupling flange is to be used, the pump is installed by means of a bracket, either on an existing cross-member or on the sub-frame. An alternative method is to install an extra crossmember and install the pump on it. In this case, it is important to design the crossmember so that it can withstand the forces involved when the chassis twists and bends. The best way to achieve this is to design the crossmember as a normal, intermediate crossmember.

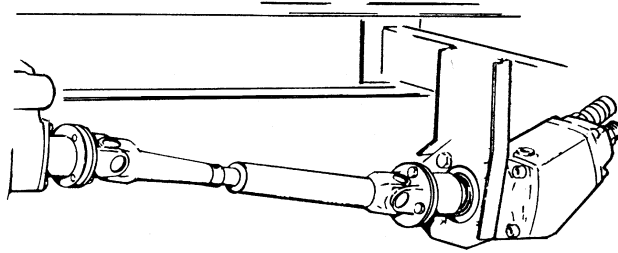

T9006112

The same requirements apply to power take-off propeller shafts as for drive line propeller shafts. For best service life, the true joint angle should be kept between 0.5 – 8 degrees.

It is important that angles $\beta 1$ and $\beta 2$ are equal.

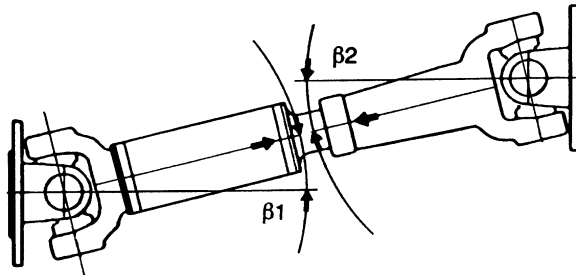

T9006113

Notes

Specifying the Pump

The PTO and the hydraulic pump must be selected to function properly in the application(s) for which the truck is intended. For example, a refrigeration unit must continue to operate while the vehicle is mobile, and the dump body must continue to operate while the vehicle is stationary. The PTO and pump also must have sufficient flow — dependent on oil flow, pressure, and the efficiency of the pump — to perform the designated work. The pump must be specified to achieve the flow of hydraulic oil required to ensure satisfactory operation of the equipment.

Input Data

The equipment driven by the hydraulic system requires a certain oil flow and working pressure. The components driving the hydraulic system must not be overloaded.

Several variables affect specification of the correct PTO/pump combination for the hydraulic system. Typically, this information can be found on the *hydraulic equipment manufacturer's* data sheet. Equipment power requirements can include:

- Oil flow (Q) in LPM (GPM).
- Oil pressure (p) in bar (psi).
- Permitted torque/power output of the PTO.
- Permitted speed of the pump.
- Truck operating speed (spreading).

Calculating pump displacement cc/rev (in³/rev)

$$D = \frac{Q \times 231}{N_e \times Z} \quad \text{or} \quad \frac{D \times N_e \times Z}{231}$$

Calculating PTO/pump torque Nm (ft-lb)

$$T = \frac{D \times p}{74}$$

Calculating PTO/pump power kW (hp)

$$P = \frac{Q \times p}{1680 \times n}$$

Checking maximum PTO/pump speed (rpm)

$$N_p = N_e \times Z \quad \text{or} \quad N_e = \frac{N_p}{Z}$$

Q	=	Flow	LPM (gpm)
Ne	=	Engine speed	(rpm)
Np	=	Pump speed	(rpm)
Z	=	PTO ratio	(0.60, 0.73, 0.91, 1.23, 1.30, 1.54, 1.62)
D	=	Dump displacement	cc/rev (in ³ /rev)
p	=	Working pressure	bar (psi)
P	=	Power	hp (kW)
T	=	Torque	ft-lb (Nm)
μ	=	Efficiency	0.75 - 0.85 Gear Pump 0.90 - 0.95 Piston Pump

Pump Capacity, Displacement

The pump capacity or size (D = cc/rev (in³/rev)) must be able to offer sufficient flow (Q = LPM (GPM)) for the proper operation of the equipment. The selection of the pump size depends on the desired flow, engine speed, and PTO ratio. A small pump can allow a large flow if the PTO ratio or engine speed is high enough.

Use the following to calculate pump size:

D Pump Size cc/rev (in³/rev)

Q Flow LPM (GPM)

Ne Engine Speed (rpm)

Z PTO Ratio

$$D = \frac{Q \times 231}{Ne \times Z} \quad \text{or} \quad Q = \frac{D \times Ne \times Z}{231}$$

RECOMMENDATION

Select the highest possible PTO ratio and the smallest pump size that meet the requirements without exceeding the pump speed, pressure, and power limits.

PTO/Pump Power Requirements

The engine must provide sufficient power to drive the pump.

The power (P) required to drive the pump is in direct proportion to the flow and working pressure, and is in inverse proportion to the pump efficiency (n).

Use the following to calculate the engine power requirement:

- P** Power kW (hp)
- Q** Flow Through the Pump LPM (GPM)
- p** Working Pressure
- n** Pump efficiency

$$P = \frac{Q \times p}{1680 \times n}$$

Engine Operating Speed Recommendation

PTO Power Requirement hp (kW)	Engine rpm (Ne)
< 40 (30)	700 - 800
42-67 (31 - 50)	800 - 900
68-94 (51 - 70)	900 - 1000
> 95 (71)	>1000

Notes

Checking PTO Torque

A certain torque is required from the PTO on the pump shaft to drive the pump. This torque should be less than that which is permitted on the PTO itself.

Use the following to calculate the PTO torque:

- T** Torque — Nm (ft-lb)
- D** Pump Size — cc/rev (in³/rev)
- p** Hydraulic System Pressure — bar (psi)
- T_{perm}** Permitted Torque on PTO (< Engine Torque)

Note: If only the engine power curve is available, check as described in “PTO/Pump Power Requirements”, page 51 .

$$P = \frac{Q \times p}{1680 \times n} < T_{perm}$$

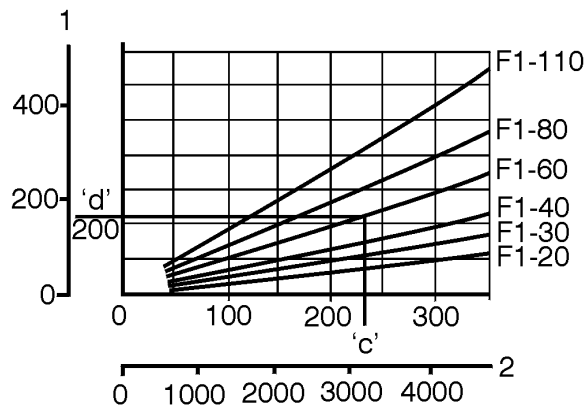

W4002390

Torque Curve, Parker/VOAC Pumps

Notes

Speed Check

Make sure that the permitted speed of the pump (as stated by the pump manufacturer) is not exceeded.

The pump speed (N_p) is governed by the engine speed (N_e) and the PTO ratio (Z).

Use the following to calculate pump speed:

N_p Pump Speed/Minute

N_e Engine Speed (rpm)

Z PTO Ratio (%)

Constant speed during driving is obtainable with a variable pump. The engine speed (N_e) for a clutch-dependent PTO is often set to operate around 1000 rpm (engine). If the PTO is driven with an inappropriately low engine speed, an uneven flow can occur as the engine speed drops during loading.

$$N_p = N_e \times Z \quad \text{or} \quad N_e = \frac{N_p}{Z}$$

Power Requirements vs. Engine Speed

PTO Power Requirement hp (kW)	Engine rpm (N_e)
< 40 (30)	700 - 800
42-67 (31 - 50)	800 - 900
68-94 (51 - 70)	900 - 1000
> 95 (71)	>1000

Notes

Supply and Pressure Lines

The size (diameter and length) of the supply/pressure lines also will affect the function of the hydraulic system (see “Hydraulic Line Requirements”, page 55).

The supply line should be of sufficient diameter and minimum length without restrictions (pipe adapters) between the pump and the oil reservoir connection. A pressure line with insufficient diameter will create unnecessary pressure losses in the form of heat. A flow of 11.5 LPM (30 GPM) with a pressure drop of 9.65 bar (140 psi) will generate approximately 1.7 kW (5800 BTU).

Use a calculation sheet to determine the correct PTO/pump combination (see “Calculating/Selecting a PTO and Matching Pump”, page 54 .

Calculating/Selecting a PTO and Matching Pump

Customer	_____		
Vehicle	_____		
Engine	_____		
Transmission	_____		
Equipment	_____		
1. Equipment flow demand	Q =	_____	lpm (gpm)
2. Working pressure	p =	_____	bar (psi)
3. PTO alternative ratio	Z =	_____, _____, _____	
4. Pump alternatives	D =	_____, _____, _____	
5. Engine working speed	Ne =	_____, _____, _____	rpm

Pump displacement cc/rev (in³/rev)

$$D = \frac{Q \times 231}{Ne \times Z} \quad \text{or} \quad \frac{D \times Ne \times Z}{231}$$

PTO/pump power kW (hp)

$$P = \frac{Q \times p}{1680 \times n}$$

PTO/pump torque Nm (ft-lb)

$$T = \frac{D \times p}{74}$$

Hydraulic Line Requirements

Supply Pipe/Line

The figures in the table show the minimum inside diameter without restrictions (pipe adapters) of a supply pipe from the tank into the pump needed to avoid cavitation (noise). Other parts of the system can be designed differently, depending on installation requirements.

Minimum Inside Diameter

VOAC F1 - Pump	Inside Diameter of Supply Pipe	
F1-61	38/50 mm	1.5/2.0 in.
F1-81/101	50/65 mm	2.0/2.5 in.



CAUTION

A supply line with insufficient diameter will create cavitation damage and low pump efficiency.



WARNING

Hydraulic fluid level should be above the supply port of the pump or pump failure will occur.

Pipe/Line Selection

To prevent cavitation (noise) damage and excessive pressure losses (heat), the inside diameter of the pipe must be the correct size. Do not exceed the maximum flow speeds.

Maximum Allowable Flow Speeds

Line Type	Pressure bar (psi)	Flow Speed m/s (ft/s)
Supply	—	0.45 – 1.07 (1.5 - 3.5)
Pressure	103 – 310 1500 - 4500)	3.05 – 4.88 (10 - 16)



CAUTION

A pressure line with insufficient diameter will create unnecessary pressure losses which will appear as heat. A flow of 113.5 LPM (30 GPM) with a pressure drop of 9.65 bar (140 psi) will generate approximately 1.7 kW (5800 BTU), which can cause abnormal wear and damage to components.

Select the smallest inside line diameter that meets the flow speed recommendations.

Recommended Inside Line Diameter

Fluid Flow	Flow Speed m/s (ft/s) at Indicated Inside Line Diameter				
	19.1 mm (0.75 in.)	25.4 mm (1.00 in.)	31.8 mm (1.25 in.)	38.1 mm (1.50 in.)	50.8 mm (2.00 in.)
LPM (gpm)					
37.9 (10)	2.23 (7.3)	1.25 (4.1)	0.79 (2.6)	0.55 (1.8)	0.3 (1.0)
56.8 (15)	3.32 (10.9)	1.86 (6.1)	1.19 (3.9)	0.82 (2.7)	0.46 (1.5)
75.7 (20)	4.42 (14.5)	2.5 (8.2)	1.58 (5.2)	2.0 (3.6)	0.61 (2.0)
94.6 (25)	N/A	3.1 (10.2)	1.98 (6.5)	1.37 (4.5)	0.79 (2.6)
113.6 (30)	N/A	3.75 (12.3)	2.38 (7.8)	1.68 (5.5)	0.91 (3.0)

Pressure Pipe

Supply Pipe

Oil Reservoir Tank

As a guide, an oil reservoir tank with a capacity 1 or 2 times the pump flow/minute will be sufficient. For shorter periods of operation, a smaller capacity may be used.

Prior to installation, the oil reservoir must be cleaned to remove all manufacturing debris. The inside area should be treated with oil-resistant paint. Prior to filling the tank, the oil should be poured through a filter to eliminate any possibility of dirt entering the tank. An oil filter with a rating of 10 microns (absolute) should be installed in the tank or return line. Oil filters should be changed annually.

RECOMMENDATION

51 mm (2 in.) supply line should be used between pump and reservoir (with no reducer fitting), supply line restrictions should be minimized.

RECOMMENDATION

51 mm (2 in.) ball valve should be used as shut-off device whenever feasible.

Notes

Hydraulic Piston Pumps

Volvo Trucks North America offers both single and twin-flow Parker hydraulic pumps, which can be driven in the following ways:

- Direct-driven pump – can be mounted directly on the PTO, either at the factory or by the body builder company, in accordance with the DIN 5462/ISO 7653 standard. All Parker F1 and F2 pumps can be direct mounted to either the transmission or engine PTO.
- Single driveshaft driven pump – can be driven by a driveshaft connected to the PTO SAE 1310/1410 flange and are typically mounted by the body builder company.

F1 and F2

Pump Frame Size	25	41	61	81	101	42 A	42 B	53 A	53 B
Displacement (cu.in/rev)	1.56	2.50	3.63	4.98	6.28	2.62	2.50	3.29	3.17
Max Continuous Pressure	3,600	3,600	3,600	3,600	3,600	5,000		5,000	
Max Intermittent Pressure	5,000	5,000	5,000	5,000	5,000	5,800		5,800	
Min Speed RPM @ Max Pressure Max	2700	2700	2700	2300	2300	2,550		2,550	
	2200	2100	1900	1750	1550	1800		1800	
Continuous Max Output Horsepower Intermittent	26.8	36.2	45.5	54.9	64.3	117		147	
	34.8	49.6	59.0	72.3	83.1	134		168	
Weight (lbs)	18.7	18.7	18.7	27.5	27.5	41.8		41.8	

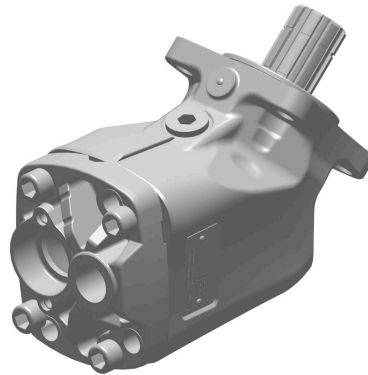

T9200446

The F1 and F2 are piston pumps that are larger in size than the GP1, piston pumps are more efficient than gear pumps and therefore produce less heat during the operation.

Piston pumps are 97% efficient at ~1000 rpm.

F1 pump features:

- Higher self-priming speeds
- Operating pressures to 400 bar
- Higher overall efficiency
- Increased reliability
- Reduced noise level
- Easier to change direction of rotation
- Optimized commutation - low flow pulsations
- Installation above the reservoir level possible
- Smaller installation dimensions

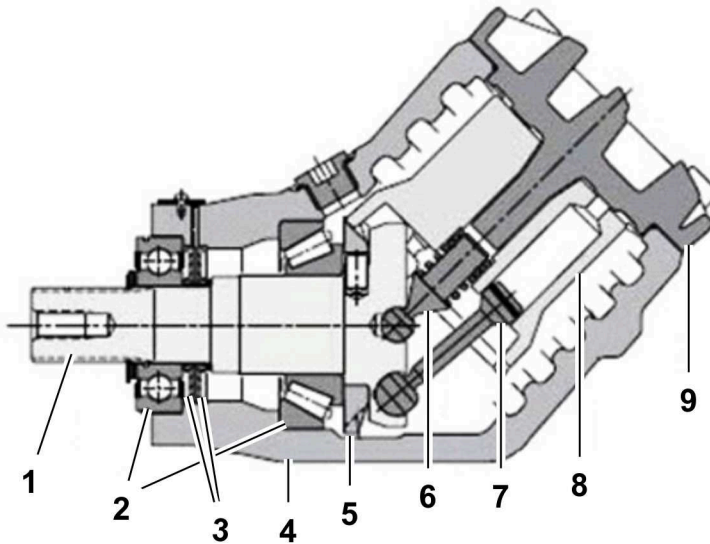

W9124202

1. Input shaft
2. Bearings
3. Shaft seals
4. Housing
5. Timing gear

6. Barrel support
7. Piston with piston ring
8. Cylinder barrel
9. End cap

Pump rotation change RH to LH (applies to F1 series only)

Recommend holding pump in vise: Follow steps (a) through (e) below.

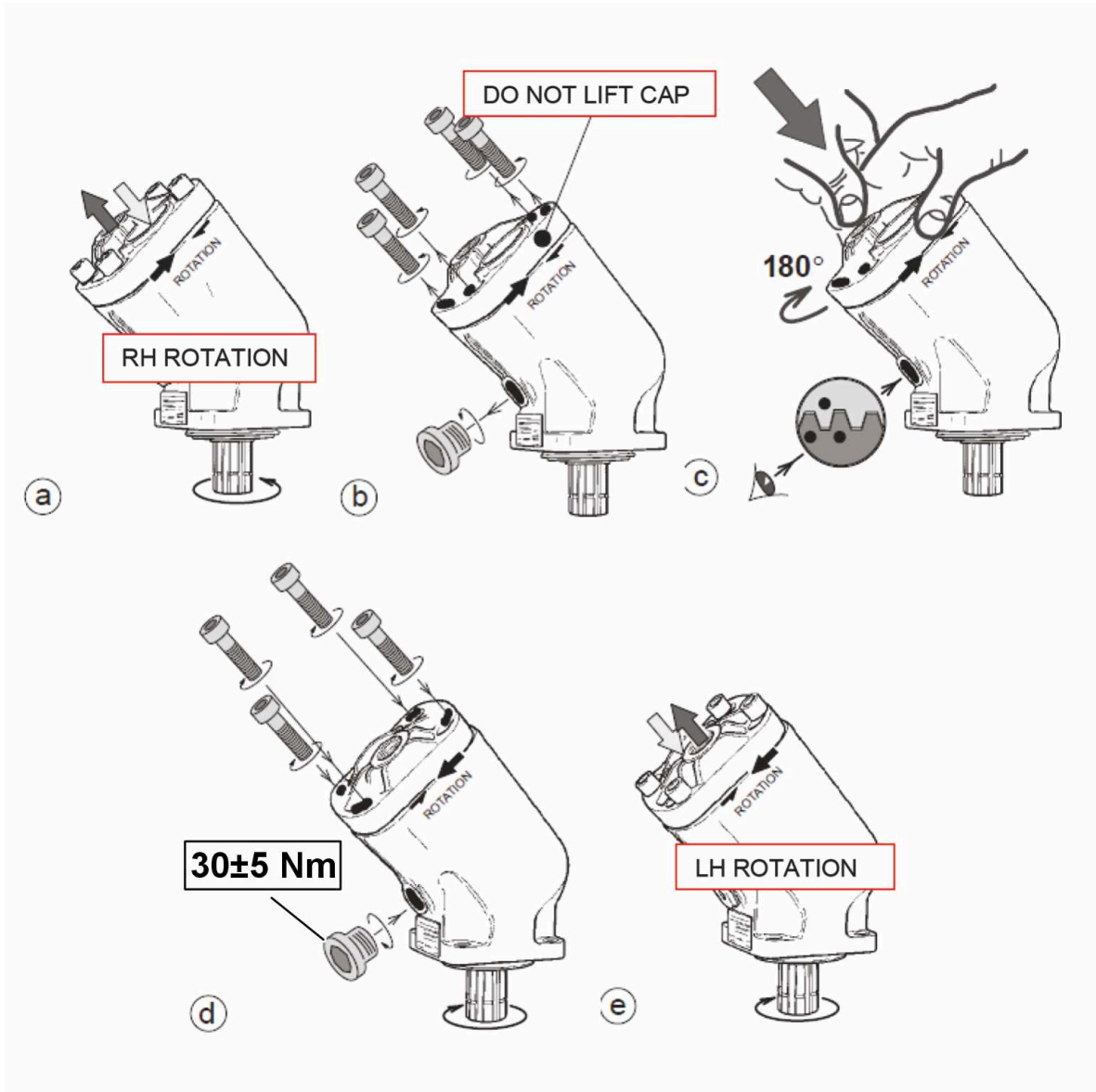

T9200585

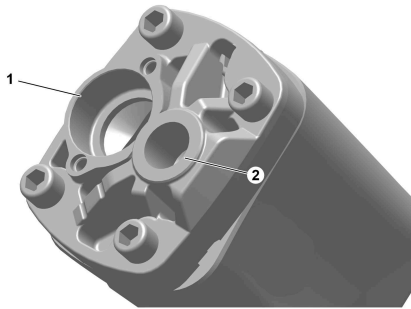

T9200449

- 1. Suction port
- 2. Pressure port

Left hand rotation

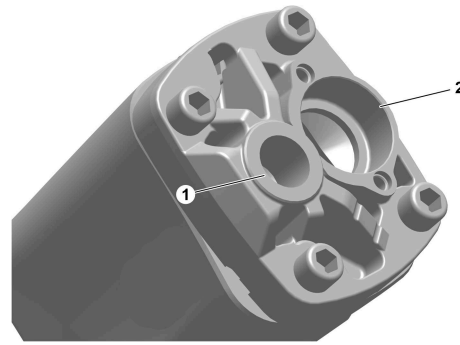

T9200450

- 1. Pressure port
- 2. Suction port

Right hand rotation

F2 pump features:

Series F2 is a further development of the twin-flow version of series F1, the very first bent-axis truck pump on the market to feature two entirely independent flows. With a suitable build-up of the hydraulic system, the main advantage with a twin-flow pump is that three different flows can be provided at the same engine speed. The twin-flow pump makes it possible to further optimize the hydraulic system and offers:

- Less energy consumption
- Reduced risk of system overheating
- Lower weight when compared to installation of two pumps
- Easier installation
- Standardized system solutions

The twin-flow pump makes it possible to operate two work functions that are independent of each other while allowing higher speed and an increased operating precision. Another requirement can be a large and a small flow, or two equal flows. All of these alternatives are possible with the twin-flow pump.

The pump can be utilized to provide one flow at high system pressure, and, as soon as the pressure has decreased sufficiently, add the flow from the other circuit. This eliminates the risk of exceeding the PTO power rating and, at the same time, provides an optimal driving function.

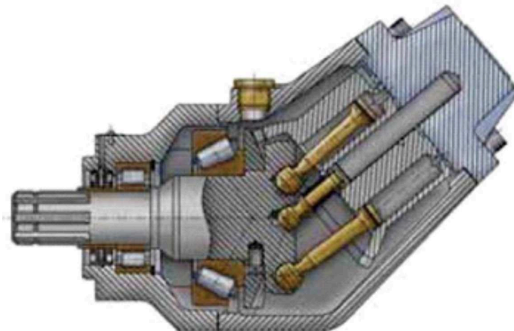

W9114243

Parker provides charts to determine the most suitable pump for a PTO operation; the charts are in metric so a conversion to conventional US units is required.

1 bar = 14.503 psi

1 Liter = .26417 gallons

1 kW = 1.3404 hp

Pump Flow (gpm) at Pump Speed (rpm)							
Pump	1000 rpm	1200 rpm	1400 rpm	1600 rpm	1800 rpm	2000 rpm	2200 rpm
F1-25	6.8	8.1	9.4	10.8	12.2	13.5	14.9
F1-41	10.8	12.9	15.1	17.2	19.4	21.6	23.7
F1-61	15.7	18.9	22.0	25.1	28.3	31.4	34.6
F1-81	21.6	25.9	30.2	34.5	38.8	43.1	-
F1-101	27.0	32.4	37.8	43.2	48.5	-	-
F2-42/42	11.3/10.8	13.6/13.0	15.9/15.2	18.1/17.3	20.4/19.5	-	-
F2-53/53	14.3/13.7	17.1/16.5	20.0/19.2	22.9/22.0	25.6/24.7	-	-

* Refer to the specific Product Information bulletins in TM2 for pump housing dimensions and performance.

Note: A new gasket is necessary, when installing a new pump. The gasket is available as part number 20551226.

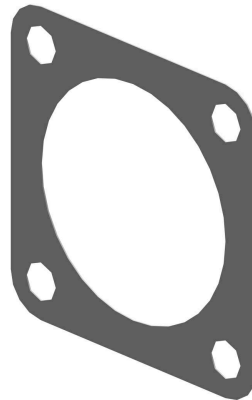

T9200451

Notes

Pump Bearing Life

Bearing life is dependent on how the pump is installed on the PTO as shown in the illustrations below.

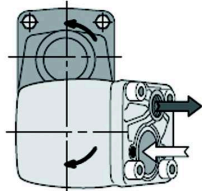

Left hand (L.H.) rotating pump

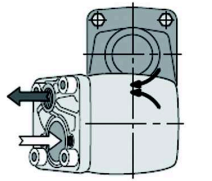

Right hand (R.H.) rotating pump

Fig. 1.

Bearing life is dependent on how the pump is installed on the PTO as shown in the illustrations below.

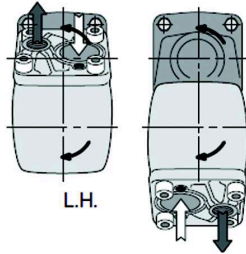

L.H.

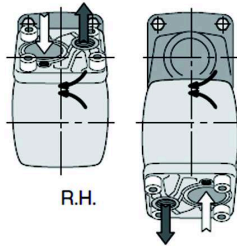

R.H.

Fig. 2.

Parker Hannifin will assist in determining bearing life in a particular application.

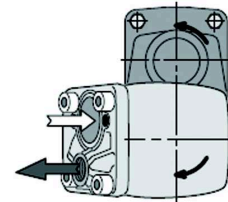

L.H.

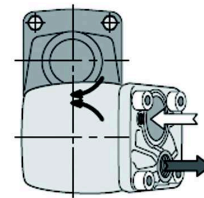

R.H.

Fig. 3.

BPV-F1 Bypass Valve

An F1 pump supplied with a bypass valve can be utilized in applications where the pump is operating constantly i.e. when the pump is driven from the crankshaft through a driveshaft or it can be installed on a PTO. In most cases, the bypass valve allows the pump to be driven at max engine rpm during transportation at no load. This prevents pump cavitation and high heat generation which may otherwise be encountered at large flows. The BPV valve connects the outlet and inlet ports of the pump, and only a small oil flow goes through the system to the tank. The valve is installed directly on top of the pump port surface with 'banjo' fittings. As the BPV valve is symmetrical it can be 'turned 180°' to suit either left hand or right hand pump rotation, or to prevent interference with chassis components. The valve can only be engaged or disengaged (through a 24V DC solenoid) at no-load system pressure.

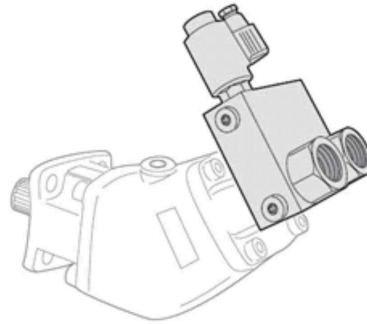

W9114244

Bypass Valve			
Model	Pump Application	Parker Part No.	Volvo Part No.
BPV-F1-25	F1-41, F1-51, F1-61, F1-25	3787047	21230082
BPV-F1-81	F1-81, F1-101	3787048	21230083
BPV-F2	F2-42, F2-53	3781774	20374479

BPV-F1-25 and -81 Bypass Valve

The bypass valve is mainly utilized in applications where the F1 pump is driven from the crank-shaft through a driveshaft. The BPV bypass valve should be engaged during transportation when the pump is operating constantly and the engine is running at max rpm; the hydraulic system is not sized for the large flow that would otherwise go through it. The BPV valve substantially reduces the energy loss during transportation. The valve installs directly on top of the pump end cap with a pressure port 'banjo' fitting and an inlet port spacer bushing with two cap screws; refer to the illustration below. As the BPV valve is symmetrical, it can be 'turned 180°' to prevent interference with chassis components; it can be utilized for either left hand or right hand pumps. The valve function must only be activated or released (by means of a 24V VDC solenoid) at no-load (below 290 psi) system pressure.

Important Information

In order to prevent heat build-up in the pump during transportation, it is important that at least 1.3 gal/min comes out of the filter at 'q' (refer to the schematic). This applies to an "open center" system when the valve is in the bypass mode (non-activated solenoid).

Note: a) If the flow at 'q' is less than 1.3gal/min (caused e.g. by high pressure drop in the main system) when the valve is in the bypass mode.

b) If the hydraulic system is of the 'closed center' type, then an external drain line must be installed from the bypass valve drain port directly to tank as shown in the schematic; a drain kit is available.

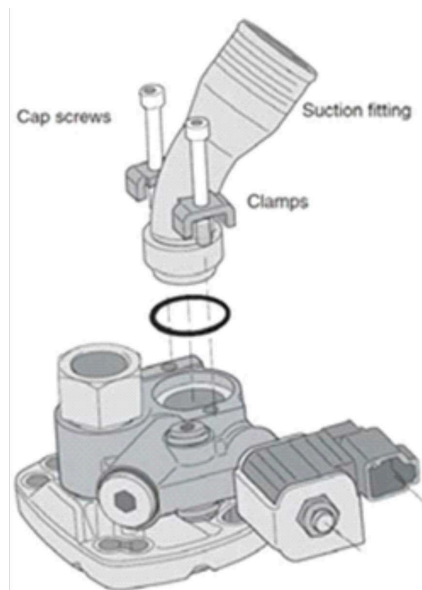

W9114245

Hydraulic Wet Kits

Use of the Parker F1, F2, and GP1 pumps requires components that are not traditionally installed into NA truck hydraulic systems.

1) To modulate the flow of oil so that the operation of the hydraulic system can be regulated traditional systems use a control valve that is incorporated into the pump assembly. The Parker F1, F2, and GP1 require the addition of an oil flow regulator to be installed in the circuit remotely from the pump to control the flow of the oil from the pump to the system actuator.

2) Parker F1 and F2 pumps run very tight tolerances to achieve the 97% pump efficiency so the system requires that a filter element be installed into the return line to filter out debris as the oil returns to the tank. A pressure gauge is recommended to be installed in the filter housing to indicate when the filter element has trapped sufficient debris that it restricts the flow of oil back to the tank and requires the replacement of the filter.

Installation and Start-up for F1 and F2 Hydraulic Pumps

Fluids — Need to operate with a high quality, mineral based hydraulic oil. Type HLP hydraulic oil is suitable, as well as biologically degradable fluids like natural and synthetic esters and polyalphaolefins.

- SS 15 54 34
- SMR Hydraulic Oil Standard 1996-2

*Contact Parker Hannifin for further information.

Start-up — Make sure the entire hydraulic system is clean and the pump is filled (to at least 50%) with a recommended hydraulic fluid, as the internal leakage does not provide sufficient lubrication at start-up.

Drain Line — Fixed displacement pumps don't need an external drain line as they are internally drained. However, when the pump is mounted on an engine PTO, it is recommended to mount a drain line from the bypass valve directly to the oil tank if in doubt.

Notes

High Pressure Hose

These hoses must be designed to withstand the high pressure in the hydraulic system. When installing a high pressure hose:

- Make sure the hoses are not twisted when connected.
- Make sure the hoses are long enough.
- Strive to get as few bends as possible on a hose.
- Avoid kinks by using correct unions.

Parker Hannifin Pressure Fittings

A special pressure fitting is required to convert the threads in the pump from BSPP to SAE J37. These fittings are available from Volvo Trucks under the following part numbers.

Volvo Part Number	Pump Size	BSPP Thread	Tube Size mm (in)
PHV-12F40MXS	F1-41, F1-51, F1-61 F2-52 / 52, F2-42 / 42 GP1-23, GP1-41	3/4 x 14	19 (3/4)
PHV-16F40MXS	F1-81, F1-101	1 x 11	25 (1)
PHV-1620F40MXS	GP1-60, GP1-80, GP1-100	1 1/4 x 11	25 (1)
PHV-20F40MXS	GP1-60, GP1-80, GP1-100	1 1/4 x 11	30, 32 (1 1/4)
PHV-24-20F40MXS	GP1-60, GP1-80, GP1-100	1 1/4 x 11	38 (1 1/2)

Hydraulic Pumps Offered By Volvo

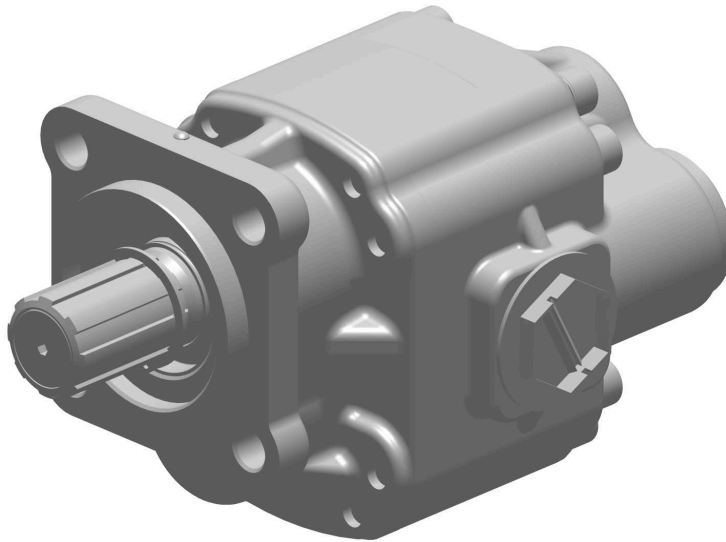

T9200448

Parker Gear Pumps		
Model	Parker Part No.	Volvo Part No.
GP1-23	3789383	22045713
GP1-41	3789384	22045714
GP1-60	3789385	22045715
GP1-80	3789386	22045716
GP1-100	3784184	22725227

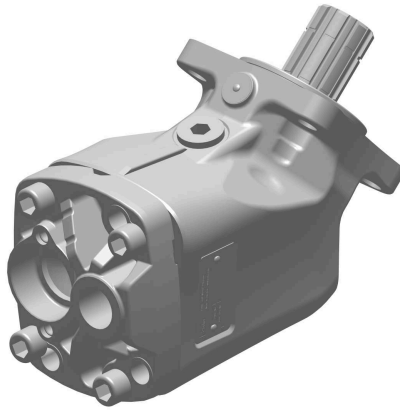

T9200446

Parker Bent Axial Piston Fixed Pumps		
Model	Parker Part No.	Volvo Part No.
F1-25	3781524	20455918
F1-41	3781540	20392941
F1-51	3781550	20392942
F1-61	3781560	20392943
F1-81	3781580	20392944
F1-101	3781600	20392945
F2-42 / 42	3785783	20909025
F2-53 / 53	3783573	20458341

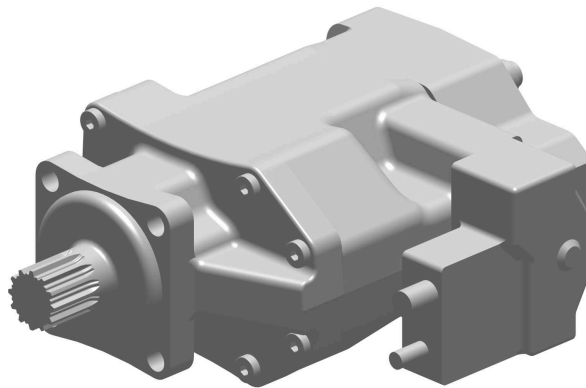

T9200447

Parker Dump Pump		
Model	Parker Part No.	Volvo Part No.
G102	3089310913	22745915

Note: Pump specifications can be found in the Pump Speed Calculator or at www.parker.com

Flow Pump, Exploded View

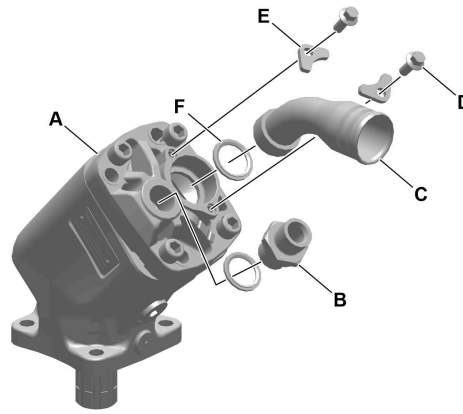

T9200453

Flow Pump, Exploded View	
A	Pump Assembly
B	Pressure Fitting
C	Supply Tube Kit
D	Screw, included in Supply Tube Kit
E	Clamp, included in Supply Tube Kit
F	O-ring, included in Supply Tube Kit

PTO Fittings

45 Fitting				
Part Numbers	A mm (in)	B mm (in)	C mm (in)	D diameter (in)
21167887	95 ± 2 (3.74 ± 0.078)	62.5 ± 2 (2.46 ± 0.078)	19.6 ± 0.05 (0.77 ± 0.0019)	Ø 50.5 ± 0.5 (1.98 ± 0.019)

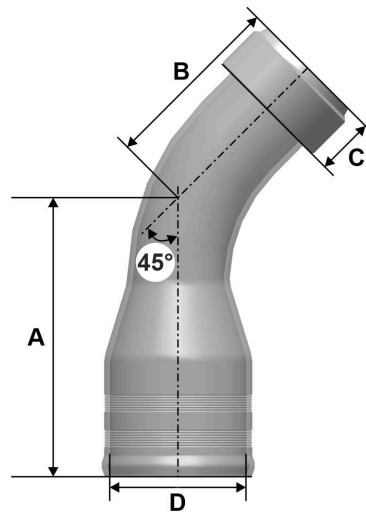

T9200470

60 Fitting				
Part Numbers	A mm (in)	B mm (in)	C mm (in)	D diameter (in)
21056910	118 ± 2 (4.64 ± 0.07)	73.5 ± 2 (2.89 ± 0.07)	19.6 ± 0.05 (0.77 ± 0.0019)	∅ 63 ± 0.5 (2.48 ± 0.019)

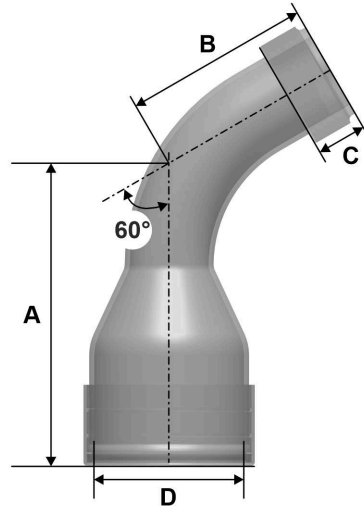

T9200471

90 Fitting				
Part Numbers	A diameter (in)	B mm (in)	C diameter (in)	D mm (in)
22045741	19.05 (0.75) / 31.75 (1.25)	44 ± 1 (1.73 ± 0.03)	38.1 (1.5) / 50.8 (2)	82 ± 1 (3.22 ± 0.03)

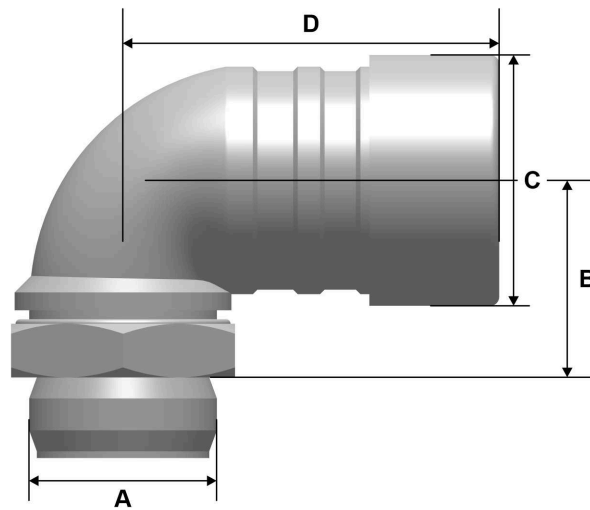

T9200472

Note: All pumps have a right hand direction of rotation as seen from the PTO (looking to the front of the vehicle).

Note: All supply fittings come in kit form. Includes clamps, bolts, and O-ring.

PTO Speed Functions

For the purposes of this manual, PTO (Power Take-Off) is a function to maintain engine speed regardless of engine load. Think of it as cruise control for the engine - only instead of maintaining a steady vehicle speed, it is maintaining engine speed. It is most often used to provide increased steady engine speed when operating auxiliary equipment such as hydraulic pumps or compressors. The term "PTO" has come to mean both the function of maintaining constant engine speed during use of auxiliary equipment, as well as a term for the auxiliary equipment itself.

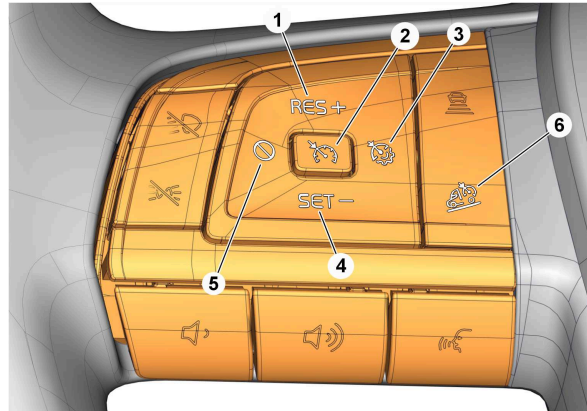

T3202462

- 1 Increase set speed/Resume Cruise
- 2 Cruise Control Enable
- 3 Cruise Over/Under Speed Setting
- 4 Decrease Set Speed/Resume Cruise
- 5 Cancel Cruise
- 6 Downhill Cruise Set

There are two types of mode to control PTO engine speed:

Using the engine speed control at low speeds

The engine speed control can be used at very low speeds, below 2 mph, such as when laying asphalt.

- 1 Press the Cruise Control Enable button (2).
- 2 Drive and maintain the engine speed at 1000 rpm.
- 3 Press the SET button (4).
- 4 Release the accelerator pedal.

The engine speed can be reduced to 600 rpm and the truck rolls steadily.

The lowest speed depends on the truck's powertrain. A truck with crawler gear can maintain a speed of 0.5-2 mph at 600 rpm.

Constant engine speed

The engine speed can be temporarily changed to suit the work being carried out.

Note: The engine speed control is only available at low speeds.

- 1 Press the Cruise Control Enable button (2). A menu opens in the instrument display.
- 2 Select Engine control in the menu.
- 3 Press the SET/- button (4) or Cruise Control Enable button (2) or wait a moment for engine control to be selected.
- 4 If you want to raise or lower the engine speed, press the RES/+ button (1) or SET/- button (4).
- 5 To increase the engine speed to a pre-programmed value (normally 1000 rpm), press the RES/+ button (1).

To resume to the original engine speed, press the Cancel Cruise button (5).

To deactivate constant engine speed, press and hold the Cancel Cruise button (5).

Note: During a regeneration of the diesel particulate filter, the idling speed will be slightly increased without the possibility of changing it.

A cab harness overlay is necessary, when installing a BBM in a cab that was not originally equipped with one.

To verify whether the vehicle has a VMCU or a BBM, remove the Fuse and Relay Center (FRC) and look at the module located below it.

Notes

Power Take-off Controls

All Volvo trucks ordered from the factory with I-Shift or engine mounted PTOs will come pre-wired to the “primary” PTO controller in the Vehicle Master Control Unit (VMCU). Also included are a dash mounted engagement switch, wiring to the VMCU and wiring to the PTO solenoids. The engine speed is controlled through the cruise control switches and can be regulated up and down based off parameters set in the VMCU. This configuration provides a limited control system for the PTO.

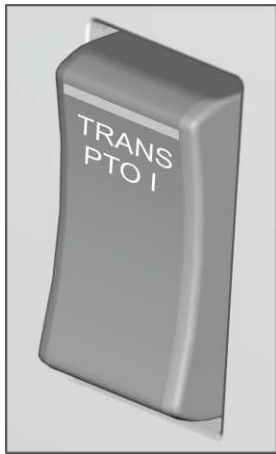

T3199508

PTO 1 Dash Switch



T3199507

PTO 2 Dash Switch

Where vehicles need to drive multiple PTOs or have advanced controls for a single PTO, a body builder module should also be specified. If a vehicle is ordered without the body builder module and it is later determined it is needed, an Aftermarket kit is available which converts a vehicle to the “Advanced” level controls.

Note: *The cost of installing the retrofit kit is significant, compared to having it factory installed.*

“Basic” PTO Controls

Capabilities:

- Cruise control (Steering wheel switches) PTO Engine Speed controls

Hardware / Pre-wiring included:

Vehicle Master Control Unit (VMCU), with support for 2 PTO mode only

Notes

PTO Programming

There are multiple customer-changeable parameter settings for the VMCU and BBM ECU.

For each ECU, there are two types:

"Vehicle" parameters; these are field-changeable using the Premium Tech Tool (PTT) with a network connection. The network connection provides a centralized record of the changes maintained by Volvo Trucks North America.

"Customer" parameters; these are field-changeable using the Premium Tech Tool (PTT) without a network connection. For each parameter, there is given Parameter Name - note that the name given here is intended to be the name which is presented in the Premium Tech Tool (PTT), but it may be different from the internal parameter name. In case of any questions, always use the parameter code to verify that it is the required parameter.

There are no "Vehicle" parameters for the BBM. All field-accessible parameters are customer-parameters and can be adjusted by the Premium Tech Tool (PTT) without the need for a network connection.

Certain parameters will need to be set by the dealership prior to arriving to the body builder or customer.

Parameters PTO1

Parameter code	Description	Min	Default value	Max
P1D4E	PTO1 Activation Condition, Engine Speed	500	1000	3050
P1CVG	PTO1 Activation Condition, Vehicle Speed	0	30	255
P1F79	PTO1 minimum engine speed limit	300	600	2550
P1F75	PTO1 maximum engine speed limit	600	1700	2550
P1CYD	PTO1 maximum road speed limit	5	30	255
P1I4L	PTO1 minimum system air pressure before activation	0	8	20,4
P1CU6	PTO1, Engagement Consent Signal from TECU, Enable	-	False	-

Parameters PTO2

Note: The default maximum engine speed setting can vary depending on pump installed.

Parameter code	Description	Min	Default value	Max
P1D4F	PTO2 Activation Condition, Maximum Engine Speed	500	1000	3050
P1CVH	PTO2 Activation Condition, Maximum Vehicle Speed	0	30	255
P1F8A	PTO2 minimum engine speed limit	300	600	2550
P1F76	PTO2 maximum engine speed limit	600	1700	2550
P1DGO	PTO2 maximum road speed limit (Unit: km/h)	5	30	255
P1I4M	PTO2 minimum system air pressure before activation 296 = Disabled (Unit: PSI)	0	116	296
P1CU7	PTO2 consent from gearbox enabled	-	False	-

Support Options:

- Online Body Builder support: eMedia Center Volvo Trucks North America- <http://www.volvotrucksemedia.com/>
- Volvo Dealers are to contact Tech Support by utilizing the eService application providing as much detail as possible.
- Volvo Dealers and Body Builders can contact the Body Builder Support line directly at 877-770-7575, Option 2, should additional support be needed. Be ready to provide your model and serial number.

Notes

Calculation Example – Choose and Calculate a PTO/Pump Match

Operating Conditions

Joe Sand, a hypothetical customer, is specifying a Volvo VHD tractor with a Volvo D13 435 hp engine and an I-Shift ATO2612–G transmission. Sand's VNL will pull a 38 foot end dump trailer, which has the following requirements:

- Trailer requires a hydraulic flow rate of 25 gal/min = **Q**
- Working pressure of the system is 2500 psi = **p**
- For quiet and fuel efficient operation, the customer and the body builder consider a suitable engine rpm to be 800 rpm = **N_{eng}**
- End dump trailer is always used when the vehicle is stationary, so a clutch dependent PTO will work
- A direct mount hydraulic pump is recommended by the body builder
- The engine is a D13 and the transmission is a Volvo I-Shift ATO2612–G

A. Calculate the power requirement and specify a suitable PTO with ample capacity:

$$\text{Power (P)} = \frac{25(Q) \times 2500(p)}{1680} = 37.2 \text{ hp}$$

B. Next, check sufficient flow (**Q**) with a F1-61 hydraulic pump preferred by the customer (**D** = 3.63 cu.in./rev) with engine operating rpm (**N_{eng}**) and ratio (**Z**) for selected PTO, T4XDMX, on the high speed split:

$$\text{Pump flow (Q)} = \frac{3.63(D) \times 800(N_{\text{eng}}) \times 1.72(Z)}{231} = 21.6 \text{ gpm}$$

The received flow (Q) is not sufficient for the requirement of 25 gpm. Three options can be used to correct the flow:

- 1 Increase the engine operating rpm (**N_{eng}**).
- 2 Change to a faster PTO ratio (**Z**).
- 3 Use a larger displacement pump (**D**).

Option 3 was accepted by the customer and the pump was changed to one with a larger displacement (F1-81), on the high speed PTO split, which allows an even lower engine rpm for additional fuel savings:

$$\text{Pump flow (Q)} = 231 = 25.9 \text{ gpm}$$

C. Now check the PTO torque (**T**):

$$\text{Torque (T)} = \frac{4.98(D) \times 2500(p)}{74} = 168.2 \text{ lb-ft}$$

D. Last, check that the maximum pump speed is not exceeded:

$$\text{Pump speed (Np)} = 700 (N_{\text{eng}}) \times 1.72 (Z) = 1204 \text{ rpm}$$

This is acceptable as compared to the maximum pump speed on the manufacturer's pump specifications.

Power Take-off Worksheet

Customer _____

Vehicle _____

Engine _____

Transmission _____

Equipment _____

Constant Demands

1. Equipment flow demand $Q =$ _____ GPM

2. Working pressure $p =$ _____ psi

Selectable Variables

3. PTO alternative ratio $Z =$ _____

4. Pump alternatives $D =$ _____ cu.in/rev.

5. Engine working speed $N_{eng} =$ _____ rpm

Notes

Engine Speed Control

ESC from BBM

ESC (Engine Speed Control) can also be activated using hardware inputs located on the BBM or by sending a request over the body builder CAN-bus (BB-CAN).

Requirement

When activating the digital inputs for engine speed modes on the BBM, the corresponding Engine Speed ModeX set-up will become active if the selected conditions for this engine speed mode are fulfilled. If more than one Engine Speed Mode input is active at the same time, engine speed mode 1 will have the lowest priority and engine speed mode 4 the highest.

Activation

When any of the Engine Speed ModeX inputs are activated, the engine speed will raise to the value that is selected in the applicable parameter: "Engine Speed ModeX, Engine resume speed". Engine Speed Modes can be "edge triggered" or "level triggered". When level trig is selected, the engine speed control will reactivate automatically when the exit conditions are not any longer fulfilled and entry conditions are fulfilled.

Edge trigger description
When Edge trigger is set to "Yes": If the function shall be reactivated, due to one or more of the criteria not being fulfilled, the dash switch must be set from Off to On.
When Edge trigger is set to "No": The function is activated when all criteria are fulfilled. The dash switch does not need to be set from Off to On.

Deactivation

Removing the input request to BBM will deactivate corresponding engine speed mode. Depending on parameter configuration, also brake pedal, parking brake and gear engagement can be used for deactivation.

Deactivation delay

It is possible to delay the deactivation of "Engine Speed mode 1" when any of the digital inputs are removed. The delay can be set from 1 to 25 seconds (via parameters). A setting of 0 (zero) means no deactivation delay.

ESC (stepless) +/-

ESC shall be active before adjustments with res + and set – can be carried out. Either the cruise control steering wheel buttons or digital inputs to the BBM can be used.

A short input to the “plus” or “minus” inputs on the BBM will cause changes in steps. Longer inputs will cause ramping behaviour. Parameters are available to control the step and ramp values.

Deactivation is performed by removing the digital input request for active engine speed mode, but, depending on the parameter settings, can also be performed using the brake pedal, parking brake and neutral gear.

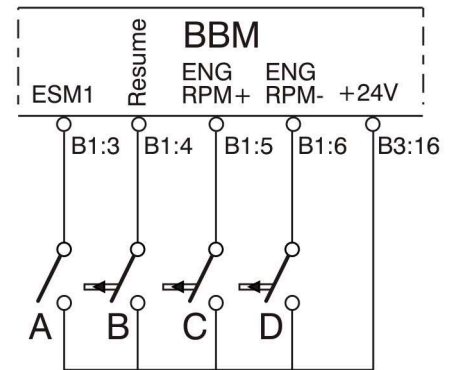

T9078761

Installation example

A — Switch to activate engine speed mode

B — Resume switch

C — Res + (engine speed increase)

D — Set - (engine speed decrease)

Power to the switches should be taken from the BBM (B3:16) which is short circuit protected.

Resume

The resume function is related to the engine speed modes. This means that when any of the engine speeds have been adjusted from the default value for active mode, to another value, a positive pulse on the resume digital input B1:4 will bring the engine speed back to the default value of the active engine speed mode.

This function can be modified by setting parameter P1BTO to 1. This will cause the resume function to toggle between the default value and the value selected using the buttons “set+ / set-”. Every second pulse on B1:4 will bring the engine speed back to the default value for active engine speed mode, and every second pulse back to the modified value. The modified value is removed when the engine is stopped.

Adjusting engine speed in steps or by ramping

Related to each active PTO there are independent parameters for engine speed control, which controls the size of the steps or according to ramps depending on parameter settings.

The ramps will be followed when the related PTO is active, and an engine speed mode is requested or left. Those ramps will also be used in-between different engine speed modes. It is possible to vary the ramp between 10–1000 rpm per second. Value 0 will mean that the ramping will be according to predefined ramps. If the engine, due to heavy load, cannot follow the requested ramp, the ramp will be requested until the target value of requested engine speed mode is reached. The accelerator pedal and second driver interface will override these ramps. Also when no PTO is engaged the engine speed mode ramps can be controlled by separate parameters.

When more than one step or ramp is valid, the smallest step or flattest ramp will be valid.

Low idle regulation

Low idle regulation will always have highest priority. This means that the engine will always try to stay above the low idle engine speed, irrespective of the selected “engine speed mode resume speed”. Note however that heavy loads can temporarily bring the engine speed below low idle, or even cause the engine to stall.

When using engine speed control, it is recommended that the engine speed, which is requested is slightly higher than low idle speed when power is taken out from any PTO.

Minimum engine speed for PTO

A minimum engine speed can be selected for each PTOs. This engine speed will be automatically activated when the related PTO is active and the gearbox is in neutral gear.

The engine speed will automatically return to normal low idle when the corresponding PTO is deactivated or gearbox put in gear unless any other engine speed request is active.

ESC via BB CAN

Engine speed can be requested over the BB CAN network. This is done via a TSC1 request, further described in VBI chapter BB CAN.

When engine speed request over BB CAN, via TSC1 requests, is enabled with parameter P1BTE, the digital inputs to request that engine speed will be disabled.

Notes

Engine speed related parameters

General parameters

Parameter code	Description	Min	Default value	Max	Unit
P1F7M	Specifies maximum engine speed available via cruise control buttons or digital inputs to the BBM Unit: r/rpm	600	2500	2550	r/min
P1F7N	Specifies the minimum engine speed, which can be achieved when engine speed control (set via the cruise control buttons) is active. This will also be the minimum speed when using the cruise control - (minus) button or the digital decrease engine speed input to the BBM. Unit: r/rpm	300	600	2550	r/min
P1B0V	Maximum vehicle speed for engine speed control set using the cruise control buttons. Engine speed control will exit when the selected vehicle speed is reached. When changing to a value above 15 km/h, also parameter P1BYF and P1BXW for cruise control must be changed to have a higher value than P1B0V. Unit: km/h	0	12	30	km/h
P1IZF	Engine speed step up size when increasing engine speed with cruise control + (plus) button or digital increase engine speed input to the BBM. Step size is 10 r/min Unit: r/rpm/step	0	50	250	r/min/step
P1IZG	Engine speed step down size when decreasing engine speed with cruise control - (minus) button or digital decrease engine speed input to the BBM. Step size is 10 r/min Unit: r/rpm/step	0	50	250	r/min/step
P1BUQ	Time threshold before the engine speed (set by pressing cruise control set+/set- buttons) changes by ramping instead of stepping. Unit: s	0	0.5	2,5	s
P1BTQ	Engine speed trim factor for engine speed ramp up when using cruise control buttons or digital increase engine speed input to BBM. Unit: r/rpm/s	0	250	1000	r/min/s
P1BTP	Engine speed trim factor for engine speed ramp down when using cruise control buttons or digital decrease engine speed input to BBM. Unit: r/rpm/s	0	250	1000	r/min/s
P1BTO	Toggling function for engine speed resume switch. True/False		False		False/True
P1M2B	Time the Work Remote can be out of range before the engine speed automatically returns to low idle engine speed. Value 127.5 will give no time-out and the engine speed will not automatically return to low idle when the Work Remote is out of range. Unit: s	0	5	60	s.

Note: The size of steps and ramps, set using the parameters above, will also be valid for engine speed control from the BBM. Steps and ramps can also be made dependent of an active PTO.

Engine Speed Control characteristics related to active PTO

Engine speed control makes it possible to select the size of steps and ramps depending on which PTO is active. The steps or ramps will be used when engine speed is increased or decreased to reach different engine speed modes. The accelerator pedal or second driver interface will override the ramps.

The primary accelerator pedal and steering wheel buttons for engine speed control can be automatically disabled when a selected PTO is active.

The time between steps and size of the steps is set with the common parameter P1BUQ.

When more than one step or ramp is valid, the smallest step or flattest ramp will be valid. This means that the values, related to active PTOs (described below) cannot be set higher than the corresponding values set for steering wheel buttons, parameters P1BTP and P1BTQ.

Minimum step size is 10 r/min .

Parameter code	Description	Min	Default value	Max
P1IZB	Engine speed step up size, with active PTO1 (Unit: rpm/step)	0	50	250
P1IZH	Engine speed step down size, with active PTO1 (Unit: rpm/step)	0	50	250
P1BTS	Engine speed-increasing ramp, with active PTO1 (Unit: r/min/s)	0	250	1000
P1BTR	Engine speed-decreasing ramp, with active PTO1 (Unit: r/min/s)	0	250	1000
P1IZC	Engine speed step up size, with active PTO2 (Unit: rpm/step)	0	50	250
P1IZI	Engine speed step down size, with active PTO2 (Unit: rpm/step)	0	50	250
P1BTU	Engine speed-increasing ramp, with active PTO2 (Unit: r/min/s)	0	250	1000
P1BTT	Engine speed-decreasing ramp, with active PTO2 (Unit: r/min/s)	0	250	1000

Regeneration in PTO Mode

When a vehicle is being operated in the PTO mode and a diesel particulate filter (DPF) regeneration is commanded (either automatically or manually), the engine must be run at a speed above the minimum speeds listed in the tables below (according to the altitude and ambient temperature in which the vehicle is being operated) so that sufficient heat can be generated in the catalyst for regeneration to occur.

This is important to note, because the rated speed of the PTO must not be exceeded. For example; if the maximum rated speed of the PTO is 900 rpm, the regeneration will not occur while the PTO is engaged. When specifying a PTO for a chassis equipped with a DPF, a PTO having a maximum rated speed above the minimum engine speed listed in the tables below must be specified.

OBD13, OBD15, D13J

	Ambient Temperatures in Degrees C(F)			
	-30° C (-22° F)	-20° C (-4° F)	-10° C (14° F)	-1° C (30° F) and above
Altitude in Meters (ft)	Minimum Engine Speed, RPM			
Up to 500 (1650)	1100	1100	1100	1100
1500 (4900)	1175	1175	1175	1175
2500 (8200)	1251	1251	1251	1251
4270 (14,000)	1325	1325	1325	1325

Active Regeneration

When Regen is required, a message will appear in the instrument display. Active regeneration can only be initiated through the instrument display menu.

If Active regenerations with the PTO engaged are required, the vehicle must be configured as follows:

- Active regeneration must be initiated by using the stalk switch.
- The electronic hand throttle (engine speed control) must be active and set to an engine speed greater than the minimum speeds listed in the preceding charts, taking into account the altitude and ambient temperatures in which the vehicle is being operated.

If the vehicle is not configured as listed above, manual stationary regeneration with the PTO engaged will not occur. When regeneration does not take place, the DPF will become soot-loaded, resulting in engine derate and eventual engine shutdown.

Chassis Equipped with Clean Idle Engine

Effective January 2008, the California Air Resources Board (CARB) requires that vehicles operated in California be equipped with engines having tamper-resistant software which limits the time at which the engine can idle at speeds above low idle (550–700 rpm). With the vehicle stationary and without a PTO engaged, idle time at speeds above low idle are limited to approximately 15 minutes. After 15 minutes, the Engine Management System (EMS) will command the engine to revert back to low idle.

When installing a PTO on a vehicle equipped with a Clean Idle engine, it is very important that the PTO be activated by a switch that provides both engagement and speed inputs to the VMCU so that the EMS knows when, and at what speed the PTO is operating. If the PTO is activated through a pneumatic actuator with no electrical input to the vehicle control system, the Clean Idle function will command the engine back to low idle after approximately 15 minutes. This may result in possible damage to the PTO, equipment or to the product being unloaded.

Aftertreatment System Conditioning (ASC)

Effective mid-March 2008, an Aftertreatment System Conditioning (ASC) function was implemented into the engine management system software. This function increases engine speed periodically in order to increase the temperature inside the diesel particulate filter so that unburned diesel fuel can be oxidized. On these chassis, it is important that PTO be activated by a switch which provides PTO engagement and speed input to the VMCU so that the EMS knows the status of the PTO. If the engine speed control and PTO engage inputs are not enabled and the PTO is engaged, the ASC function will increase engine speed when commanded, resulting in damage to the PTO, equipment or to the product being unloaded. The ASC function will not increase engine speed if the heat mode target speed is greater than the speed selected with the engine speed control.

Summary of PTO Engagement Information

- For vehicles equipped with diesel particulate filter, the PTO MUST be activated by a switch that provides both engagement and speed information to the VMCU when the PTO is engaged, and the vehicle operator must use engine speed control to set engine speed when the PTO is in operation.
- For vehicles equipped with diesel particulate filter, and prolonged periods of engine idle time are required, the engine speed control SHOULD NOT be used to increase engine speed. The engine must be allowed to idle as normal. If prolonged engine idling is necessary, it is recommended that the EMS ECU be programmed with CARB compliant files.
- For vehicles with a diesel particulate filter and a Clean Idle engine, the PTO MUST be activated by a switch that provides engagement and speed information to the VMCU when the PTO is engaged, and the vehicle operator MUST use engine speed control to set engine speed when the PTO is in operation.

Note: The optional PTO dedicated switches provide input information to the VMCU only. The VMCU cannot provide a signal to engage a PTO.

Note: In general, a front engine-mounted PTO does not require speed or engagement information to the VMCU except for those instances where the engine speed must NOT be lowered during PTO operation. As an example, in concrete mixer applications when an increase in engine speed is required to rotate the barrel at a faster speed, PTO input to the VMCU is required and engine speed control must be enabled, otherwise, engine speed may either revert to low idle or may increase due to the lack of interaction with the engine management system.

Auto Neutral for I-Shift AMT-G

Auto neutral is now available on vehicles equipped with the new generation I-Shift AMT-G (TANP variant) .

This feature is offered on the following Volvo I-Shift options:

- I-Shift (Standard)
- I-Shift with Crawler Gears

Auto neutral will put the I-Shift transmission into neutral when the parking brake is set. Once the park brake is released, the shifter will need to be placed in drive (D) for the transmission to go back into gear.

Auto neutral improves jobsite safety for a variety of applications such as mixers where remote throttle is often utilized.

Auto neutral can be enabled via the parameter (P1NFD = True) setting in Premium Tech Tool (PTT). If parameter (P1NFD) is not visible in Premium Tech Tool contact Body Builder Support @ 877-770-7575.

Supplier PTO/Pump Literature

Refer to the appropriate PTO/pump manufacturer's literature for all additional PTO/pump information, specifications, and installation procedures.

Parker Chelsea

Contact Paker/Chelsea at 662-895-1011 for PTO/pump literature or visit the following site:

- www.parker.com/chelsea

V O L V O

Volvo Trucks North America

<http://www.volvotrucks.com>