



Electrical, Electronic Control Unit (ECU) VN(4) Section 3

Introduction

This information provides details for the electronic control unit (ECU) applications for Volvo vehicles.

Note: For basic operator information, refer to the Operator's Manual.

Note: We have attempted to cover as much information as possible. However, this information does not cover all the unique variations that a vehicle chassis may present. Note that illustrations are typical but may not reflect all the variations of assembly.

All data provided is based on information that was current at the time of release. However, **this information is subject to change without notice.**

Note that no part of this information may be reproduced, stored or transmitted by any means without the written permission from Volvo Trucks North America.

Contents:

- "ISO 26262 Functional Safety Manual", page 4
- "Abbreviations", page 5
- "Routing and Clipping Guidelines", page 8
- "Battery Cable Guidelines", page 13
- "Battery Charging Guidelines", page 15
- "Ring Terminal Assembly", page 16
- "VNL Wiring Topology", page 18
- "Cab Pass-through Connectors", page 21
- "Body Builder Connectors", page 22
- "BodyLink IV", page 23
- "Electrical Receptacle 12v", page 26
- "Liftgate trailer connector usage recommendations", page 27
- "Auxiliary Switches location", page 28

- “Data Link Communication”, page 31
- “Vehicle Accessory Connector (RP1226)”, page 32
- “Vehicle Accessory Connector (RP1226) J1939 message support”, page 34
- “SAE J1939 Control Data Link (Backbone 1)”, page 46
- “SAE J2284 Diagnostic Data Link”, page 47
- “ISO 14229 Data Link”, page 47
- “Diagnostic Connector”, page 48
- “ECU Functions and Parameter Programming”, page 50
- “Engine Speed Control”, page 53
- “Engine Start/Shutdown Inputs”, page 59
- “Engine speed control through BodylinkIV”, page 61
- “Engine Speed Control Mode”, page 63
- “PTO Operation”, page 65
- “Remote PTO activation”, page 66
- “Body Builder Module”, page 67
- “Summary of adjustable BBM Parameters”, page 68
- “BBM Connectors”, page 68
- “FRC (Fuse and relay center)”, page 73
- “EFRC (External Fuse and relay center)”, page 79
- “12V Fuse holder”, page 77
- “12V/24V Chassis Fusebox”, page 82
- “BBEC (Body Builder Electrical Center)”, page 85
- “Front Chassis I/O Module (FCIOM)”, page 93
- “Trailer body I/O module (TBIOM)”, page 97
- “Center chassis I/O module (CCIOM)”, page 101
- “Rear chassis I/O module (RCIOM)”, page 106

- “Vehicle Master Control Unit (VMCU)”, page 112
- “Supplemental Restraint System”, page 119
- “Climate Control Module”, page 120
- “Instrument Cluster”, page 121
- “Exterior Light Control Panel”, page 122
- “Transmission Electronic Control Unit”, page 132

ISO 26262 Functional Safety Manual

Scope

This section describes the functional safety aspects related to the interface between the vehicle and the body builder equipment.

Introduction

ISO 26262 is the functional safety standard for road vehicles. Functional safety addresses safety-related functionality implemented in electronics and software. Volvo Trucks has during 2018 initiated development of new vehicle functions and systems according to ISO 26262 after the standard became applicable to trucks, buses and trailers. Before ISO 26262, Volvo Trucks followed other internal processes addressing functional safety.

The truck will gradually be made compliant to ISO 26262. However, it will take several years until the complete truck is compliant to the standard.

The status of the truck related to functional safety with regards to ISO 26262 will be described in this section. Continuous updates will be made to reflect the current status of the truck.

The ASILs of the body builder interface characteristics will be documented and it will be described in which sense the interfaces meet the different ASILs. This section will also contain information on requirements and constraints for the usage of the body builder interface. In case specific safety measures have to be applied by the body builder, this shall be stated in this section.

When a body builder needs anything that is not described or when the ASIL of the characteristic is not according to the body builders expectations, the body builder shall contact Volvo Trucks for guidance. This section will be referenced from other body builder sections when applicable.

Security disclaimer

It is the responsibility of the body builder to ensure adequate cybersecurity of the bodywork electronics equipment added to the vehicle e.g., the integrity and authenticity of any wireless data communication.

The body builder is also responsible to fulfil UN R155 vehicle type approval work (when applicable considering national regulations) for additional electronics added to the vehicle. Also note that Volvo UN R155 approval for the base vehicle is not valid if non-supported data communication network connections are used, see warning below.



WARNING

It is strictly forbidden to connect additional devices to internal data communication networks (CAN, LIN, Ethernet etc.). This could severely affect the drivability of the truck. Volvo only allows data communication network connections for bodywork devices on the dedicated external data communication connectors that are intended for it. All other connections or methods of access to the internal data communication networks are prohibited.

Abbreviations

Acronym	Description
CAN	Controller Area Network
ECU	Electronic Control Unit
LIN	Local Interconnect Network
SCIM	Security And Cab Interface Module
FAS	Front Active Steering
WSGW	Wireless Sensor GateWay
CCES	Chassis Camera Ethernet Switch
DACU	Driver Assistance Control Unit
VMCU	Vehicle Master Control Unit
BBM	Body Builder Module
IC	Instrument cluster
EBS	Electronically-controlled Brake System
ECM	Engine Control Module
TCM	Transmission Control Module
ACM	After-treatment Control Module
TBIOM	Trailer Body Input Output Module
APM	Air Production Modulator
BPMU	Battery Power Management Unit
DDM	Driver Door Module
PDM	Passenger Door Module
RCIOM	Rear Chassis Input Output Module
CCIOM	Center Chassis Input Output Module
FCIOM	Front Chassis Input Output Module
SRS	Supplementary Restraint System
LECM	Living Environment Control Module
CCM	Climate Control Module
DECM	Driver-Environment Control Module
TGW	Telematics GateWay
REM	Radio and Entertainment Module
SEM	Services and Entertainment Module
FLR	Forward-Looking Radar
FLC	Forward-Looking Camera
SID	Secondary Information Display
SWS	Steering Wheel Switches
DDCP	Driver Door Control Panel
PDCP	Passenger Door Control Panel

Acronym	Description
WAPD	Window Antipinch Driver
WAPP	Window Antipinch Passenger
SR	Side Radar
EPB	Electrical Parking Brake
TAS	Trailer Air Supply
HCU	Hand Control Unit
FSP	Flexible Switches Panel
ILCP	Interior Light Control Panel
ELCP	Exterior Light Control Panel
HVAC	Heating, Ventilation and Air Conditioning
PDC	Power Distribution Center

Notes

General Wiring Definitions

The general wiring definitions provides a standardized list of terminology used in running wires, hoses, and cables throughout the vehicle.

Abrasive Surface	Items capable of causing damage to the routed commodity in a rubbing condition during vehicle operation
AWG	American Wire Gauge
Bundled With	A number of items tied, wrapped, or otherwise held together
Cable Tie	A nylon plastic self-sizing strap, UV resistant, capable of bundling specified load(s) during vehicle operation
Chafing	To wear away by rubbing
Contacts	Items touching each other
Crimped	A routed commodity that is bent or pressed into ridges
Damaged	An item that differs from its original condition
Drooping	Routed items hanging downward, which are detrimental to safe vehicle operation
Dual Fall	(Pertaining to the Compressor Discharge Line) A high point in the routing of the Compressor Discharge Line (located on the engine) whereby any collected moisture is allowed to fall in two different directions where it is either dissipated by heat or is purged
High Current Electrical Cables	Wire sizes 13 mm sq. (0.5 inches sq.) (6 AWG) and larger
High Nut	Extended clamp length
Kinked	A tight bend, curl, or twist in the routed commodity causing flow to be restricted
Low Current Electrical Cables	Wire sizes 8 mm sq. (0.3 inches sq) (8 AWG) and smaller
Low Nut	Standard clamp length
Material Grade 30	Minimum yield strength of 30,000 psi
Material Grade 50	Minimum yield strength of 50,000 psi
Not Secured	Items not fastened, bundled or tied
Plastic Conduit	Corrugated or smooth wall tubing used to protect hoses, harnesses, cables, tubing, pipes, etc.
Puncture	Small hole or wound
Routed With	Items taking the same path but not attached to each other (i.e., parallel but separate)
Rubbing	Items that contact each other and have independent movement
Sharp Edge	A surface capable of cutting or piercing the routed commodity during vehicle operation
Twisted	Distorted from the routed commodities' original shape about it's cross-sectional center line
Touch	Items that contact each other but do not have relative movement

Note: Accessory electrical circuits should always be fused. Where possible, use the designated spare fuses or circuit breakers that are already supplied. Never overload the circuit beyond the rated amperage of the fuse or circuit breaker. Inductive loads, such as motors, light bulbs, and relays, cause higher current draw (surge current) in electrical circuits during initial start-up or turn-on. These circuits may require slow-blow fuses or higher-rated fuses or circuit breakers. The installation of add-on circuits for the body installation may interfere with the proper operation of other vehicle electrical components. The body installer is responsible for ensuring the continued proper operation of all electrical systems on the vehicle concerning conducted or radiated signals from the installation.

Routing and Clipping Guidelines

- 1 Brackets used in routing and clipping should be Material Grade 50 or better to ensure sufficient clamp load when sharing joint connections with cross members or other structural members. This applies only to joint connections using a low nut. Brackets of Material Grade 30 are acceptable provided the shared joint is using a high nut. The area of the clip bracket under the bolt head must be at least as large as the bolt head itself.
- 2 Clips that scratch exterior mounting surfaces shall not be used (i.e., barbed/spring type) unless the material is non-corroding (i.e., plastic). Clips must have rust protection.
- 3 Clip sizes should adequately secure the bundle without restricting flow, causing collapse, or preventing relative movement.
- 4 Bundles must be supported at a maximum interval of 18 inches (450 mm). A cable tie must be used between clipping points on bundles. When air and electrical lines are bundled together, the commodity with the greater cross sectional area may determine the support spacing. A minimum of two cable ties shall be used between clip points to bundle electrical lines when the larger interval is used.

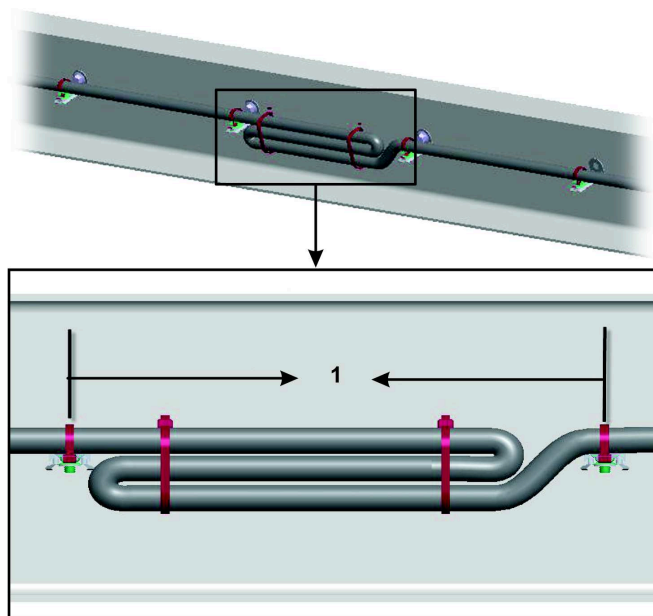

W3104131

1 Support electrical cables every 18 inches (450 mm)

Support Distances, Continued

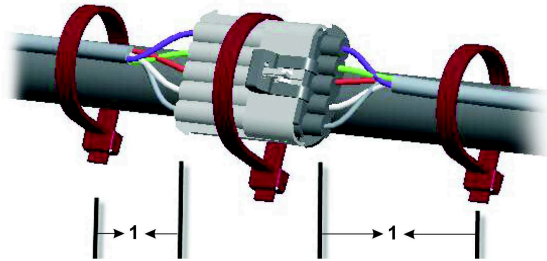

W3104144

1 Support cables near connectors every 4 inches (100 mm)

- 1 Electrical cables and wiring harnesses are to be secured 4 inches (100 mm) from the wire insertion end of the connector or clipped to the body.
- 2 Routing and clipping on purchased components (i.e., engine/transmission) should not include removing or replacing a bolt(s), nut(s) or screw(s) installed by the manufacturer. In such cases where this is unavoidable, the bolt(s), nut(s) or screw(s) shall be re-installed to the manufacturer's specifications.
- 3 Bundles should not contact sharp edges of cross members. Contact may occur if it is against a smooth surface, a smooth radiused edge or a coined edge and the bundle is secured to prevent independent movement.
- 4 Hoses, tubing, pipes and electrical conduits shall not rub each other but may touch.
- 5 The fabric braided portion of the compressor discharge hose is compatible to be bundled with all routed air lines.
- 6 The compressor discharge pipe shall be routed independent of all other routing.
- 7 Electric cables/harnesses must not be bundled with fuel or hydraulic lines. The electrical cables/harnesses may be routed parallel with fuel or hydraulic lines, however must remain separated by approved clipping materials. When design control is possible, electrical cables/harnesses will be routed above fuel or hydraulic lines. If fuel or hydraulic lines must route above circuit protected electrical cables/harnesses, the fuel or hydraulic lines will have no fittings or potential leak points above electrical cables/harnesses and shall be minimized to the shortest distance possible over low current electrical cables/harnesses.
- 8 All associated markings on air and electrical harnesses should have a corresponding clipping apparatus.
- 9 Critical clipping locations shall be designated on the component to insure proper placement in the vehicle (i.e., tape).
- 10 Maximum support distance for compressor discharge rigid pipe, 30 inches (762 mm). Pipe to be isolated from support brackets (i.e. rubber isolator).
- 11 Maximum support distance for compressor discharge flex hose, 24 inches (600 mm).
- 12 Compressor discharge line should have a constant fall from compressor to air dryer. A dual fall is allowable provided it occurs on the engine and within 24 inches (600 mm) of the compressor.
- 13 Maximum allowable dip in compressor discharge pipe/hose is one half the outer diameter of the pipe/hose. Preferred routing should have no dips in any of the routings. This is to avoid line blockage due to water collecting and freezing in the line.

Heating Specifications

In order to maintain the integrity of the cables and hoses, observe the following specifications for routing near a heat source.

Cable, hose, or harness type	Specification
Electrical cables and wiring harnesses	5 inches (130 mm) in all directions from turbocharger, exhaust components, and other high heat components
Unprotected hoses, tubing, harnesses, and cables	6 inches (150 mm) above, 5 inches (130 mm) beside and 4 inches (100 mm) below
Hoses, tubing, harnesses, and cables protected by reflective heat sheathing	3 inches (76 mm) above, 2 ½ inches (63,5 mm) beside and 2 inches (51 mm) below
Silicone transmission coolant hoses	2 inches (51 mm) from exhaust manifold and turbo (with reflective heat sleeving), 1 inch (25 mm) from exhaust pipe
Hoses, tubing, harnesses, and cables protected by a heat shield (no reflective sheathing)	3/8 inch (10 mm) between the component and the heat shield. (Not valid for fuel lines)
Refrigerant suction hoses	8 inches (200 mm)

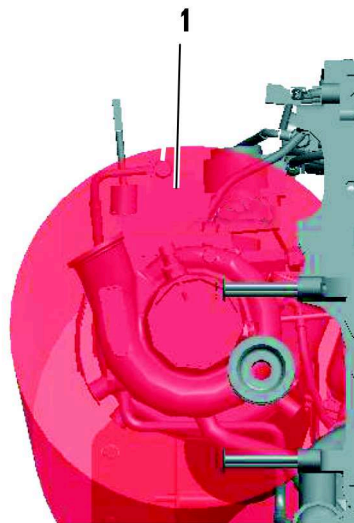

W3109897

1 Heat Radius from the Turbocharger, Front: 5 inches (130 mm)

Clipping Guidelines

Clipping brackets should be designed and mounted to adequately support the bundle. Clips should be mounted in a hanging position or supported along three-quarters of the horizontal mounting surface. Orientations that do not conform to the illustrations shall be tested.

- 1 When hoses, wires, and cables cross one another, secure them with a clamp. This prevents the sawing motion that could abrade them.
- 2 When routing flex hoses that are bent in two planes, clip them to prevent twisting. Clamp the hose at the point where the hose changes planes. The clamp has the effect of dividing the hose into two assemblies. If the section of the hose is bent in the same plane as the movement, the bend will absorb the movement and the hose will not twist.

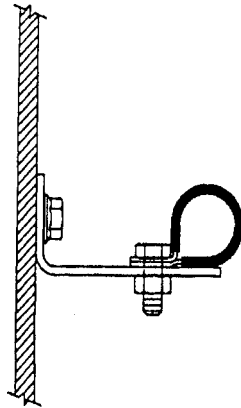

ACCEPTABLE

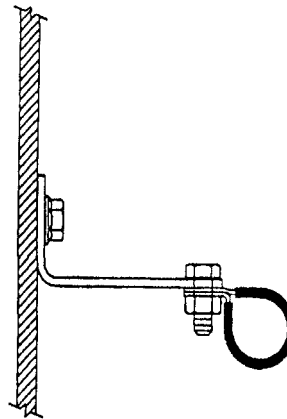

NOT ACCEPTABLE

W3103550

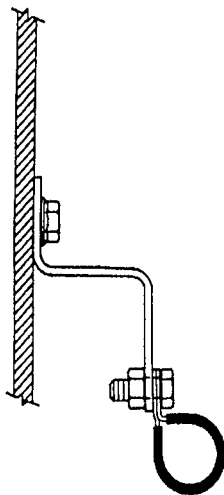

ACCEPTABLE

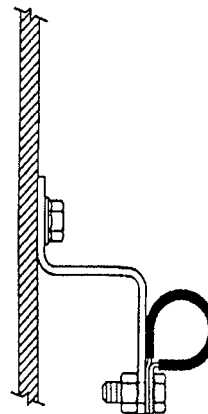

NOT ACCEPTABLE

W3103553

When routing connectors with cable ties, ensure the cable ties do not contact the connector locking tab. Cable ties should also not contact the bare wire.

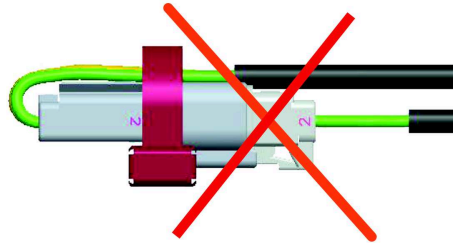
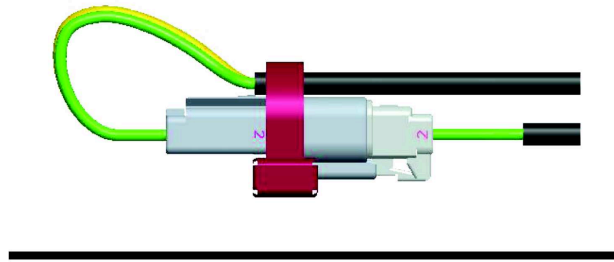

W3104148

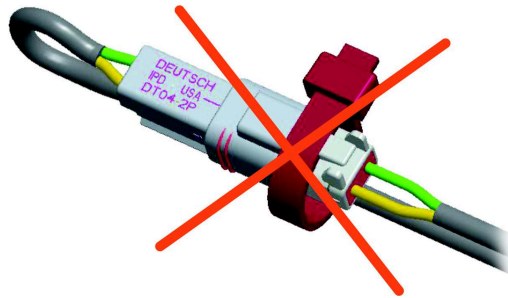
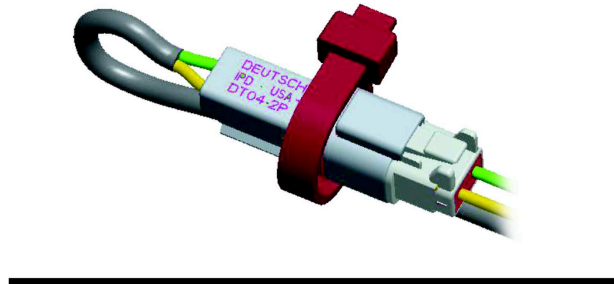

W3104149

Battery Cable Guidelines

The battery cable guidelines prevent electrical interference that can occur from improperly routed cables. In addition, the guidelines prevent cable damage through abrasion.

- 1 Battery cables with standard SAE stranding shall be supported at 16 inches (400 mm) maximum intervals. A separator type cable tie or an independent separator with cable tie may be used between clip points. No relative movement may occur between cables. If two (2) cable separators are used, they are to be installed equidistant from each other and arranged on a straight line, a maximum span between clip points of 24 inches (600 mm) may be used.
- 2 Strain relief clipping shall be provided for the battery and starter motor terminals. The strain relief clip shall be located with no relative motion to the terminals. The strain relief clip should be located close to these terminals and shall be within 20 inch (500 mm) cable length to the starter terminals.
- 3 Grommets shall be installed at points where cables pass through sheet metal or frames.
- 4 Routing shall avoid exposed edges of frame members, abrasive surfaces, and all sharp edges. When routing inside the frame, ensure that no contact with the frame is made with uncovered cables. Uncovered battery cables, external of the battery box, shall be routed independent of all other conduits. Covered cables may be bundled with other similarly covered conduits and air piping with a secured separator. **Do not route with/under fuel lines.**
- 5 Cables should be clipped as close as possible to all cable bends.
- 6 Battery cables shall not be located within 5 inches (130 mm) of engine exhaust related components or other heat sources without heat coverings or heat shielding. Testing shall be performed to determine effects of closer allowances and the use of heat shields. Battery cables should not be installed in any area directly above engine exhaust related components.
- 7 Where cables flex between moving parts, the last supporting clip shall be securely mounted such that relative movement does not promote chaffing.
- 8 Battery cables shall not support any mechanical loads other than their own mass.
- 9 Minimum bend radii of battery cables should be three times the cable diameter (2) for standard SAE strand cable.

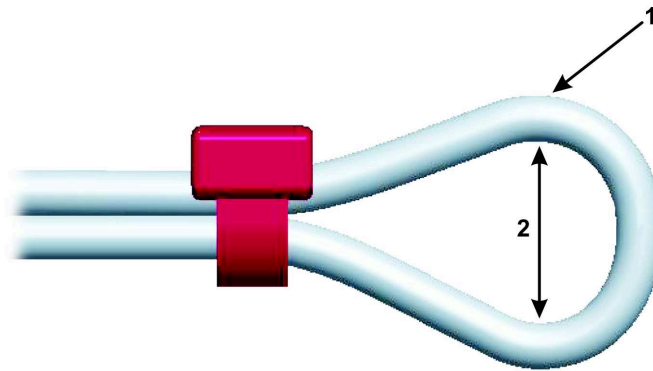

W3104133

1 Tube Diameter

2 Circle Diameter (2 x Cable Diameter)

Battery Guidelines, Continued

- 1 Star washers must not be used on electrical connections including grounds.
- 2 Asphalt type loom shall not be used for battery cable protection applications.
- 3 Battery cables shall not rub each other or surrounding items, but may touch when all items have no independent movement. Uncovered battery cables may not touch each other outside the battery box.
- 4 All exposed exterior circuit ends must be coated with a protective dielectric coating, as specified in the engineering documentation. If a wiring harness is required to be in an area of exposure, it must be approved by the appropriate wiring engineer.
- 5 Clip orientations should be per illustration or installation drawings utilizing compression or heavy duty clip.
- 6 Plastic conduit may be bundled and cable tied with covered battery cables when all items have no independent movement with each other. Battery cables may touch each other, plastic conduit or the battery, inside the battery box.
- 7 Covered battery cables may be securely tied or clamped to each other if no independent movement exists. Cables attached to the same terminal stud may be tied or clamped to each other.
- 8 First, position and install the battery cable ends at the starter motor posts. Next, assemble the engine harness terminals. Starter terminals that come with the starter may be first on the starter studs. Terminals shall not be reconfigured or bent.
- 9 When placing the frame bolt, adjacent to the battery box, the threaded end of the screw or bolt should face away from the battery box and any related cables. Wrench grip type bolts should not be used in the frame at the battery box area. Non-wrench grip type bolt or screw threaded ends may face towards the battery box only if clip bracketing or shielding is provided to prevent any possible cable contact with frame mounted hardware. Bolts that mount the battery box to the frame may be oriented toward the battery box.
- 10 Added abrasion protection should be used where the cable contacts other routed commodities or surfaces with no independent movement such as frame rail surfaces or transmission and engine castings. Polyethylene, polypropylene, nylon conduit and thick wall heat shrink tubing may be used for added abrasion protection.
- 11 Cables should be located to afford protection from road splash, stones, abrasion, grease, oil and fuel. Cables exposed to such conditions should be further protected by either, or a combination of, the use of heavy wall thermoplastic insulated cable, additional tape application, plastic sleeve or conduit.
- 12 Anytime an existing fastener is used to secure a clipping bracket (or any similar device), the fastener shall be re-torqued to the value specified in the original documentation given for the fastener.
- 13 Each exposed exterior circuit end must be coated with a dielectric protective coating. Thickness to be 0.13 – 0.3 inches (3.5 – 7 mm) wet, full coverage, 3 inches (76.2 mm) diameter.
- 14 Do not use box clamps to secure battery cables.
- 15 In addition to Behringer clamps, use double-head tie clamps.

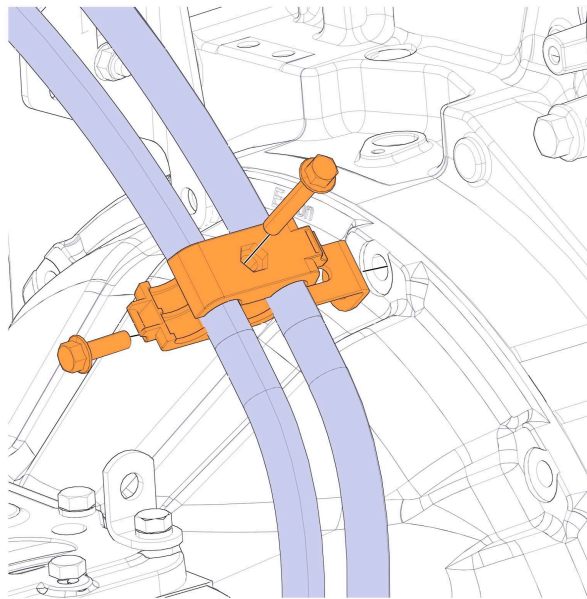

W3077595

Behringer clamps are recommended for securing battery cables to each other.

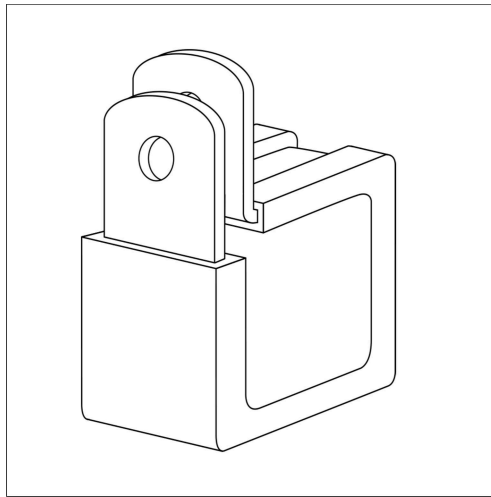

W3105372

Box Clamps (shown above) are NOT to be used for securing battery cables to each other.

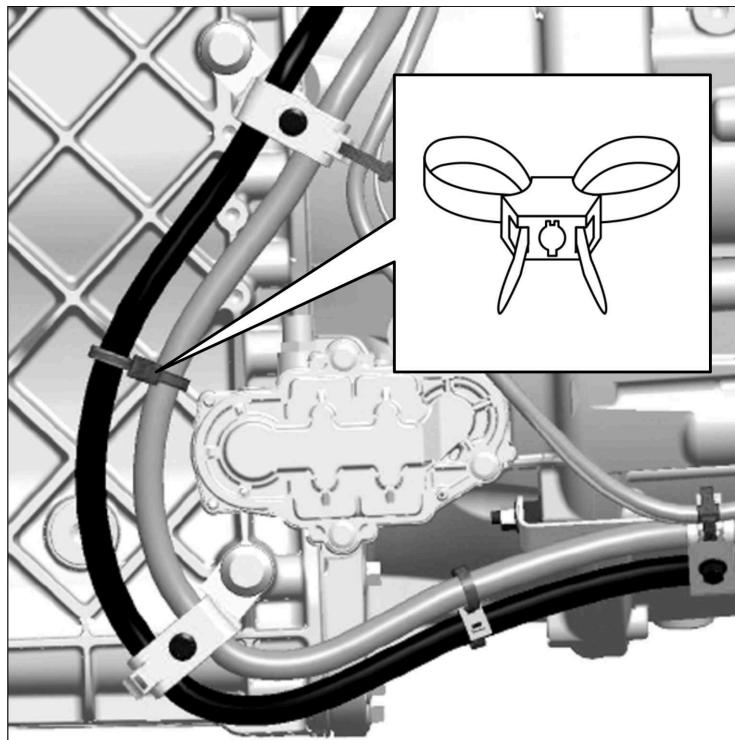

W3105374

Double-head tie clamps may be used to route battery cables.

Battery Charging Guidelines

Note: Please refer to the Body builder instruction “Section - 0; Body Builder, General Guidelines and Certification, Jump Charging”, for information on 12V and 24V battery charging.

Ring Terminal Assembly

Assemble terminal carrying the highest current (largest gauge wire) first, then graduate to the smallest gauge up to the fastener. Use a maximum of three (3) terminals per stud (unless otherwise specified on an illustration drawing).

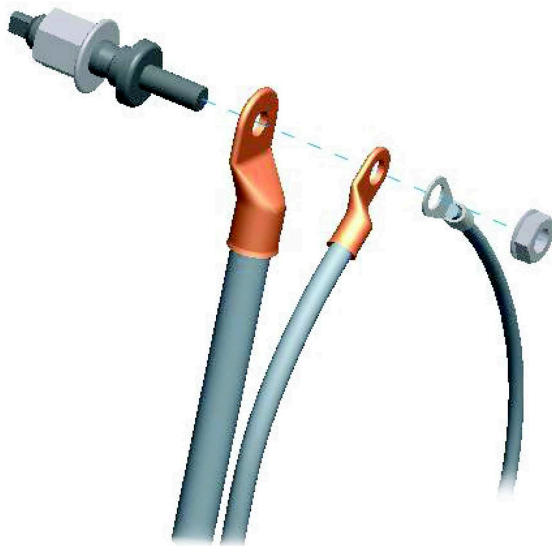

W3104152

When attaching ring terminals with a fastener, tighten the fastener to appropriate torque so that the contact area will touch the terminal at any point, in a full circle that is part of the terminal.

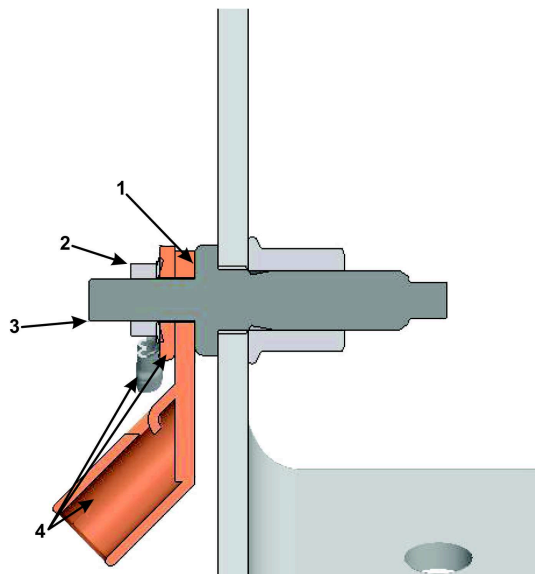

W3104153

- 1 Contact Area
- 2 Fastener
- 3 Stud
- 4 Terminals

When attaching multiple terminals, position the terminals at an angle to allow maximum contact of the terminal surface. Terminals are not allowed to bend other than their natural form. Terminals may be stacked back to back.

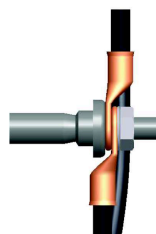
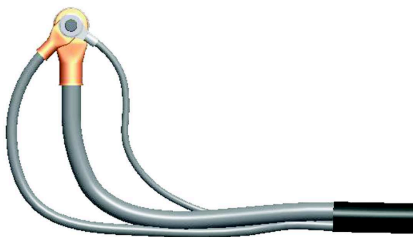

W3104154

Improperly fanned terminals result in unacceptable bends.

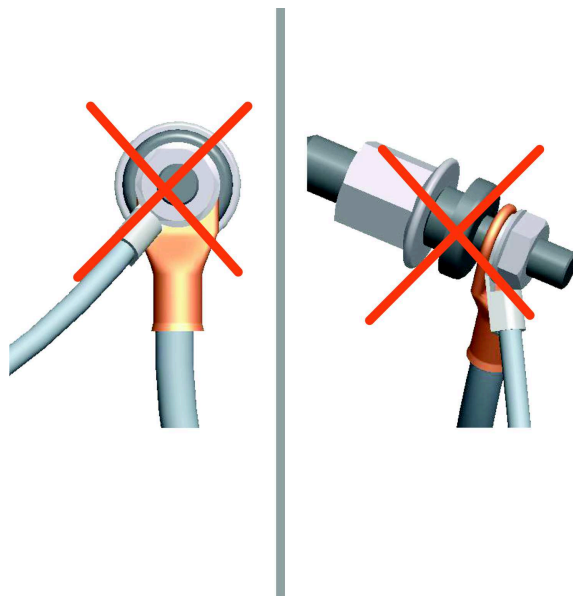

W3104155

VNL Wiring Topology

TEA2+ Topology

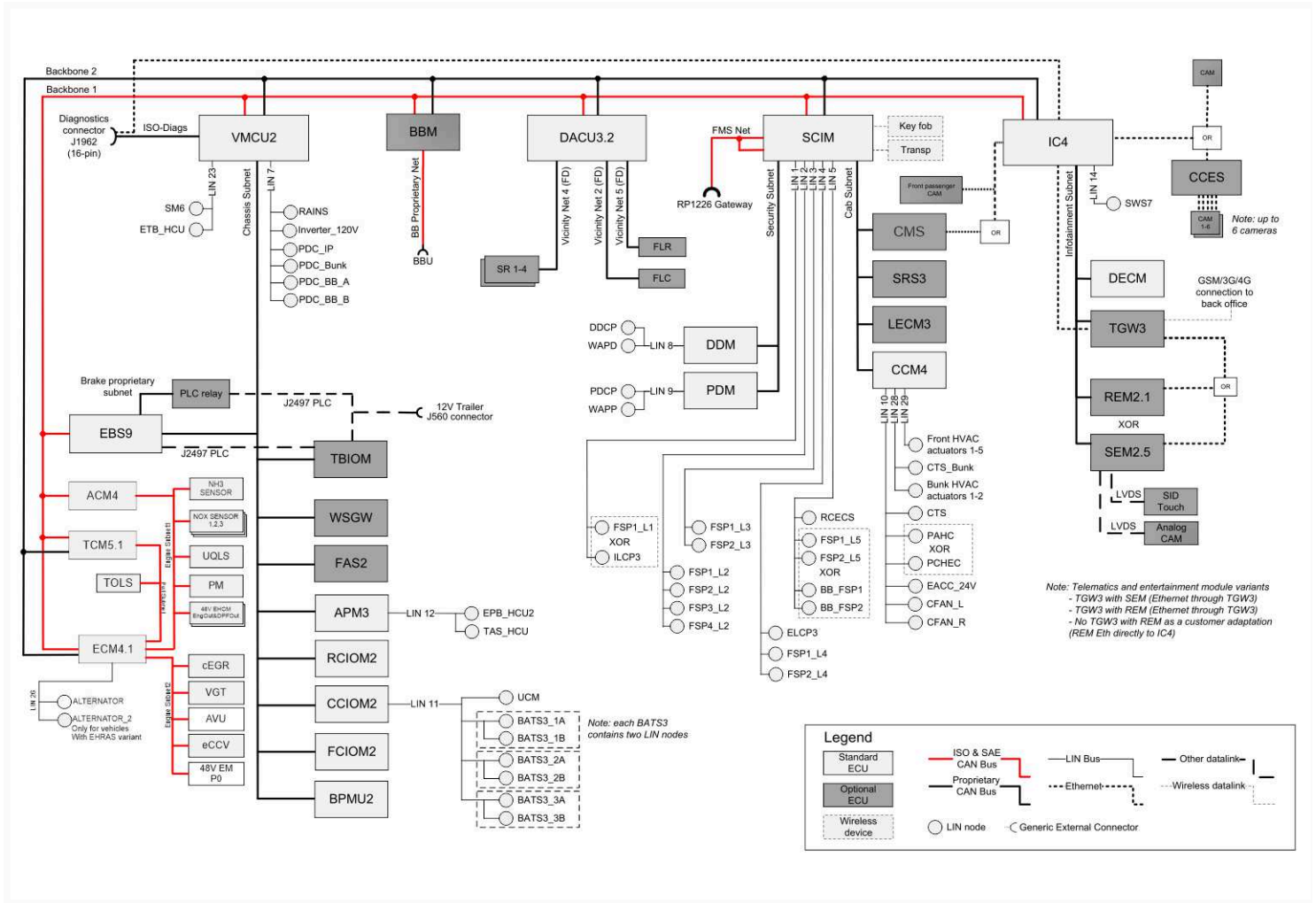

T3217321

Notes

Abbreviations

Acronym	Description
AVU	Air Valve Unit
ACM	After-treatment Control Module
APM	Air Production Modulator
BBM	Body Builder Module
BBU	Body Builder Unit
BPMU	Battery Power Management Unit
CAN	Controller Area Network
CCES	Chassis Camera Ethernet Switch
CCIOM	Center Chassis Input Output Module
CCM	Climate Control Module
CCV	Crank Case Ventilation
CMS	Camera Monitor System
CTS	Cab Temperature Sensor
DACU	Driver Assistance Control Unit
DDCP	Driver Door Control Panel
DDM	Driver Door Module
DECM	Driver-Environment Control Module
EACC	Electric Air Conditioner Compressor
EBS	Electronically-controlled Brake System
ECM	Engine Control Module
ECU	Electronic Control Unit
EGR	Exhaust Gas Recirculation
ELCP	Exterior Light Control Panel
EPB	Electrical Parking Brake
FAS	Front Active Steering
FCIOM	Front Chassis Input Output Module
FLC	Forward-Looking Camera
FLR	Forward-Looking Radar
FSP	Flexible Switches Panel
HCU	Hand Control Unit
HVAC	Heating, Ventilation and Air Conditioning
IC	Instrument Cluster
ILCP	Interior Light Control Panel
LECM	Living Environment Control Module
LIN	Local Interconnect Network
NH3_Sensor	Ammonia sensor
NOX	Nitrogen Oxides

Acronym	Description
PAHC	Parking Air Heater Cab
PCHEC	Parking Coolant Heater Engine Cab
PDC	Power Distribution Center
PDCP	Passenger Door Control Panel
PDM	Passenger Door Module
RCECS	Remote Control for Electronically Controlled Suspension
RCIOM	Rear Chassis Input Output Module
REM	Radio and Entertainment Module
SCIM	Security And Cab Interface Module
SEM	Services and Entertainment Module
SID	Secondary Information Display
SM	Stalk Module
SR	Side Radar
SRS	Supplementary Restraint System
SWS	Steering Wheel Switches
TAS	Trailer Air Supply
TBIOM	Trailer Body Input Output Module
TCM	Transmission Control Module
TGW	Telematics GateWay
TOLS	Transmisson Oil Level Sensor
UCM	Update and Configuration Management
VGT	Variable Geometry Turbo
VMCU	Vehicle Master Control Unit
WAPD	Window Antipinch Driver
WAPP	Window Antipinch Passenger
WSGW	Wireless Sensor GateWay

Notes

Cab Pass-through Connectors

The Cab Passthrough Module contains five connectors, located under the bonnet on the left-hand (LH) side of the truck. The CPT provides a pass-through from the engine side to the inside of the dashboard on the cab side.

Note: Only the XC202 connector has pins for the body builder. It is recommended not to modify the other connectors.

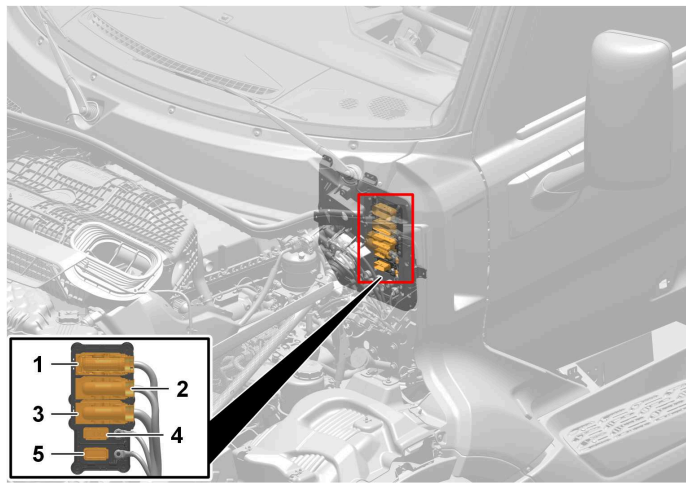

T3203327

Fig. 1 Option Connectors, Driver Side Engine Compartment

- 1 XC202
- 2 XC203
- 3 XC201
- 4 XC211
- 5 XC204

Notes

Body Builder Connectors

Connector and Gender Information

Note: Only the XC202 connector is applicable for the bodybuilder; the other connectors must not be modified.

Connector Series	Gender On-Vehicle
XC202	Female Terminals
XC203	
XC201	
XC211	
XC204	

Body builder cab pass through connections

With BBCHAS4 variant

CPT	BBM	Description
XC202:13	B2:3	Park brake
XC202:9	B1:2	PTO2 Request
XC202:10	B1:1	PTO1 Request
XC202:11	B1:4	Speed On/Off
XC202:4	B1:29	Not assigned
XC202:3	B1:30	Not assigned
XC202:14	B1:6	ESC Decrease
XC202:15	B1:5	ESC Increase
XC202:16	B1:3	Speed Control Mode 1

Note: For the BBMO-PK variant, only the CPT pinning is relevant. The wiring present in the connector is intended to assist with the BBM installation in the future.
For BBCHAS4 Variants, the pinning from BBM table is applicable.

Notes

BodyLink IV

BodyLink IV is a body builder electrical interface, which has a 29-pin electrical quick-connector (female connector). A male connector and pins are included with BodyLink IV supplied in the cab with the sales and service literature packets.

Note: The BodyLink IV back of cab connector is supplied with the mating connector housing and terminal pins from the factory. If additional pins or connectors are required, they can be purchased from your local Volvo Dealer. The female housing-connector part number is 22236186 and the male housing-connector part number is 22236185.

Variants for Body Connections

Item	KOLA variant	Model	Status	Description
BodyLink IV w/29-PIN connector	BBCHAS4	VNL	Option	29-pin under-cab connector, back of cab label, female connector, cab pass-through.
Aux output w/3-Pin connector	BBCHAS7	VNL	Option	3-pin under-cab connector, back of cab label, female connector, TBIOM Supply

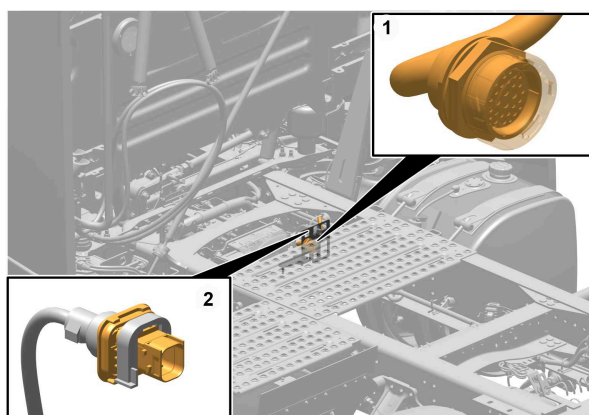

T3215593

- 1 BBCHAS4 (Bodylink IV)
- 2 BBCHAS7

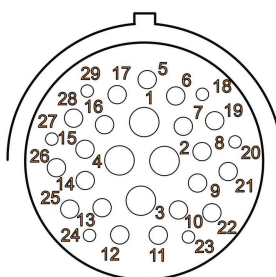

W3064928

VNL BodyLink IV 29-pin Connector, female Side of Connector

Pinning for BodyLink IV 29-pin Connector

Pole	Description
1	Battery power (30A)
2	Ignition power (30A)
3	Stop lamp(10A)
4	Taill/marker lamp(10A)
5	Reverse signal (15A)
6	LH turn(5A)
7	RH turn(5A)
8	AUX switch #1 (IGN) (12A Cont) ¹
9	AUX switch #2 (BATT) (15A Cont) ¹
10	AUX switch #3 (IGN) (12A) ¹
11	AUX switch #4 (IGN) (15A) ¹
12	-
13	-
14	-
15	Parking brake
16	NEUTRAL SIGNAL
17	-
18 (12v positive)	PTO #1 DIH (INPUT)
19 (12v positive)	PTO #2 DIH(INPUT)
20 (12v positive)	ESC control ON/OFF (INPUT)
21	BB CAN H
22	BB CAN L
23 (12v positive)	ESC SET/DECEL (INPUT)
24 (12v positive)	ESC RESUME/ACCEL (INPUT)
25 (12v positive)	ESC selector 1 (INPUT)
26 (12v positive)	PTO active (OUTPUT)
27	LH Turn/Stop (5A)
28	-
29	RH Turn/Stop (5A)

¹ Applicable based on Flexible switch variants, refer "Auxiliary Switches location", page 28

Flexible AUX switch connector

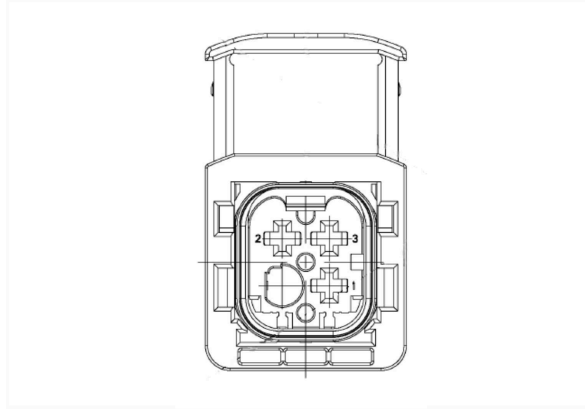

T3215594

VNL BBCHAS7 3-pin Connector, female Side of Connector

Mating Connector Details

Connector – 21106105 (TE 1-1418390-1)

Terminal- 983020 (TE 1-968876-3)

Pinning for BBCHAS7 3-pin Connector

Pole	Description
1	Auxiliary 1 (Digital output) ¹
2	Auxiliary 2 (Digital output) ¹
3	Ground

¹ Applicable based on flexible switch variants. For more information, refer “Auxiliary Switches location”, page 28

Electrical Receptacle 12v

SAE J560 is the standard electrical interface for truck trailers, used for trailer lighting, trailer ABS and auxiliary power supply. It consists of a 7-pin electrical quick connector located near the BOC.

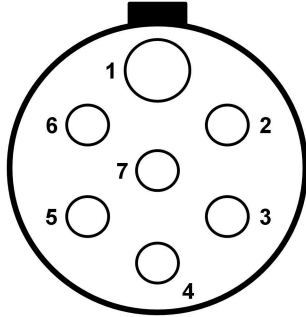

T3204870

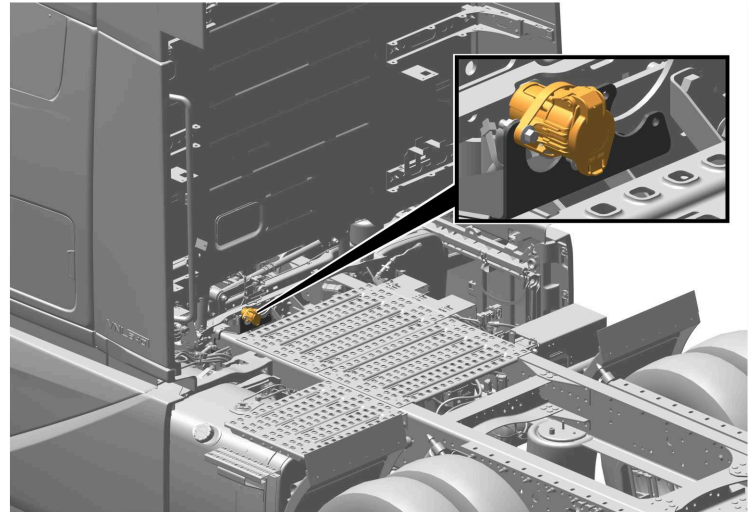

T3204858

VNL SAEJ560 7-pin Connector

Pin No.	Description
1	Ground
2	Position light, side marker
3	Left turn
4	Brake lights
5	Right turn
6	Tail lights, license plate
7	Auxiliary ABS power

Liftgate trailer connector usage recommendations

Scope

This section outlines the safety aspects concerning the interface between the trailer connector installed in the vehicle and the body builder equipment.

The trailer connector is located in the truck, either at the back of the cab or at the end of the frame.

The truck-side wiring harness and components can handle a maximum of 100A without any issues before the circuit breaker trips.

Recommendations

- The size of the wiring harness in the trailer side must be compatible with the wiring harness in the truck side. By default, the truck wiring harness is a 2GA cable.
- The truck has a ground strap from the fifth wheel. This ground strap must be connected to the trailer frame to create a consistent ground path to prevent short circuits.
- Proper maintenance of the cables and connectors on the trailer side must be ensured to prevent corrosion, thus reducing the risk of intermittent short circuits.

Note: The location of the trailer connection receptacle may vary based on the truck variant, either at the back of the cab or at the end of the frame.

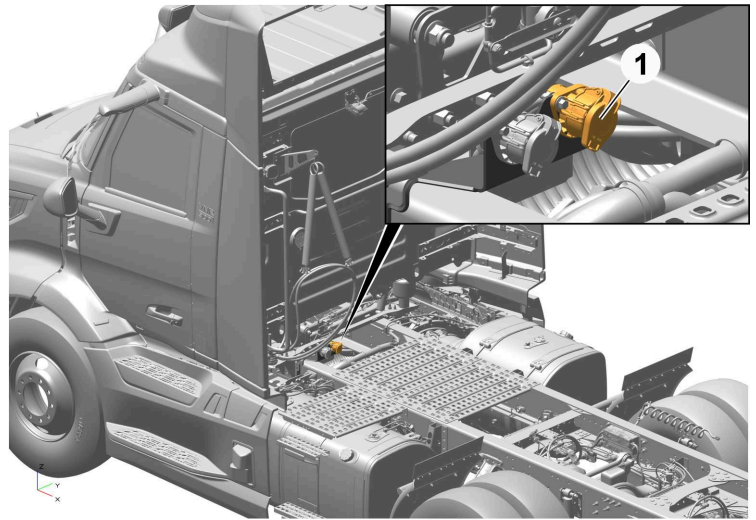

T3219589



WARNING

This trailer connector must be used only with the lift gate and to charge the trailer batteries. Usage for other power supply purposes, such as refrigeration is strictly prohibited as the wires are not designed to handle high loads.

Auxiliary Switches location

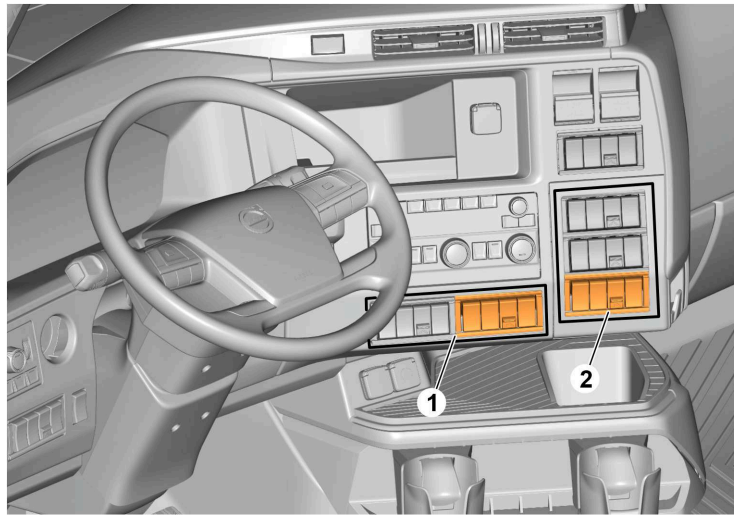

T3206031

1. Area 2 – Auxiliary switches
2. Area 3 – Auxiliary switches

Depending on which selection is made, there will be dash switches and chassis-mounted connectors ready for powering equipment.

There are two types of auxiliary switches available to the bodybuilder hardwired and flexible. Switches can be installed in both the dash and the back of the cab area. However, only switches in the dash will be pre-installed from the factory, while back of cab switches are aftermarket solutions.

The flexible auxiliary switches will be installed in Area 2 on the dash and will overflow into Area 3 if there are already other switches prioritized in those areas.

The Hardwired auxiliary switches will only be installed in Area 3.

Note: The flexible auxiliary switches can be accessed through the BBCHAS7 connector. Refer “Flexible AUX switch connector”, page 25 for pinning details.

Note: The hardwired auxiliary switches can be accessed through the back of cab connector based on the AUX switch variant as shown below:

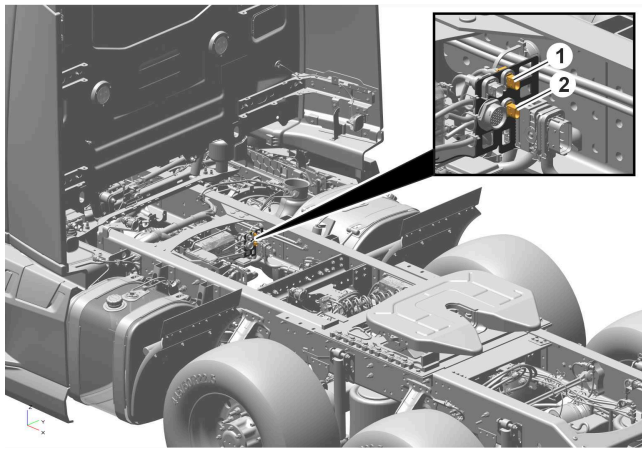

T3218143

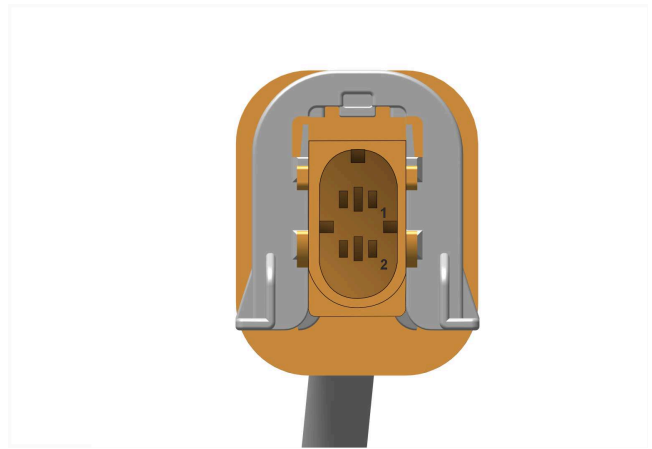

T3218144

Applicable variant

- 1 AUXSW-2
- 2 AUXSW-2, AUXSW-4

Pin Description

- 1 Power supply for AUX 1 and 2
- 2 Power supply for AUX 3 and 4

AUX Switch Wiring

Variant	Description
UAUXSW	WITHOUT AUX. SWITCH WIRING
AUXSW-2	WIRING FOR TWO AUX. SWITCHES
AUXSW-4	WIRING FOR FOUR AUX. SWITCHES

AUX electronic switch

Variant	Description
UAESW	WITHOUT AUX ELECTRONIC SWITCHES
AESW2B	ELECTRONIC SWITCHES 2 MONOSTABLE SWITCHES
AESW4	ELECTRONIC SWITCHES 4 MONOSTABLE SWITCHES

AUX flexible switch slot

Sales code/Variant	Description
UAFSS	WITHOUT AUXILIARY FLEXIBLE SWITCH SLOT
AFSS2	AUXILIARY FLEXIBLE SWITCH SLOT - 2
AFSS4	AUXILIARY FLEXIBLE SWITCH SLOT - 4

Parameters

Parameter code	Description	Min	Default value	Max
P1DI2 P1DI3 P1DI4 P1DI5 P1DI6 P1DI7	Monostable HMI logic for aux switches 1 to 6 Auxiliary Switch X, Switch Logic 0 = State based logic (the request follows the switch's state (BI-Stable)) 1 = Pulse based logic (the request is toggled on the closing transition (Monostable)) 2 = Event based logic (the request is set on the closing transition and reset on the opening transition)	-	1	-
P1ZVX	AuxSW10 configuration for Trailer AUX supply Allow Delayed Activation = true Enable Living = true Enable Accessory = true	-		-
P1ZWC	Aux output 12 Forced ON in pre-running and above except during cranking where it is forced OFF	-	1	-
P1ZWC	Aux output 12 Forced ON in living and above except during cranking where it is forced OFF	-	3	-

Bodybuilder Interface, Auxiliary Switch Output X, Switch Allocation, Configuration

Parameter code	Description	Min	Default value	Max
P1ZWD	Output to switches allocation for 12 V BBEC with BBCHAS4: AUXSW 2 and 4 - Aux outputs 1 and 2 (VMCU) AUXSW 1 and 3 – Aux outputs 9 and 10 (TBIOM)	-	2	-
P1ZWE		-	4	-
P1ZWF		-	0	-
P1ZWG		-	0	-
P1ZWK		-	1	-
P1ZWL		-	3	-
P1ZWO	Aux output 12 (TBIOM) is controlled by AuxSW10 (trailer aux supply)	-	10	-

DOID is the Output number on the ECU.

Value that is set in the DOID maps which AUX switch # in the dash will trigger the output.

Example:P1ZWD (AuxDO1 from VMCU) is set as 2, and will activate when Aux switch #2 is pressed.

General Information

The VNL contains many Electronic Control Units (ECUs) for operating many of the vehicle's functions. Most ECUs are linked together using one or more databuses for sharing information.

Some ECUs operate independently of each other, but most rely on interaction with other ECUs to properly perform their functions. For example, the Engine Control Module (ECM) depends on the Vehicle Master Control Unit (VMCU) to supply information on the in-cab controls and switches. Without this information, the engine will not operate properly.

All ECUs use some form of Input and Output devices to perform their functions. These devices may include switches, sensors, solenoids, and relays. **NEVER** tie or splice into a sensor or input device used by an ECU. This could affect the proper operation of the sensor. Likewise, never tie into an output device, which is controlled by an ECU, unless specifically authorized to do so elsewhere in this document.

Data Link Communication

Communication between the different ECUs take place through data links: SAE J1939, ISO J2284.

The instrument cluster, the engine control module (ECM), the VMCU and the data link connector (DLC) are always included in the system. The system may include other ECUs, depending on optional equipment.

For more information about the Diagnostic Connector (OBD 16) and the I/O pin locations(**“16 Pin Diagnostic Connector (OBD) pin definition”, page 49**)

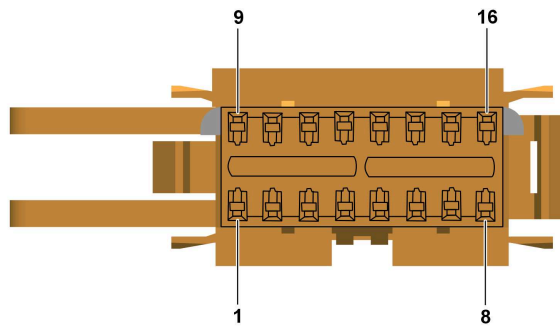

T3203331

16 Pin Diagnostic Connector (OBD 16)

Notes

Vehicle Accessory Connector (RP1226)

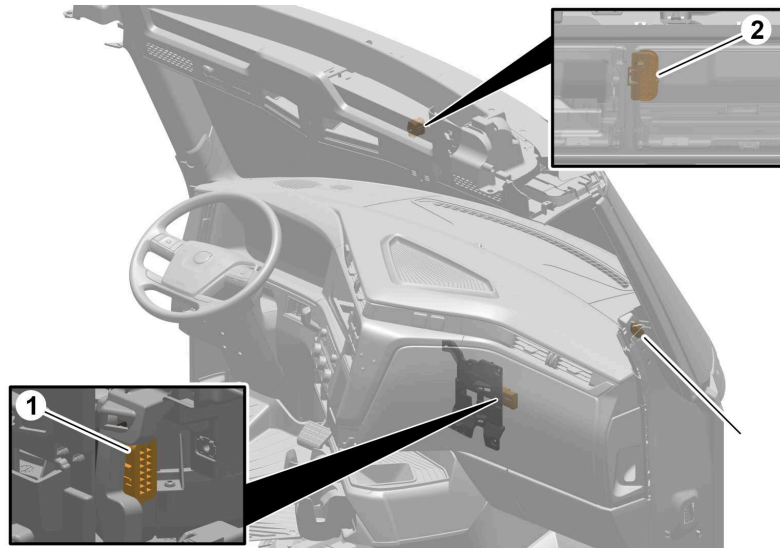

T3204510

RP1226 connectors

The purpose of vehicle accessory connector (TMC RP1226) is to connect the vendor device to the vehicle.

Volvo vehicle is equipped with two TMC RP1226 vehicle accessory connectors. One connector is located inside the dashboard, and another one is on the overhead panel.

The connectors are used to connect the aftermarket Fleet Management devices. Examples of these include telematics devices, data logging equipment, tire pressure monitors and electronic logging devices (ELDs) used for hours-of-service recording.

Notes

TMC RP1226 Connector

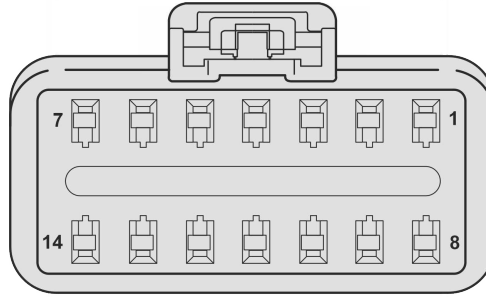

T3159520

Pin numbers	Description
1	+12 V After battery switch (10 A shared)
2	CAN-1 High
3	—
4	—
5	—
6	—
7	+12 V After ignition (10 A shared)
8	Ground
9	CAN-1 Low
10	—
11	—
12	—
13	—
14	+12 V Battery (10 A shared)

Vehicle Accessory Connector (RP1226) J1939 message support

The FMSnet CAN network provides vehicle data, such as engine, transmission, and electrical information, at the RP1226 interface. Devices that use J1939 vehicle data, such as electronic logging devices and logging devices, can use this interface. The system offers simplified communication between the SCIM and other related electrical systems. Multiple signals are sent over a single pair of twisted wires, as opposed to individual wires for each function. The J1939 data link is used to send these signals.

The benefit of this arrangement is fewer wires, sensors and connections are required for communication purposes between systems. Also, there is greater signal consistency and reliability.

The vehicle accessory connector (RP1226) uses the FMSnet via SCIM to relay messages from the CAN.

Note: For vehicles built after November 17, 2025, the OBD connector has the option to relay FMSnet messages via the SCIM.

Multiplexing Parameters

Message	Source address	Update Rate	SPN	Signal Names
TSC1 (PGN 0)	0x0B	100ms	518	Engine Requested Torque/Torque Limit
FLIC (PGN 43264)	0x31	100ms	3564	Lane Departure warning Enabled Command
CM1 (PGN 57344)	0x17	100ms	1856	Seat belt Switch
			3695	Aftertreatment Regeneration Inhibit Switch
			3695	Aftertreatment Regeneration Force Switch
ERC1 (PGN 61440)	0x0F	100ms	520	Actual Retarder - Percent Torque
			900	Retarder Torque Mode
			571	Retarder Enable - Brake Assist Switch
			572	Retarder Enable - Shift Assist Switch
			1717	Actual Maximum Available Retarder - Percent Torque

Message	Source address	Update Rate	SPN	Signal Names
EBC1 (PGN 61441)	0x0B	100ms	521	Brake Pedal Position
			561	ASR Engine Control Active
			562	ASR Brake Control Active
			563	Anti-Lock Braking (ABS) Active
			576	ASR Off-road Switch
			577	ASR "Hill Holder" Switch
			969	Remote Accelerator Enable Switch
			971	Engine Derate Switch
			973	Engine Retarder Selection
			1121	EBS Brake Switch
			1238	Traction Control Override Switch
			1243	ABS Fully Operational
			1438	ABS/EBS Amber Warning Signal (Powered Vehicle)
			1439	EBS Red Warning Signal
			1792	Tractor-Mounted Trailer ABS Warning Signal
			1793	ATC/ASR Information Signal
ETC1 (PGN 61442)	0x03	100 ms	161	Transmission Input Shaft Speed
			162	Transmission Requested Range
			191	Transmission Output Shaft Speed
			522	Percent Clutch Slip
			560	Transmission Driveline Engaged
			573	Transmission Torque Converter Lockup Engaged
			574	Transmission Shift In Process
			606	Engine Momentary Overspeed Enable
EEC2 (PGN 61443)	0x00	100 ms	29	Accelerator Pedal 2 Position
			91	Accelerator Pedal 1 Position
			92	Engine Percent Load At Current Speed
			558	Accelerator Pedal 1 Low Idle Switch
			559	Accelerator Pedal Kickdown Switch
			974	Remote Accelerator Pedal Position
			1437	Road Speed Limit Status

Message	Source address	Update Rate	SPN	Signal Names
EEC1 (PGN 61444)	0x00	100 ms	190	Engine Speed
			512	Driver's Demand Engine – Present Torque
			513	Actual Engine – Percent Torque
			899	Engine Torque Mode
			1675	Engine Started mode
			4154	Actual Engine – Percent Torque (Fractional)
ETC2 (PGN 61445)	0x03	100 ms	162	Transmission Requested Range
			163	Transmission Current Range
			524	Transmission Selected Gear
			526	Transmission Actual Gear Ratio
			523	Transmission Current Gear
FLI1 (PGN 61447)	0xE8	100ms	1700	Lane Departure Imminent, Left Side
			1701	Lane Departure Imminent, Right Side
			3565	Lane Departure Left
			3566	Lane Departure Right
			7473	Driver Alertness Warning
			8135	Right Side Lane Departure Optical Warning Command
			8136	Left Side Lane Departure Optical Warning Command
			8137	Right Side Lane Departure Acoustical Warning Command
			8138	Left Side Lane Departure Acoustical Warning Command
			9749	Right Side Lane Departure Haptic Warning Command
			9750	Left Side Lane Departure Haptic Warning Command
VDC2 (PGN 61449)	0x0B	100ms	1807	Steering Wheel Angle
			1808	Yaw Rate
			1809	Lateral Acceleration
			1810	Longitudinal Acceleration
			1811	Steering Wheel Turn Counter
EGF1 (PGN 61450)	0x31	100ms	132	Engine Intake air mass flow rate
AT1IG1 (PGN 61454)	0x00	100ms	3216	Engine Exhaust 1 NOx 1
AT1OG1 (PGN 61455)	0x00	100ms	3226	Aftertreatment 1 Outlet NOx 1
AEBS1 (PGN 61487)	0x31	100ms	5676	Forward Collision Advanced Emergency Braking System State
VP2 (PGN 64502)	0x31	100ms	8129	Horizontal Dilution of Precision

Message	Source address	Update Rate	SPN	Signal Names
VEP5 (PGN 64694)	0x31	100ms	5981	SLI Battery Pack State of Charge
CCVS3 (PGN 64732)	0x00	100ms	6809	Cruise control Set speed (High Resolution)
LFE2 (PGN 64737)	0x00	100ms	1600	Engine Fuel Rate (High resolution)
DLCD2 (PGN 64772)	0x31	100ms	5104	Vehicle Battery Voltage Low Lamp Data
HRLFC (PGN 64777)	0x00	100 ms	5054	Engine Total Fuel Used (High Resolution)
BCH1 (PGN 64789)	0x31	100ms	4993	Battery Charger 1 Output Current
BDS (PGN 64791)	0x31	100ms	4952	Driver Beltlock Status
			4953	Passenger Beltlock Status
A1SCREGT1 (PGN 64830)	0x00	100ms	4360	Aftertreatment 1 SCR Intake Temperature
			4363	Aftertreatment 1 SCR Outlet Temperature
GCW (PGN 64872)	0x31	100ms	417	Gross Combination Weight
AT1S1 (PGN 64891)	0x00	100 ms	3719	Aftertreatment 1 Diesel Particulate Filter Soot Load Percent
			3720	Aftertreatment 1 Diesel Particulate Filter Ash Load Percent

Message	Source address	Update Rate	SPN	Signal Names
DPFC1 (PGN 64892)	0x00	100 ms	3697	Diesel Particulate Filter Lamp Command
			3700	Aftertreatment Diesel Particulate Filter Active Regeneration Status
			3701	Aftertreatment Diesel Particulate Filter Status
			3702	Diesel Particulate Filter Active Regeneration Inhibited Status
			3703	Diesel Particulate Filter Active Regeneration Inhibited Due to Inhibit Switch
			3706	Diesel Particulate Filter Active Regeneration Inhibited Due to PTO Active
			3707	Diesel Particulate Filter Active Regeneration Inhibited Due to Accelerator Pedal Off Idle
			3708	Diesel Particulate Filter Active Regeneration Inhibited Due to Out of Neutral
			3709	Diesel Particulate Filter Active Regeneration Inhibited Due to Vehicle Speed Above Allowed Speed
			3710	Diesel Particulate Filter Active Regeneration Inhibited Due to Parking Brake Not Set
			3711	Diesel Particulate Filter Active Regeneration Inhibited Due to Low Exhaust Temperature
			3712	Diesel Particulate Filter Active Regeneration Inhibited Due to System Fault Active
			3714	Diesel Particulate Filter Active Regeneration Inhibited Due to Temporary System Lockout
			3715	Diesel Particulate Filter Active Regeneration Inhibited Due to Permanent System Lockout
3716	Diesel Particulate Filter Active Regeneration Inhibited Due to Engine Not Warmed Up			

Message	Source address	Update Rate	SPN	Signal Names
EOI (PGN 64914)	0x00	100ms	3607	Engine Emergency (Immediate) Shutdown Indication
PTODE (PGN 64932)	0x03	100 ms	3457	Engagement Consent – Transmission input shaft PTO 2
			3456	Engagement Consent – Transmission input shaft PTO 1
			3948	At least one PTO engaged
AT1IMG (PGN 64946)	0x00	100ms	3251	Aftertreatment 1 Diesel Particulate Filter Differential Pressure
AT1OG2 (PGN 64947)	0x00	100ms	3246	Aftertreatment 1 Diesel Particulate Filter Outlet Temperature
EBC5 (PGN 64964)	0x0B	100 ms	2912	Hill holder mode
			2917	XBR System State
			2918	XBR Active Control Mode
			3839	Brake Temperature Warning
OEL (PGN 64972)	0x17	100 ms	2872	Main Light Switch
			2874	High-Low Beam Switch
			2875	Hazard Light Switch
			2876	Turn Signal Switch
			2878	Operators Desired Back-light
OWW (PGN 64973)	0x17	100ms	2863	Front Operator Wiper Switch
MVS (PGN 64977)	0x31	100ms	2805	FMS-standard Requests Supported
			2806	FMS-standard SW-version supported.
FMS (PGN 64997)	0x31	100ms	2595	Applied Vehicle Speed Limit
LCMD (PGN 65089)	0x37	100 ms	2347	High Beam Head Light Command
			2349	Low Beam Head Light Command
			2367	Left Turn Signal Lights Command
			2369	Right Turn Signal Lights Command
			2371	Left Stop Light Command
			2373	Right Stop Light Command
			2375	Center Stop Light Command
LCMD (PGN 65089)	0x37	100 ms	2377	Tractor Marker Light Command
			2381	Tractor Clearance Light Command
			2385	Rotating Beacon Light Command

Message	Source address	Update Rate	SPN	Signal Names
VDC1 (PGN 65103)	0x0B	100 ms	1813	VDC Information Signal
			1814	VDC Fully Operational
			1815	VDC brake light request
			1816	ROP Engine Control active
			1817	YC Engine Control active
			1818	ROP Brake Control active
			1819	YC Brake Control active
			5624	Trailer – VDC active
BT1 (PGN 65104)	0x31	100ms	1800	SLI Battery 1 Temperature
VEP3 (PGN 65106)	0x31	100ms	2579	SLI Battery 1 Net Current (High Range/Resolution)
AT1T111 (PGN 65110)	0x3D	100 ms	1761	Aftertreatment 1 Diesel Exhaust Fluid Tank Volume
			3031	Aftertreatment 1 Diesel Exhaust Fluid Tank Temperature 1
FLI2 (PGN 65115)	0xE8	100ms	1702	Lane Departure Indication Enable Status
			1710	Lane Tracking Status Left Side
			1711	Lane Tracking Status Right Side
			7474	Driver Alertness Level
			7475	Driver Alertness Warning System State
			8139	Left Wheel Lane Departure Distance
			8140	Right Wheel Lane Departure Distance
			8141	Lane Departure Warning System State
			8142	Forward Lane Imager Status
HRW (PGN 65134)	0x0B	100ms	1592	Front Axle, Left Wheel Speed
			1593	Front axle, right wheel speed
			1594	Rear axle, left wheel speed
			1595	Rear axle, right wheel speed

Message	Source address	Update Rate	SPN	Signal Names
ACC1 (PGN 65135)	0x2A	100ms	1586	Speed of forward vehicle
			1587	Distance to forward vehicle
			1588	Adaptive Cruise Control Set Speed
			1589	Adaptive cruise control set distance mode
			1590	Adaptive Cruise Control Mode
			1591	Road curvature
			1796	ACC Distance Alert Signal
			1797	ACC System Shutoff Warning
			1798	ACC Target Detected
			5022	Forward Collision Warning
CVW (PGN 65136)	0x03	100ms	1585	Powered Vehicle Weight
			1760	Gross Combination Vehicle Weight
E11 (PGN 65170)	0x31	100ms	1241	Engine Fuel System 1 Gas Mass Flow Rate
EBC4 (PGN 65196)	0x0B	100ms	1099	Brake Lining Remaining, Front Axle, Left Wheel
			1100	Brake Lining Remaining, Front Axle, Right Wheel
			1101	Brake Lining Remaining, Rear Axle #1, Left Wheel
			1102	Brake Lining Remaining, Rear Axle #1, Right Wheel
			1103	Brake Lining Remaining, Rear Axle #2, Left Wheel
			1104	Brake Lining Remaining, Rear Axle #2, Right Wheel
			1105	Brake Lining Remaining, Rear Axle #3, Left Wheel
			1106	Brake Lining Remaining, Rear Axle #3, Right Wheel
EBC3 (PGN 65197)	0x0B	100ms	1091	Brake Application Pressure High Range, Front Axle, Left Wheel
			1092	Brake Application Pressure High Range, Front Axle, Right Wheel
			1093	Brake Application Pressure High Range, Rear Axle #1, Left Wheel
			1094	Brake Application Pressure High Range, Rear Axle #1, Right Wheel
			1095	Brake Application Pressure High Range, Rear Axle #2, Left Wheel
			1096	Brake Application Pressure High Range, Rear Axle #2, Right Wheel
			1097	Brake Application Pressure High Range, Rear Axle #3, Left Wheel
			1098	Brake Application Pressure High Range, Rear Axle #3, Right Wheel

Message	Source address	Update Rate	SPN	Signal Names
AIR1 (PGN 65198)	0x11	100 ms	1086	Parking and/or Trailer Air Pressure
			1087	Service Brake Circuit 1 Air Pressure
			1088	Service Brake Circuit 2 Air Pressure
GFC (PGN 65199)	0x11	100ms	1040	Total Fuel Used (Gaseous)
EBC2 (WSI PGN 65215)	0x0B	100 ms	904	Front Axle Speed
			905	Relative Speed; Front Axle, Left Wheel
			906	Relative Speed; Front Axle, Right Wheel
			907	Relative Speed; Rear Axle #1, Left Wheel
			908	Relative Speed; Rear Axle #1, Right Wheel
			909	Relative Speed; Rear Axle #2, Left Wheel
			910	Relative Speed; Rear Axle #2, Right Wheel
SERV (PGN 65216)	0x11	100 ms	914	Service Distance
VDHR (PGN 65217)	0x17	100 ms	917	Total Vehicle Distance (High Resolution)
			918	Trip Distance (High Resolution)
IO (PGN 65244)	0x00	100 ms	235	Engine Total Idle Hours
			236	Engine Total Idle Fuel Used
EEC3 (PGN 65247)	0x00	100ms	514	Nominal Friction – Percent Torque
VD (PGN 65248)	0x17	100 ms	244	Trip Distance
			245	Total Vehicle Distance
EC1 (PGN 65245)	0x00	100ms	544	Engine Reference Torque
SHUTDN (PGN 65252)	0x11	100ms	590	Engine Idle Shutdown Timer State
			592	Engine Idle Shutdown Timer Override
			593	Engine Idle Shutdown has Shutdown Engine
			594	Engine Idle Shutdown Driver Alert Mode
HOURS (PGN 65253)	0x00	100 ms	247	Engine Total Hours of Operation
			249	Engine Total Revolutions
TD (PGN 65254)	0x17	100 ms	959	Seconds
			960	Minutes
			961	Hours
			962	Day
			963	Month
			964	Year
			1601	Local minute offset
			1602	Local hour offset

Message	Source address	Update Rate	SPN	Signal Names
VH (PGN 65255)	0x11	100 ms	248	Total Power Takeoff Hours
VDS (PGN 65256)	0xEE	100ms	165	Compass Bearing
			517	Navigation-Based Vehicle Speed
			580	Altitude
LFC (PGN 65257)	0x00	100 ms	250	Engine Total fuel Used
VW (PGN 65258)	0x2F	100 ms	181	Cargo Weight
			582	Axle Weight
			928	Axle Location
VI (PGN 65260)	0x00	100 ms	237	Vehicle Identification Number
CCSS (PGN 65261)	0x00	100ms	74	Maximum Vehicle Speed Limit
ET1 (PGN 65262)	0x00	100 ms	110	Engine Coolant temperature
			175	Engine Oil Temperature 1
EFLP1 (PGN 65263)	0x00	100 ms	98	Engine Oil Level
			100	Engine Oil Pressure
			111	Engine Coolant Level 1
PTO1 (PGN 65264)	0x11	100 ms	187	Power Takeoff Set Speed
			980	Engine PTO Governor Enable Switch
			981	Engine PTO Governor Accelerate Switch
			982	Engine PTO Governor Resume Switch
			983	Engine PTO Governor Coast/Decelerate Switch
			984	Engine PTO Governor Set Switch
CCVS (65265)	0x11	100 ms	70	Parking Brake Switch
			84	Wheel-Based Vehicle Speed
			86	Cruise Control Set Speed
			527	Cruise Control States
			595	Cruise Control Active
			596	Cruise Control Enable Switch
			597	Brake Switch
			598	Clutch Switch
			599	Cruise Control Set Switch
			600	Cruise Control Coast (Decelerate) Switch
			601	Cruise Control Resume Switch
			602	Cruise Control Accelerate Switch
			976	PTO Governor State
			1633	Cruise control Pause Switch

Message	Source address	Update Rate	SPN	Signal Names
LFE1 (PGN 65266)	0x00	100ms	183	Engine Fuel Rate
			184	Engine Instantaneous Fuel Economy
			185	Engine Average Fuel Economy
VP1 (PGN 65267)	0xEE	100ms	584	Latitude
			585	Longitude
TIRE1 (PGN 65268)	0x33	100ms	241	Tire Pressure
			242	Tire Temperature
			929	Tire Location
			1697	Tire Sensor Electrical Fault
			1698	Tire Status
			1699	Tire Sensor Enable Status
			2586	Tire Air Leakage Rate
			2587	Tire Pressure Threshold Detection
AMB (PGN 65269)	0x00	100 ms	108	Barometric Pressure
			170	Cab Interior Temperature
			171	Ambient Air Temperature
			172	Engine Intake 1 Air Temperature
IC1 (PGN 65270)	0x00	100 ms	106	Engine Intake Air Pressure
			173	Engine Exhaust Temperature
VEP1 (PGN 65271)	0x17	100 ms	158	Key Switch Battery Potential
			168	Batter Potential / power Input 1
TRF1 (PGN 65272)	0x03	100 ms	124	Transmission Oil Level 1
			177	Transmission 1 Oil Temperature 1
B1 (PGN 65274)	0x17	100 ms	3557	Parking Brake Red Warning Signal
DD (PGN 65276)	0x17	100 ms	80	Washer Fluid level
			96	Fluid Level 1
OI (PGN 65279)	0x00	100ms	97	Water In Fuel Indicator 1
			8428	Fuel Supply Estimated Remaining Distance
400 (PGN 1024)	0x00	100ms	2915	XBR Priority
			2920	External Acceleration Demand
FD7C	0x00	100ms	3698	Exhaust System High Temperature Lamp Command
FEC1	0x03 0x3D 0x00	100ms	623	Red Stop Lamp
FECA	0x03 0x3D 0x00	100ms	624	Amber Warning Lamp
		100ms	987	Protect Lamp
		100ms	1213	Malfunction Indicator Lamp

Message	Source address	Update Rate	SPN	Signal Names
		100ms	1214	Suspect Parameter Number
		100ms	1215	Failure Mode Identifier
		100ms	1706	SPN Conversion Method
		100ms	3038	Flash Malfunction Indicator Lamp
		100ms	3039	Flash Red Stop Lamp (RSL)
		100ms	3040	Flash Amber Warning Lamp (AWL)
	0x03	100ms	3041	Flash Protect Lamp
FEFF(PGN 65265)	0X11	100ms	600	Cruise Control Coast (Decelerate) Switch

Note: Although the SCIM sends output messages, the source address is set as the ECU originating the information.

Note: Messages that rates “on request” are requested by the J1939 request PGN 59904 described in J1939-1. For example, requesting engine hours is done by sending EAFF or EA00 with data E5 FE 00 (hex values).

Note: Not all messages are supported on all vehicles.

Source Addresses and Unit Acronyms

Control Unit	ECU	Source address (SA) or Destination Address (DA) in Hex
Engine Control Module	ECM	0x00
Transmission Control Module	TCM	0x03
Electronically controlled Brake System	EBS	0x0B
Vehicle Master Control Unit	VMCU	0x11
Instrument Cluster	IC	0x17
Driver Assistance Control Unit	DACU	0x2A, 0xE8
Rear Chassis Input Output Module	RCIOM	0x2F
Aftertreatment Control Module	ACM	0x3D
Security & Cab Interface Module	SCIM	0x31, 0x37
Wireless Sensor GateWay	WSGW	0x33
Telematics GateWay	TGW	0xEE

SAE J1939 Control Data Link (Backbone 1)

The systems **control signals** are sent through this link.

The J1939 link is very fast, operating at 500 kbit/s. This operating speed allows the system to function more effectively and adapt quickly to changing conditions and vehicle requirements.



CAUTION

No modifications or connections should be made to wires Backbone 1 (red) or Backbone 2 (black). These wires carry the high-speed communications between the electronic systems in the vehicle. **Any modification, connection to, or damage to these wires can result in the failure of the vehicle electronic systems.**

Terminating Resistor

The Volvo truck have terminating resistors are integrated in the ECU's

The purpose of these resistors is to prevent data link signal reflections.

Notes

SAE J2284 Diagnostic Data Link

This is a dedicated diagnostic data link for powertrain control modules with a signal transfer speed of 500 kbit/s. Also, backbone 2 (J2284) is used by the service tool to reprogram the VMCU, TGW and other control units.



CAUTION

If a circuit must be added to the electrical system, and will carry high currents or frequencies, route it in a location AWAY from wires to prevent mutual inductance from interfering with data link functions.



CAUTION

Wires MUST NOT be cut or spliced for any connections. These wires are used for the transmission of data for diagnostic messages and gauges. Modifying this circuit can cause these functions to fail.

ISO 14229 Data Link

Note: ISO 14229 only applies to vehicles with VOLVO engines.

ISO 14229 is the Powertrain control link. The ISO is used for programming between the ECM, ACM and TCM. It is used primarily to transmit control signals that are shared between other standalone modules. The information on the ISO 14229 control link is used for control functions. Fault messages or diagnostic information also transmits across this link. These control signals may be for engine, transmission and aftertreatment ECUs.

The ISO 14229 operates at 500,000 (500K Baud rate) bits per second. This higher speed allows the system to operate at a faster sampling rate and higher resolution, thus being more capable of improving programming and diagnostic time.

The ISO 14229 data link consists of a pair of 18 gauge un-shielded twisted wires. The designations of the networks are CAN_H and CAN_L. The designations of the individual wires are DL2H and DL2L which are both white with orange stripes. The nominal rate of twist required is 40 twists per meter (3.28 feet). This twist helps protect against electrical interference.

The ISO 14229 data link is electrically terminated at each end with a load resistor, which is commonly referred to as a termination resistor. Each ISO 14229 network has two termination resistors associated with it. Only two termination resistors are allowed within a network. The termination resistor can be located externally as part of the wiring harness, or integrated internally in the ECU/ECM. Any ECU/ECM that does not contain the termination resistor is referred to as a Type I, and an ECU/ECM that contains the termination resistor is referred to as a TYPE II. The correct number of termination resistors can be easily checked by measuring the resistance across cavities 3 and 11 for the 16 pin diagnostic connector. The correct resistance is 50 – 70 ohms. The terminating resistors should each have a resistance of 110 – 130 ohms when tested individually.

Note: It is important to remember the control units in the vehicle and the fault codes in each control unit.

Notes

Diagnostic Connector

The diagnostic connector is located in the driver's side kick panel. The diagnostic connector is connected to the ISO information link and gives the system a way to communicate with an external PC or diagnostic tool.

With a PC or diagnostic tool connected, error codes can be read from all the control units. This is important in fault tracing to carry out basic checks of all the vital parts of the vehicle's electronics.

Some programming can also be done through the diagnostic connector.

Note: For vehicles built after November 17, 2025, the OBD connector has the option to relay FMSnet messages via SCIM.

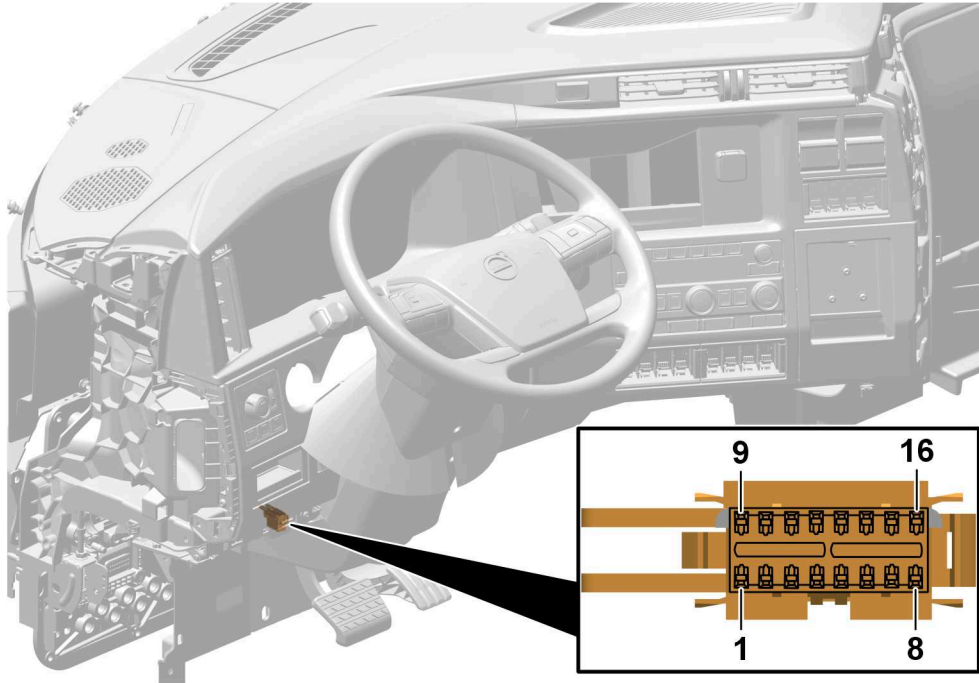

T3203329

1 Diagnostic Connector (16 Pin)

Notes

16 Pin Diagnostic Connector (OBD) pin definition

16 Pin Diagnostic Connector (OBD)	
PIN	Definition
1	OEM discretionary (assigned as: Key switch – ignition signal for AM tool)
2	CAN_H line of SAE J1939 (FMSnet Datalink)
3	OEM discretionary (Not assigned)
4	Chassis ground
5	Signal ground 6 CAN_H line of ISO
6	CAN_H line of ISO 15765-4
7	K line of ISO 9141-2 and ISO 14230-4 (Not Used)
8	OEM discretionary (Not assigned)
9	OEM discretionary (Not assigned)
10	CAN_L line of SAE J1939 (FMSnet Datalink)
11	OEM discretionary (Not assigned)
12	–
13	–
14	CAN_L line of ISO 15765-4
15	J2284 ISO Diagnostics
16	Battery positive voltage

Notes

ECU Functions and Parameter Programming

This section lists functions which will be of interest to Body Builders and others needing to modify certain (programmable) aspects of the ECUs. If an ECU is not included in this section, it is because there are no adjustable functions which can be modified in the field.

Not all functions or parameters listed in this document may apply to the vehicle you have, because of running changes and improvements made over time. Using each component's Main Software part number, the Premium Tech Tool 2 knows which parameters apply, and show only those which are adjustable for that particular vehicle.

Whenever working on the electrical system of the vehicle, certain ECUs such as the Airbag (SRS) ECU, need special handling to avoid damage. Refer to the appropriate ECU sections, and to the individual ECU service manual, for the appropriate precautions.

All ECUs use some form of Input and Output devices to perform their functions. These devices may include switches, sensors, solenoids, and relays. DO NOT tie or splice into an existing sensor or input device used by an ECU, or else proper operation of that sensor may be affected. Likewise, DO NOT tie into an Output device which is controlled by an ECU unless specifically authorized to do so in this document.

Always observe proper Electrostatic Discharge (ESD) precautions while working around the ECUs, as outlined in the "Service Procedures" portion of this document.

The Inputs and Outputs (I/O) of the ECUs follow a certain "logic" which are important to understand when interfacing to the ECUs. The following information explains the terminology used in this document:

Input/Output Type	Definition
Active High (or Active +V)	<p>This input is typically configured with a switch wired to + Voltage. The input has two states; either floating (switch open), or +V (switch closed). The input is considered active when +V is applied.</p> <div data-bbox="662 1058 1239 1297" data-label="Diagram"> </div> <p style="text-align: right; font-size: small;">W9000629</p>
Active Low (or Active ground)	<p>This input is typically configured with a switch wired to ground. The input has two states; either floating (switch open), or grounded (switch closed). The input is considered active when grounded.</p> <div data-bbox="662 1520 1239 1759" data-label="Diagram"> </div> <p style="text-align: right; font-size: small;">W9000630</p>

<p>NC switch to +V</p>	<p>This input type typically has a Normally Closed (NC) switch contact connected to +V. The input becomes active when the switch is opened or the circuit is otherwise broken.</p> <div data-bbox="737 178 1313 422" data-label="Diagram"> </div> <p style="text-align: right;">W9000631</p>
------------------------	--

<p>NC switch to ground</p>	<p>This input type typically has a Normally Closed (NC) switch contact connected to the ground. The input becomes active when the switch is opened or the circuit is otherwise broken.</p> <div data-bbox="737 606 1313 850" data-label="Diagram"> </div> <p style="text-align: right;">W9000632</p>
----------------------------	--

I/O Type	Definition
OUTPUTS	
<p>Active High</p>	<p>This output sources current (the voltage goes high) when active. The other side of the load or controlled device is connected to ground.</p> <div data-bbox="737 1144 1313 1388" data-label="Diagram"> </div> <p style="text-align: right;">W9000633</p>
<p>Active Low</p>	<p>This output sinks current (the voltage goes low, usually to the ground) when active. The other side of the load controlled device must be connected to +V.</p> <div data-bbox="737 1564 1313 1808" data-label="Diagram"> </div> <p style="text-align: right;">W9000634</p>

Many of the functions on today's vehicles are shared among different ECUs. Use the following guide to help decide which ECU controls which functions:

Feature/Function	With Volvo engine, adjust in:
Cruise Control Parameters	VMCU
Idle Shutdown Operation	VMCU
Low Idle Speed Adjustment	VMCU
PTO Programming	SCIM, CCIOM, VMCU and BBM
Road Speed Limits	BBM
All Other Body Builder Related Functions (e.g., switchable engine speed & torque limits, remote throttle activation, etc.)	BBM

Notes

Vehicle Master Control Unit (VMCU)

There are many programmable features of the VMCU; the functions listed here are included because they will be of particular interest to body builders and others needing to modify certain aspects of the VMCU. For a complete list of all programmable parameters, see the appropriate Premium Tech Tool 2 parameter and reprogramming information.

Engine Speed Control

The ESC helps you to maintain engine speed, regardless of engine load. Think of it as cruise control for the engine - only instead of maintaining a steady vehicle speed, it is maintaining engine speed. It is most often used to provide increased steady engine speed when operating auxiliary equipment such as hydraulic pumps or compressors. The term "PTO" has come to mean both the function of maintaining constant engine speed during use of auxiliary equipment, as well as a term for the auxiliary equipment itself.

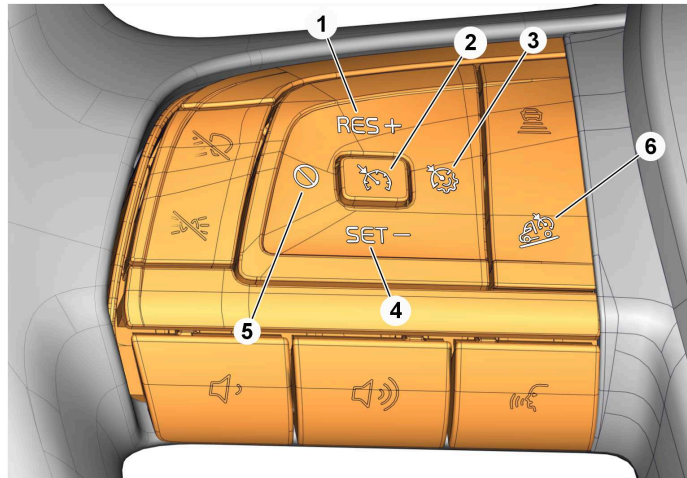

T3202462

- 1 Increase set speed/Resume Cruise
- 2 Cruise Control Enable
- 3 Cruise Over/Under Speed Setting
- 4 Decrease Set Speed/Resume Cruise
- 5 Cancel Cruise
- 6 Downhill Cruise Set

Pin/Connector Information

This function uses the Cruise Control switches. See the VMCU I/O table (**"VMCU Connectors"**, page 113) for pin locations of the Cruise Control On/Off, Resume and Res + / Set - button inputs.

Using the engine speed control at low speeds

Note: To set the factory settings, the PTO must be in neutral and the parking brake must be applied. Refer to the parameter table below.

To enable the engine speed control at low speed, follow the steps below:

- Press the Cruise Control Enable button (2).
- Drive and maintain the engine speed at 1000 rpm.
- Press the SET button (4).
- Release the accelerator pedal.

The engine speed control can be used at very low speeds, for example, at speeds below 2 mph when laying asphalt.

The engine speed can be reduced to 600 rpm and the truck will still roll steadily.

The lowest speed depends on the truck's powertrain. A truck with crawler gear can maintain a speed of 0.5-2 mph at 600 rpm.

Using the constant engine speed

- Press the Cruise Control Enable button (2). A menu opens in the instrument display.
- Select Engine control in the menu.
- Press the SET/- button (4) or Cruise Control Enable button (2) or wait a moment for engine control to be selected.
- Once the engine speed control is activated, the ECM sends a signal to the VMCU.
- If you want to raise or lower the engine speed, press the RES/+ button (1) or SET/- button (4).
- To increase the engine speed to a pre-programmed value (normally 1000 rpm), press the RES/+ button (1).
- To resume to the original engine speed, press the Cancel Cruise button (5).
- To deactivate constant engine speed, press and hold the Cancel Cruise button (5).

Note: During a regeneration of the diesel particulate filter, the idling speed will be slightly increased without the possibility of changing it.

Parameter code	Description	Min	Default value	Max	Unit
P1F7M	Specifies maximum engine speed available via cruise control buttons or digital inputs to the BBM.	600	2100	2550	r/min
P1F7N	Specifies the minimum engine speed, which can be achieved when engine speed control (set via the cruise control buttons) is active. This will also be the minimum speed when using the cruise control - (minus) button or the digital decrease engine speed input to the BBM.	0	600	2550	r/min
P1IZF	Engine speed step up size when increasing engine speed with cruise control + (plus) button or digital increase engine speed input to the BBM. Step size is 10 r/min.	0	50	250	r/min/step
P1IZG	Engine speed step down size when decreasing engine speed with cruise control - (minus) button or digital decrease engine speed input to the BBM. Step size is 10 r/min.	0	50	250	r/min/step
P1BUQ	Time threshold before the engine speed (set by pressing cruise control Res+/Set- buttons) changes by ramping instead of stepping.	0	0.5	12.75	s
P1BTQ	Engine speed trim factor for engine speed ramp up when using cruise control buttons or digital increase engine speed input to BBM.	0	100	1000	rpm/s
P1BTP	Engine speed trim factor for engine speed ramp down when using cruise control buttons or digital decrease engine speed input to BBM.	0	100	1000	rpm/s
P1BTO	Toggling function for engine speed resume switch.	-	False	-	False/True
P1B0V	Specifies which vehicle speed limit, Engine Speed Control (ESC) can be used from the speed control steering wheel buttons.	0	0	30	km/h

Parameters for basic engine speed control using steering wheel cruise control buttons

Parameter code	Description	Min	Default value	Max
P1ISH [0]	Engine speed mode 0 — Resume speed (Unit: Rpm)	0	1000	2550
P1BT6 [0]	Engine speed mode 0 — Entry condition, brake 0 = Condition disabled 1 = Parking brake applied 2 = Service brake applied 3 = Parking brake applied or service brake applied	0	1	3
P1BT9 [0]	Engine speed mode 0 — Entry condition, neutral gear 0 = Condition not used 1 = Gearbox in neutral 2 = Gearbox not in neutral	0	1	2
P1BUD [0]	Engine speed mode 0 — Exit condition, neutral gear 0 = Condition disabled 1 = Gearbox not in neutral 2 = Gearbox in neutral	0	1	2
P1BT8 [0]	Engine speed mode 0 — Entry condition, vehicle speed below set value. Note that engine speed control from the steering wheel buttons will be shut off at 0 km/h (default setting, parameter code P1B0V). (Unit: km/h)	0	16	255
P1BUC [0]	Engine speed mode 0 — Deactivation above set value. Note that engine speed control from the steering wheel buttons will be shut off at 0 km/h (default setting, parameter code P1B0V). (Unit: km/h)	0	16	255

Parameters for PTO1

Parameter code	Description	Min	Default value	Max
P1ISH [1]	Engine speed mode 1 — Resume speed (Unit: Rpm)	0	800	2550
P1BT6 [1]	Engine speed mode 1 — Entry condition, brake 0 = Condition disabled 1 = Parking brake applied 2 = Service brake applied 3 = Parking brake applied or service brake applied	0	1	3
P1BT9 [1]	Engine speed mode 1 — Entry condition, neutral gear 0 = Condition disabled 1 = Gearbox in neutral 2 = Gearbox not in neutral	0	0	2
P1BUD [1]	Engine speed mode 1 — Exit condition, neutral gear 0 = Condition disabled 1 = Gearbox not in neutral 2 = Gearbox in neutral	0	0	2
P1BT8 [1]	Engine speed mode 1 — Entry condition, vehicle speed below set value. (Unit: km/h)	0	16	255
P1BUC [1]	Engine speed mode 1 — Deactivation above set value (Unit: km/h)	0	16	255

Parameters for PTO2

Parameter code	Description	Min	Default value	Max
P1ISH [2]	Engine speed mode 2 — Resume speed (Unit: Rpm)	0	1000	2550
P1BT6 [2]	Engine speed mode 2 — Entry condition, brake 0 = Condition disabled 1 = Parking brake applied 2 = Service brake applied 3 = Parking brake applied or service brake applied	0	1	3
P1BT9 [2]	Engine speed mode 2 — Entry condition, neutral gear 0 = Condition disabled 1 = Gearbox in neutral 2 = Gearbox not in neutral	0	0	2
P1BUD [2]	Engine speed mode 2 — Exit condition, neutral gear 0 = Condition disabled 1 = Gearbox not in neutral 2 = Gearbox in neutral	0	0	2
P1BT8 [2]	Engine speed mode 2 — Entry condition, vehicle speed below set value (Unit: km/h)	0	16	255
P1BUC [2]	Engine speed mode 2 — Deactivation above set value (Unit: km/h)	0	16	255

Notes

BBM

Engine Start/Shutdown Inputs

This function is applicable only if the AESS3 variant is selected, auto start and stop connector is pre installed from the factory. Two inputs are provided to allow remote engine Start and Stop function.

Connector housing - #993363

Terminal - #983014

Cable seal - #983015

Mating Connector housing- #993360

Terminal - #983014

Cable seal - #983015

Pin Name	I/O, Type	BBM Pin No.	Comment
Engine Start request		B1:16	
Engine Shutdown request		B1:17	

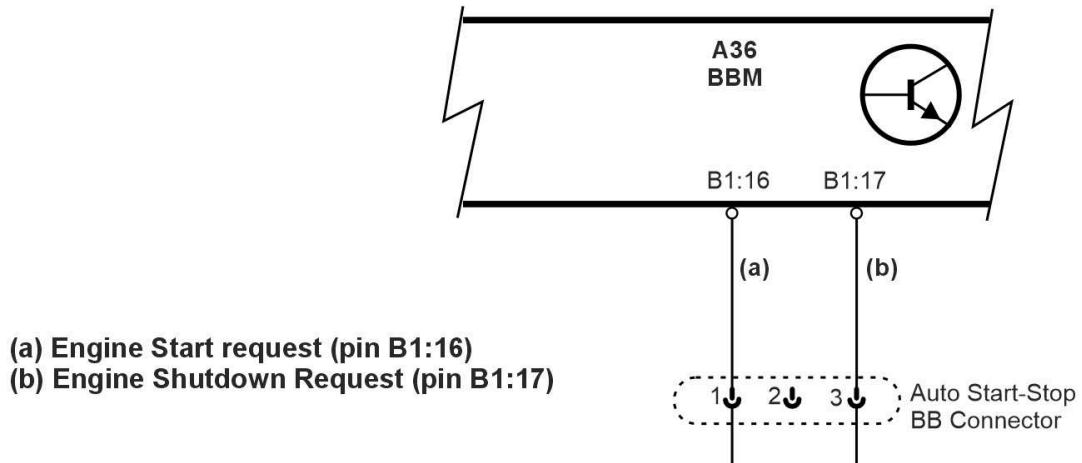

T3204865

Pre-requisites/Conditions for Activation

For Remote Engine Start:

- 1 Transmission is in Neutral — P1EK6[2].
- 2 Parking brake is applied — P1EK6[1].
- 3 No remote stop is requested.
- 4 No remote start inhibition is requested.
- 5 Engine is not running.
- 6 Bonnet is not open — P12RX.
- 7 No remote start inhibition is requested through the cab switch.
- 8 B1:16 is active.

For Remote Engine Stop:

- 1 Transmission is in Neutral — P1EK5[2].
- 2 Parking brake is applied — P1EK5[1].
- 3 Engine stop is allowed from remote full brakes - applicable if P1GBS is set to 1.
- 4 B1:17 is active.

Parameters Engine start

Parameter code	Description	Min	Default value	Max
P1BVN	Remote engine start function, enable True/False.		False	
P1EK6 [0]	Remote engine start control, enable 0 - function disabled 1 - function enabled	0	1	1
P1EK6 [1]	Remote Inhibit Start Enabled: 0 - function disabled 1 - function enabled	0	1	1
P1EK6 [2]	Remote Start Transmission Condition: 0 - No transmission position condition 1 - Transmission in Neutral position	0	1	1
P1EK6 [3]	Remote Start Park Brake Condition 0 -No park brake condition 1 - Park brake shall be activated	0	1	1
P1BVQ	Engine Start Remote Inhibit , Function TRUE = Enabled FALSE = Disabled		True	
P12RX	Enables the inhibition of the remote engine start depending on the hood state. TRUE = Remote Engine Start inhibited when the hood is open FALSE = Remote Engine Start not inhibited when the hood is open		False	
P1B1H	If remote start stop inhibit control commands is enabled. 0 = Remote engine start, stop or inhibit digital input commands enabled 1 = Remote engine start, stop or inhibit BB network commands enabled 2 = Remote engine start, stop or inhibit both digital input & BB network commands are enabled	0	0	2

Parameters Engine shutdown

Parameter code	Description	Min	Default value	Max	Unit
P1EK5 [0]	Engine remote shutdown, enable True/False		False		
P1EK5 [1]	Engine shut down condition, parking brake applied 0 = No parking brake condition 1 = Parking brake activated	0	1	1	0 = No park brake condition 1 = Park brake activated
P1EK5 [2]	Engine shut down condition, vehicle road speed not above set value (Unit: km/h)	0	10	250	0–250 km/h
P1BVM	Engine remote shutdown, enable True/False		False		

Engine speed control through BodylinkIV

The Engine speed control resume can be done via Cruise control button "CC ON/OFF" from the SWS.

"RES + "Switch in the SWS panel is used to Increase the engine speed, the PTO set speed can be controlled via this switch.

"SET - "Switch in the SWS panel is used to decrease the engine speed, the PTO set speed can be controlled via this switch.

Once a pre-set PTO speed input is enabled, per the PTO engine speed control setting and the user can increase the engine speed using the PTO engine speed Increase input .

This input will force the engine speed to return to the original selected PTO pre-set speed.

The adjusted PTO Engine Speed will be retained in memory until the ignition is turned off, or until the PTO Engine Speed Control mode changes.

With Volvo Engine (programmable functions handled in VMCU):

Pressing the "Res+" button will take the engine to the preset speed programmed in VMCU parameter (P1F7N). Engine speed may be adjusted up or down from the default speed by either 'tapping' (for step-changes) or 'holding' (for ramp-changes) the "Res+" or "Set-" buttons. The RPM change for step changes is programmable in the VMCU, the ramp change rate is by default programmed for 50 RPM per second. When adjusting the speed using this method, Min. and Max. engine speed limits programmed into the VMCU will be enforced. This mode may also be entered by using the Accelerator Pedal to obtain the desired engine speed, then pressing "Res+" or "Set-", which will then maintain the current engine speed.

Other Information/Notes

The P1IZF and P1IZG parameter only affects the "step" adjust function when the CC Res (+) or Set (-) buttons are 'tapped'. If the buttons are "held", a default ramp rate of 100 RPM per second will be used, the P1BTQ and P1BTP parameters can be modified to increase or decrease the ramp rate.

Notes

Pin/Connector Information

Pin Name	I/O, Type	BBM Pin No.	Bodylink Pin No.
Engine speed control ON/OFF	12 V	B1:4	20
Engine Speed Control Re- sume/Increase	12 V	B1:5	24
Engine Speed Control Set/ Decrease	12 V	B1:6	23

- (a) Engine speed control ON/OFF (B1:4)
 (b) Engine speed control Resume/increase (B1:5)
 (c) Engine speed control set/decrease (B1:6)

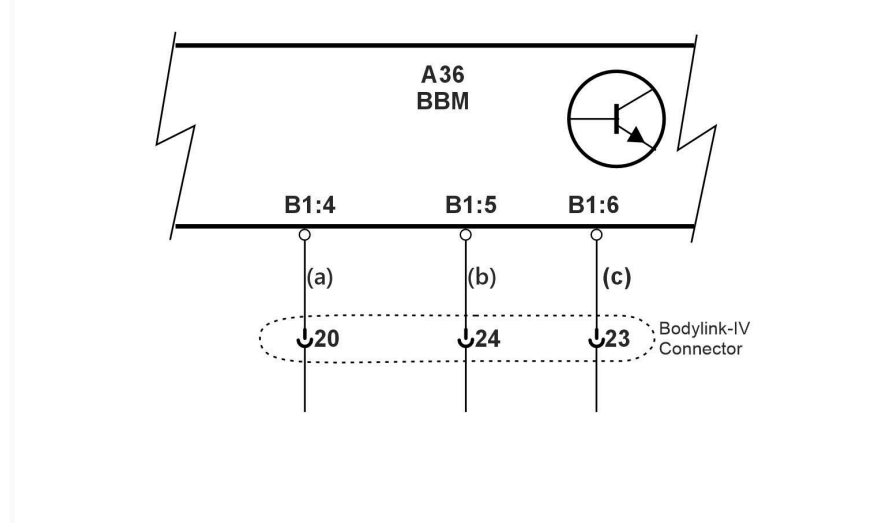

T3217669

Pre-requisites/Conditions for Activation

- Function must be enabled in the BBM
- PTO pre-set speed resume input pin must be active
- PTO pre-set engine speed input must be active.

Engine Speed Control Mode

The Engine Speed Control Mode function is a programmable feature that allows the body builder to preset an engine speed for the Power Take-Off (PTO). This function can be used through hardwired switches connected to the BBM through the Bodylink IV connector, as shown below.

The PTO engine speed will be configured through parameter “P1TZY ”

This input has priority over any active ESC modes, and any driver-demand inputs such as the accelerator pedal.

Pin/Connector Information

Pin Name	I/O, Type	BBM Pin No.	Bodylink Pin No.
Engine speed control	12 V	B1:3	20

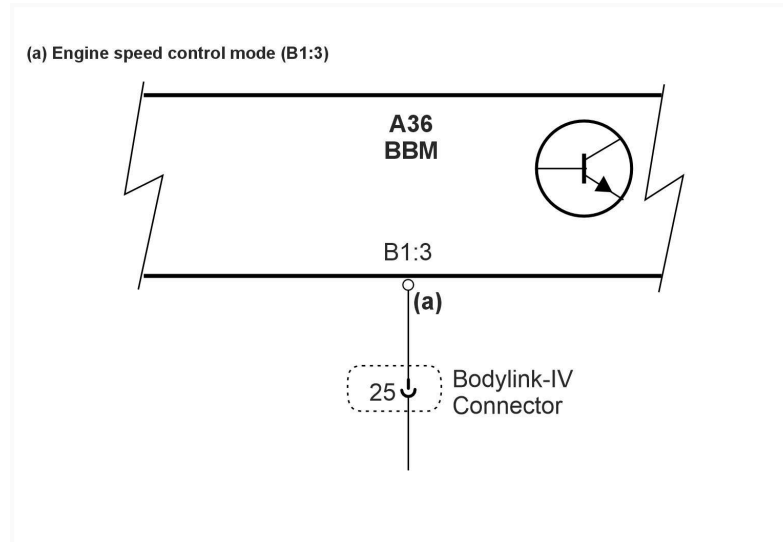

T3215335

Pre-requisites/Conditions for Activation

- Function must be enabled in the BBM.
- The ESC mode input pin must be active.
- The engine speed must be > 0 , and no engine speed related fault codes present.
- Any programmed conditions, as determined by parameter settings for the corresponding PTO ModeX, must be satisfied (e.g, Park brake, PTO dash switch, etc.).
- The parameter P1ISH must be enabled.

Parameters Engine Speed control

Parameter code	Description	Min	Default value	Max	Unit
P1ISH [1]	Engine Speed Control	0	800	2550	RPM

Pre-requisites/Conditions for Activation of ESC mode 1

- One of the P1TZY parameters must be enabled.
- The corresponding P1TZY input must be activated.
- The engine speed must be > 0, and no engine speed related fault codes present.
- Any programmed conditions, as determined by parameter settings for the corresponding PTO ModeX, must be met (e.g., park brake, PTO dash switch, etc.).
- When the P1TZY input activates for the first time in each ignition cycle, the BBM must detect the input going OFF and then ON before it engages the corresponding PTO Engine Speed Control. This prevents a switch that was accidentally left ON from automatically engaging the PTO.

Notes

PTO Operation

"PTO" is a mode which uses the Cruise Control switches or hardwired switch to control the engine speed at a pre set level. It can be used for PTO engine speed control, to maintain engine speed at an elevated idle speed for hydraulic pumps or body equipment. It can also control a physical output for engaging hydraulic equipment via air or fluid solenoids.

Pre-requisites/PTO Activation when the vehicle is parked

To activate PTO when the vehicle is parked:

- Start the engine.
- Place the gear selector (stalk switch) in neutral position.
- Switch On the PTO switch on the dashboard
- Ensure that the PTO tell-tale indication appears in the instrument display.

Note: The neutral gear N1 or N2 can be selected based on the parameter shown below.

Pre-requisites/PTO Activation when the vehicle is moving/running slowly

Note: Factory settings require PTO in neutral and the parking brake set. Parameters shown below would need to be changed.

To activate PTO when the vehicle is moving/running slowly :

- The gear selector (stalk switch) is in manual (M) or automatic (A) or reverse (R) drive position.
- The gearbox is in any low range gear up to 6th gear or reverse gear R1 or R2.
- The vehicle speed is less than 6.2 mph (10 km/hr).
- Switch On the PTO switch on the dashboard.
- Ensure that the PTO tell-tale indication appears in the instrument display.

Note: When the vehicle is in standstill, select any low range gear, from 1 to 6, or reverse gear (R1 or R2) before activating the PTO. Once the PTO is engaged, the gear position (start gear) cannot be changed. When the PTO is active and if you need to change the gear position, turn Off the PTO and then change the gear position. Use the gear selector (stalk switch) to upshift or downshift the gear.

Note: For further PTO related parameter Information, please refer the Section-9 of Volvo Body Builder instructions.

Parameters for Neutral Gear selection

Parameter code	Description	Min	Default value	Max
P1A05	Split Gear for Transmission PTO1. 0 = Split selected by driver 1 = Use low split 2 = Use high split	0	1	2
P1A06	Split Gear for Transmission PTO2 0 = Split selected by driver 1 = Use low split 2 = Use high split	0	1	2

Remote PTO activation

Once the BBMs Engine Speed Control function is active, the set-speed may be adjusted up/down by use of either the Remote PTO Speed INC/DEC inputs via hardwired switches and configuring the parameters mentioned (**Refer to “Engine Speed Control”, page 53**).

Pin/Connector Information

Pin Name	I/O, Type	BBM Pin No.	Bodylink Pin No.
PTO Active Output	Output, Active High	B3:7	26
PTO 1 Request Input	Input, Active High	B1:1	19
PTO 2 Request Input	Input, Active High	B1:2	18

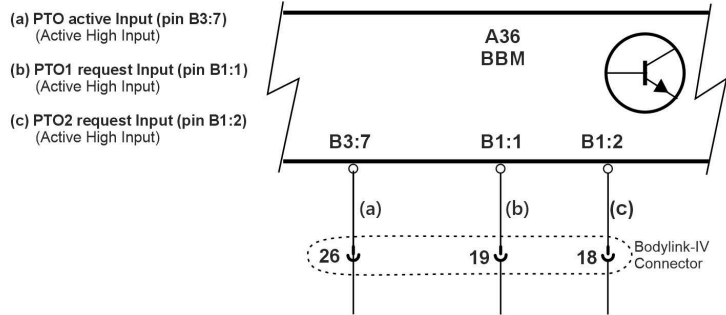

T3204869

Notes

Body Builder Module

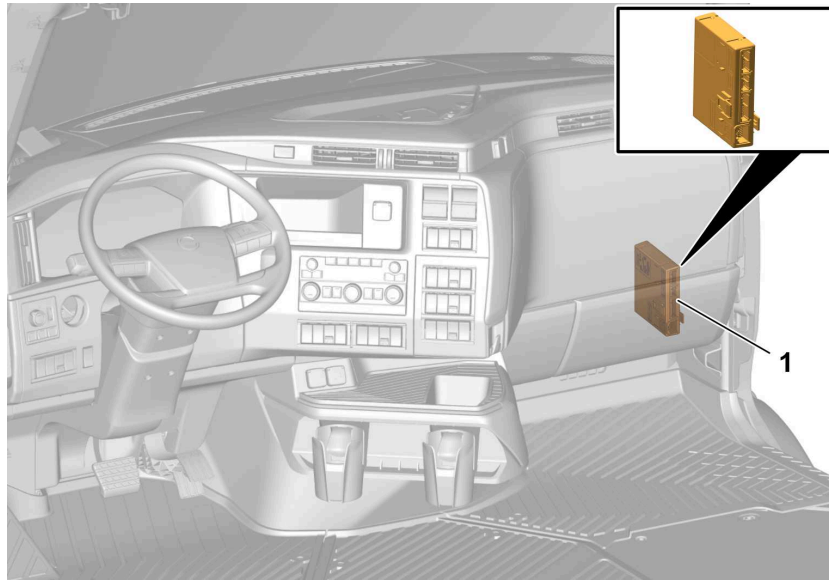

T3201031

1. Body builder module

The BBM is the main interface for all body builder functionality that needs to be controlled from the chassis, such as PTO (Power Take-Off), engine speed control and remote engine start and stop.

The BBM provides various inputs and outputs, including digital inputs, analog inputs, PWM (Pulse Width Modulated) inputs and outputs, and relay drivers.

The BBM is on the dashboard and has a power supply and output of 24 V.

The BBM is powered by the FRC (Fuse and Relay Center) and I/O can be accessed via BBEC (Body Builder Electrical Center).

Hardwired functions

- PTO and engine speed control
- Remote engine start and stop
- RSL (Road Speed Limiter)

Summary of adjustable BBM Parameters

The following pages contain lists of the Customer-changeable parameter settings for the BBM. For each ECU, there are two lists:

- "Vehicle" parameters; these are field-changeable using Tech Tool with a network connection. The network connection is so a central record of the changes can be maintained by Volvo Trucks North America.
- "Customer" parameters; these are field-changeable using Tech Tool without a network connection.

For each parameter, the following information is supplied:

Parameter code

Description of parameter - for parameters which are fully described elsewhere in this document, the only description given here will be a reference to the appropriate section elsewhere.

Default Value

Minimum value and maximum value

BBM Connectors

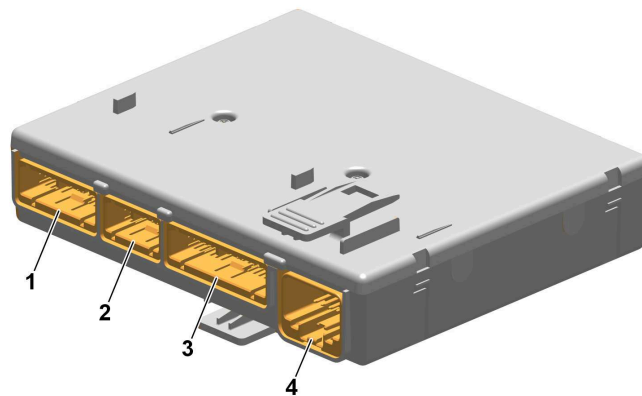

T3204407

- 1 B3
- 2 B2
- 3 B1
- 4 A

Note: The presence of a pin description in the following tables does not guarantee that the corresponding wiring or circuit is installed in the vehicle. Wiring may not be present for all listed pins, as installation depends on the specific vehicle configuration and options ordered.

BBM Connector 1 (B3)

Pin	Default functions	I/O
B3:1	PTO3/Splitbox PTO Solenoid valve	DOH 2
B3:2	Vehicle warning	DOH 4
B3:3	AuxDO5 (w/ Switch Not Assigned)	DOH 1
B3:4	AuxDO3 (w/ Switch Not Assigned)	DOH 3
B3:5	AuxDO4 (w/ Switch Not Assigned)	DOH 14
B3:6	AuxDO6 (w/ Switch Not Assigned)	DOH 10
B3:7	Programmable Logics Output 11 (Engine Speed > 1000 r/min)	DOH 12
B3:8	Direction indicator, front right	DOH 9
B3:9	Programmable Logics Output 12 (Any PTO Active)	DOH 11
B3:10	PTO4 valve	DOH 6
B3:11	Analog equipment value 2 to display	A13
B3:12	Analog engine speed control input	A12
B3:13	Analog equipment value 1 to display	A11
B3:14	Analog sensors supply (5V)	A01
B3:15	Analog sensors ground	A GND
B3:16	Switch supply, 24V, current limited to 300 mA	SFI
B3:17	Programmable Logics Output 13 (Neutral)	DOH 13
B3:18	Corrected vehicle speed (Tachograph B7 similar)	PWM 2
B3:19	Vehicle distance 4 pulses/meter (Tachograph B8)	PWM 1
B3:20	Direction indicator, front left	DOH 8
B3:21	Plow light; Dipped beam	DOH 5
B3:22	Plow light; Full beam	DOH 7

BBM Connector 2 (B2)

Pin	Default functions	I/O
B2:1	Autoneutral active	DOL 3
B2:2	Programmable Logic Output 5 (Reverse Gear Engaged)	DOL 1
B2:3	Programmable Logic Output 7 (Park Brake Status)	DOL 4
B2:4	Road speed limit 2	DIH 9
B2:5	Road speed limit 3	DIH 26
B2:6	Inhibit height control	DIH 17
B2:7	Not used	–
B2:8	Not used	–
B2:9	Not used	–
B2:10	Programmable Logic Output 16 (Vehicle Speed > 5km/h)	DOL2
B2:11	Spare	DIH 27
B2:12	Park brake request Immobilization Inhibition Park Brake Release Inhibition Cancel	DIH 18
B2:13	Second gear selector, reverse gear	DIH 8
B2:14	Autoneutral enable	DIH 25

BBM Connector 3 (B1)

Pin	Default functions	I/O
B1:1	PTO1 request	DIH 15
B1:2	PTO2 request	DIH 6
B1:3	Engine speed control selector 1	DIH 23
B1:4	Engine Speed Control Enable	DIH 14
B1:5	Engine speed control Increase / Resume	DIH 5
B1:6	Engine Speed Control Set/Decrease	DIH 22
B1:7	Engine speed control selector 2	DIH 13
B1:8	Not Assigned	DIH 1
B1:9	Display icon, Equipment status 2	DIH 10
B1:10	Display icon, Equipment status 3	DIH 19
B1:11	Display icon, Equipment status 4	DIL 1
B1:12	Display icon, Equipment status 5	DIL 2
B1:13	Full Brakes Request Engine Start Inhibit Remote Immobilization Park Brake release Inhibition	DIL 3
B1:14	Engine torque limit	DIL 4
B1:15	Engine speed limit	DIH 16
B1:16	Engine start request	DIH 7
B1:17	Engine shut down request	DIH 24
B1:18	PWM External Engine speed control	F11
B1:19	Enable second driver interface	DIH 4
B1:20	Kneeling, air suspension	DIH 21
B1:21	Second gear selector, neutral	DIH 12
B1:22	Second gear selector, forward gear	DIH 3
B1:23	Engine Speed Control Cancel	DIH 20
B1:24	Not Assigned	DIH 11
B1:25	PTO3/Splitbox PTO, request	DIH 2
B1:26	PTO3/Splitbox PTO, feedback switch	DIL 5
B1:27	Remote PB Redundancy	DIL 6
B1:28	PWM input, value to display	F12
B1:29	Bodybuilder CAN network, High	CAN 3H
B1:30	Bodybuilder CAN network, Low	CAN 3L

BBM Connector 4 (A)

Pin	Default functions	I/O
1	Backbone 1 CAN net (j1939-15 250kbps)	CAN 1 L
2	Backbone 1 CAN net (j1939-15 250kbps)	CAN 1 H
3	Backbone 2 CAN net (j2284-3 500kbps)	CAN 2 L
4	Backbone 2 CAN net (j2284-3 500kbps)	CAN 2 H
5	Pin reserved for future use	FUT 6
6	Pin reserved for future use	FUT 5
7	BBM power supply (24 V) from FRC	UBAT
8	Pin reserved for future use	FUT 1
9	Pin reserved for future use	FUT 4
10	Pin reserved for future use	FUT 3
11	Pin reserved for future use	FUT 2
12	BBM power ground	GND

FRC (Fuse and relay center)

The FRC contains fuses and relays that provide protected 24V power to the vehicle's electrical system. The FRC receives power from the 12V/24V Chassis Fusebox (FB03) and is grounded to Stud 3, located inside the cab.

The truck's fuses and relays are located under the cover in the center of the instrument panel.



WARNING

Always use fuses with the correct rating when changing. Never overfuse. Never install a fuse higher than the instructed rating.

Note: Set the electrical component in the "OFF" position if possible, before changing the fuse. The fuse holder can be burned, if the voltage remains switched on.

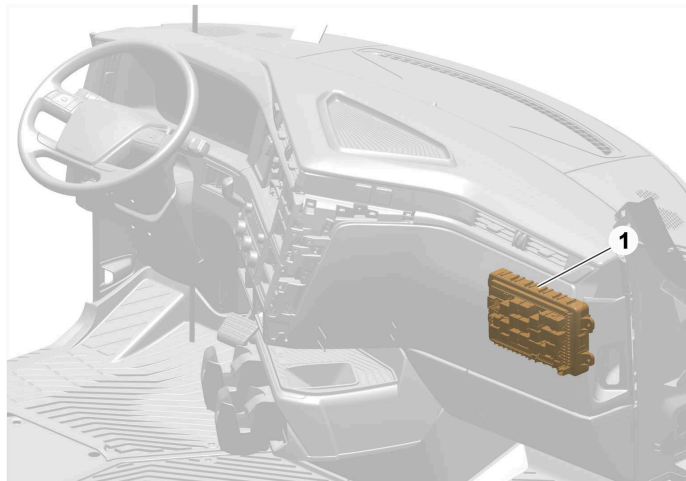

T3211827

1. FRC location

FRC 24V layout details

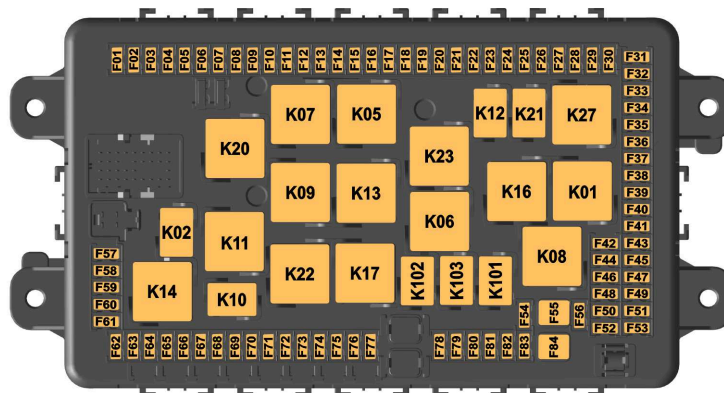

T3211830

Fuses

Fuse Number	Rated Current Ampere (A)	Function	Fuse Number	Rated Current Ampere (A)	Function
F01	30	BBEC (Body Builder Electrical Center) ignition power supply -1	F43	5	DACU (Driver Assistance Control Unit) power supply
F02	5	Spare	F44	3	SID (Secondary Information Display) power supply
F03	10	Spare	F45	5	Spare
F04	10	Vendor transmission PTO (Power Take-Off)	F46	3	Spare
F05	10	Spare	F47	5	Spare
F06	3	Interior lighting	F48	3	Spare
F07	15	Seat heating	F49	5	CoPilot Display power supply
F08	20	Windshield wiper motor	F50	3	Spare
F09	30	BBEC (Body Builder Electrical Center) main power supply -1	F51	3	DECM (Driver-Environment Control Module) power supply
F10	20	VMCU (Vehicle Master Control Unit) power supply -1	F52	3	Telematics system power supply
F11	10	VMCU (Vehicle Master Control Unit) power supply -2	F53	5	PDU (Power Distribution Unit) (ESS (Energy Storage System)) 48V ¹
F12	15	VMCU (Vehicle Master Control Unit) power supply -3	F54	15	Spare
F13	10	Spare	F55	40	Auxiliary BBEC (Body Builder Electrical Center) power supply
F14	15	Cab parking heater power supply	F56	10	Spare
F15	20	BBEC (Body Builder Electrical Center) ignition power supply -2	F57	15	Spare
F16	20	BBEC (Body Builder Electrical Center) main power supply -2	F58	5	Camera power supply
F17	10	BBM (Body Builder Module) power supply	F59	10	Spare
F18	20	Spare	F60	15	Spare for cigarette lighter and reserved for passenger seat fridge
F19	5	Spare	F61	15	Spare

F20	5	SRS (Supplementary Restraint System) power supply	F62	20	Spare
F21	30	Spare	F63	5	Spare
F22	15	Spare	F64	20	Spare
F23	20	Amplifier	F65	3	Spare
F24	10	SCIM (Security and Cab Interface Module) power supply	F66	10	Refrigerator
F25	20	Cab HVAC (Heating, Ventilation and Air Conditioning) power supply	F67	20	Spare
F26	15	Mirror heater power supply-2	F68	5	Interior auxiliary fan power supply
F27	15	Mirror heater power supply-1	F69	5	USB (Universal Serial Bus) plug charger
F28	5	Spare	F70	5	Spare
F29	3	Tachograph ignition power supply	F71	10	Spare
F30	15	IPC (Integrated Parking Cooler) power supply	F72	10	VRU (Vulnerable Road User) side radar sensor
F31	10	Spare	F73	10	Spare
F32	20	Spare Ignition power supply	F74	15	Side reverse work light EL2
F33	20	PDM (Passenger Door Module) power supply	F75	15	Spare
F34	20	DDM (Driver Door Module) power supply	F76	15	Spare
F35	20	Cab body work light EL3	F77	15	Spare
F36	20	Beacon warning lamp power supply	F78	20	Spare
F37	10	Spare	F79	15	Windshield heater
F38	30	Spare	F80	20	CCM (Climate Control Module) power supply
F39	30	Spare	F81	15	BBM (Body Builder Module) power supply
F40	30	Coffee maker	F82	15	Spare
F41	10	Spare	F83	5	LECM (Living Environment Control Module) power supply
F42	10	DMS (Digital Mirror System) power supply	F84	40	Aux BBEC power supply

1 Applicable only for vehicles with the variant IEMC-C24

Relays

Relay number	Relay rating in Ampere [A]	Function
K01	40	Cab body work light EL3 relay
K02	10	Refrigerator relay
K05	20	Windscreen wiper On/Off relay
K06	20	Windscreen wiper Low/High relay
K07	40	BB (Body Builder) main power supply relay
K08	40	Accessories relay
K09	40	Engine running relay power supply
K10	10	Camera relay power supply
K11	40	Cab power supply 4 relay
K12	10	Spare
K13	40	Reverse side working lamp EL2 relay
K14	40	Spare
K16	20	Mirror heating relay
K17	20	Windscreen heater relay
K20	40	BB (Body Builder) ignition power supply relay
K21	10	Spare relay
K22	40	VRU (Vulnerable Road User) side radar sensor ignition power supply relay
K23	40	Spare
K27	40	Beacon warning lamps relay
K101	10	Spare
K102	10	Spare
K103	10	Spare

Notes

12V Fuse holder

The 12V Fuse Holder provides protected power for 12V cab load functions, such as the PDCs, OBD port, and in-cab charging features. It receives power directly from the BMPU.

The 12V Fuse Holder is mounted underneath the Cab FRC.

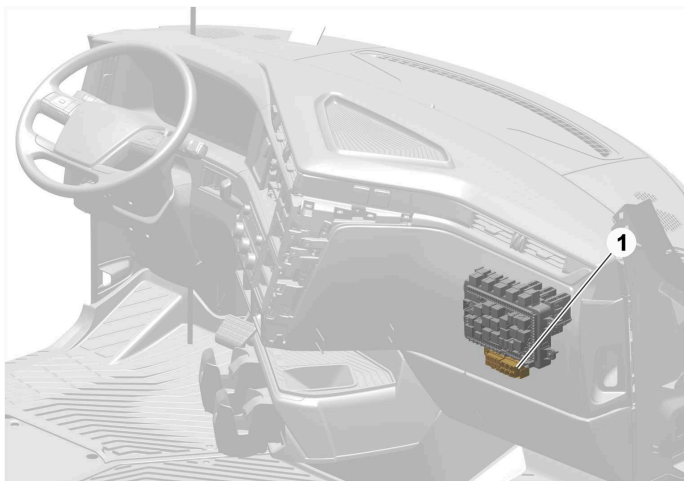

T3211833

1. 12 V fuse holder location

Fuse holder layout details

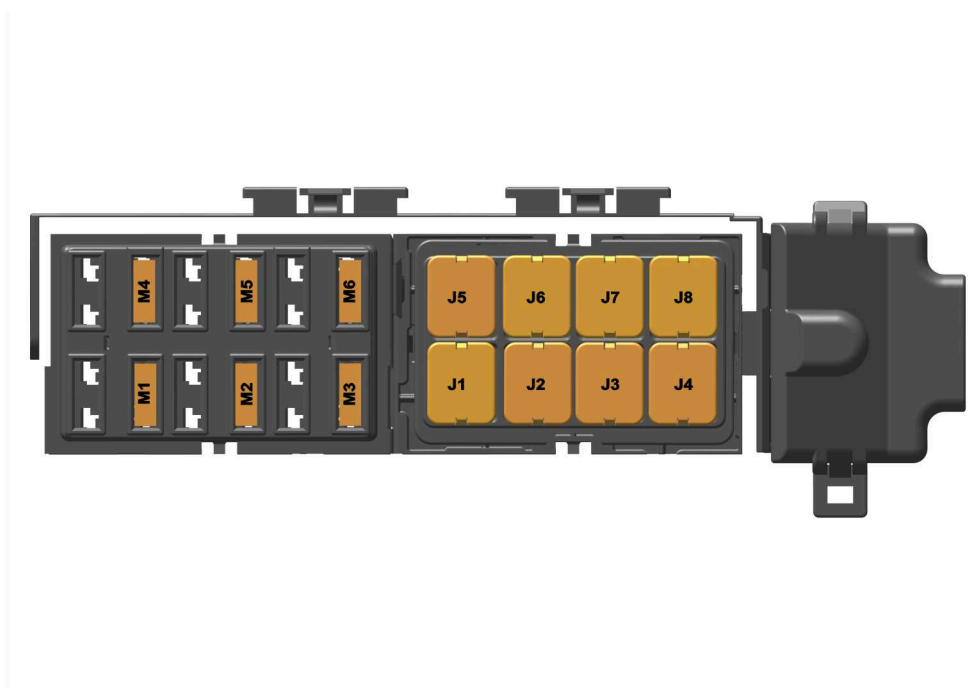

T3211834

Fuses

Fuse Number	Rated Current Ampere (A)	Function
J1	40	Body builder (A) PDC (Power Distribution Controller)
J2	40	Body builder (B) PDC (Power Distribution Controller)
J3	40	Instrument panel PDC (Power Distribution Controller)
J4	40	Cab PDC (Power Distribution Controller)
J5	30	BBM (Body Builder Module)
J6	40	Auxiliary BBEC (Body Builder Electrical Center)
J7	-	Spare
J8	-	Spare
M1	10	Radio
M2	20	Auxiliary BBEC (Body Builder Electrical Center)
M3	20	BBEC (Body Builder Electrical Center)
M4	10	Spare
M5	10	RP1226
M6	10	OBD (On-Board Diagnostics) connector

Notes

EFRC (External Fuse and relay center)

The EFRC contains fuses and relays that provide protected 24V power to components located on the chassis. It receives power from the 12V/24V Chassis Fusebox (FB04).

This fuse panel (EFRC) is located under the hood toward the driver's side of the truck. The fuse and relay locations are etched into the inside cover.



WARNING

Always use fuses with the correct rating when changing. Never overfuse. Never install a fuse higher than the instructed rating.

Note: Set the electrical component in the "OFF" position if possible, before changing the fuse. The fuse holder can be burned, if the voltage remains switched on.

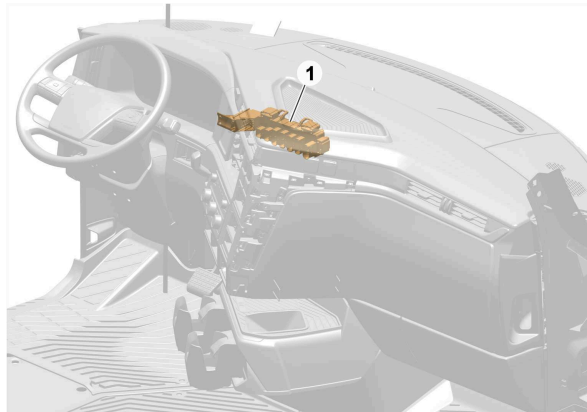

T3211828

1. EFRC location

EFRC 24V layout details

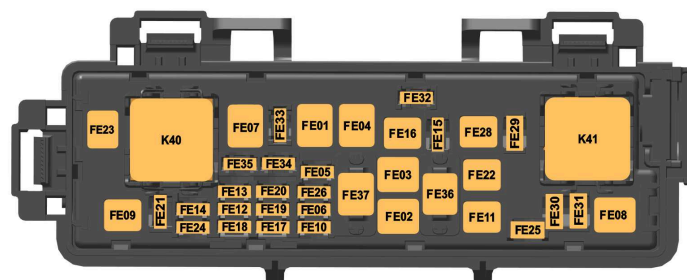

T3211831

Fuses

Fuse Number	Rated Current Ampere (A)	Function
FE01	30	CCIOM (Center Chassis I/O Module) Power supply
FE02	30	FCIOM (Front Chassis I/O Module) power supply
FE03	30	CCIOM (Centre Chassis I/O Module) power supply
FE04	30	RCIOM (Rear Chassis I/O Module) power supply
FE05	20	ACM (Aftertreatment Control Module)
FE06	20	Spare
FE07	50	Integrated Parking Cooler
FE08	30	Spare
FE09	60	Spare
F10	20	Spare
FE11	40	Spare
FE12	15	ECM (Engine Control Module) load -1
FE13	10	ECM (Engine Control Module) load -2
FE14	20	TECU (Transmission Electronic Control Unit)
FE15	30	ECM (Engine Control Module) power
FE16	40	Spare
FE17	10	ECM (Engine Control Module) load -3/ Oil level sensor
FE18	15	ECM (Engine Control Module) load -4
FE19	15	Fuel filter heater
FE20	20	EATS (Exhaust Aftertreatment System) loads
FE21	15	Spare
FE22	40	Spare
FE23	60	Spare
FE24	20	Spare
FE25	20	Spare
FE26	20	Spare
FE28	30	Spare
FE29	20	Spare
FE30	10	Spare
FE31	20	Spare
FE32	–	Spare

FE33	–	Spare
FE34	–	Spare
FE35	–	Spare
FE36	–	Spare
FE37	–	Spare

Relays

Relay number	Relay rating in Ampere [A]	Function
K40	40	ECM (Engine Control Module) power relay
K41	40	Spare

Notes

12V/24V Chassis Fusebox

The 12V/24V Chassis fusebox is designed to provide a combination of 12V and 24V protected power to the vehicle's electrical system. It receives power directly from the batteries and distributes this power to the rest of the truck via the Cab and Chassis FRCs.

The fuse box is mounted on the rear plate of the battery box.

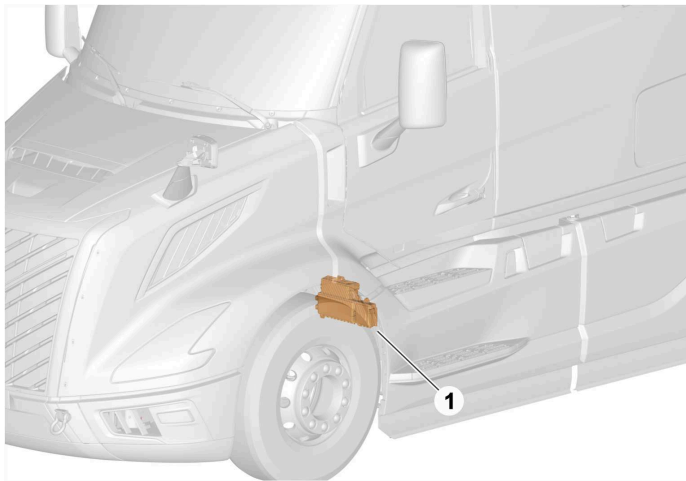

T3211829

1. 12V/24V Chassis fusebox location

CMEC(Chassis-Mounted Electrical Center) Connectors details

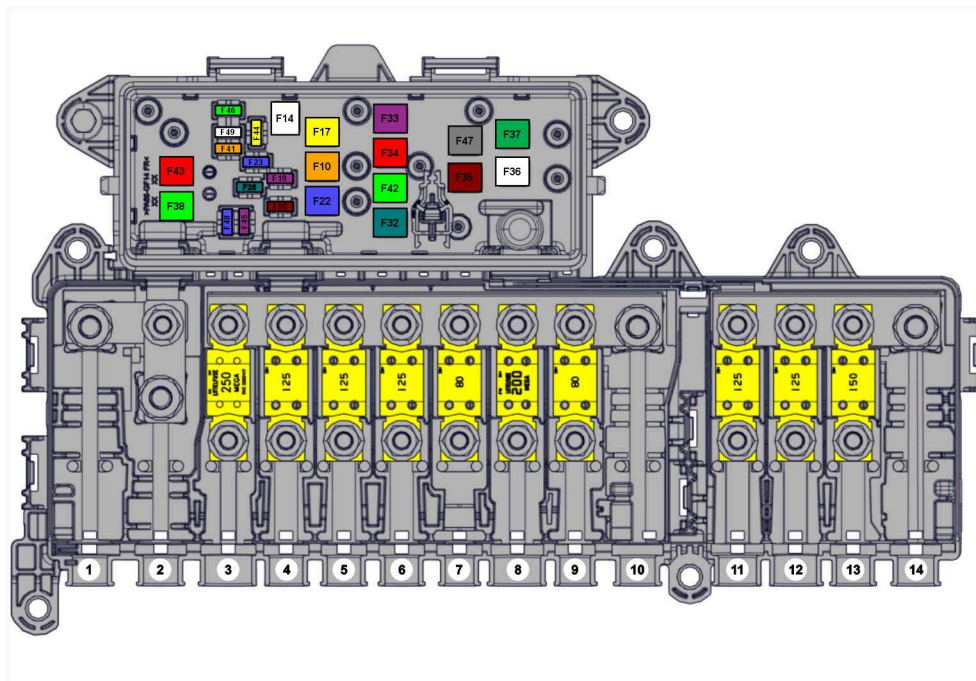

T3211832

Fuses

Fuse position	Fuse Number	Rated Current in Ampere (A)	Voltage in Volts [V]	Function
1	–	–	24	Starter
2	–	–	24	Ultra capacitor (applicable for DESS (Dual Energy Storage System))
3	FB02	200	24	Alternator
4	FB03	125	24	Cab FRC (Fuse and Relay Center)
5	FB04	125	24	EFRC (External Fuse and Relay Center)
6	FB06	125	24	Spare
7	FB05	80	24	Inverter
8	FB01	200	24	24 V bodybuilder
9	FB07	80	24	BPMU (Battery Power Management Unit)
10	–	–	24	24 V battery
11	F30	125	12	BPMU (Battery Power Management Unit)
12	F31	125	12	Spare
13	F29	150	12	12 V bodybuilder
14	–	–	12	12 V battery

Fuse number	Relay rating in Ampere [A]	Voltage in Volts [V]	Function
F38	40	24	BPMU applicable for DESS (Dual Energy Storage System)
F43	40	24	Spare (DESS) only
F32	40	12	TBIOM power supply -1
F42	40	12	TBIOM power supply -4
F34	40	12	TBIOM power supply -3
F33	40	12	TBIOM power supply -2
F45	10	24	Spare
F50	10	24	Spare
F26	10	24	APM (Air Production Modulator)
F19	20	24	ABS (Anti-lock Brake System)/ EBS (Electronically controlled Brake System)
F23	20	24	Spare
F48	10	24	Spare
F46	10	24	Spare
F44	10	24	Spare
F49	20	24	Spare
F41	20	24	Spare
F35	30	12	Bodybuilder Predisposal
F47	40	12	Spare
F36	60	12	Spare
F37	60	12	Spare
F22	40	12	Spare
F10	30	24	FCIOM (Front Chassis I/O Module) power supply
F17	30	24	FAS (Front Axle Steering) power supply
F14	30	24	RCIOM (Rear Chassis I/O Module) power supply

BBEC (Body Builder Electrical Center)

The BBEC is mounted on the bracket near the dashboard panel.

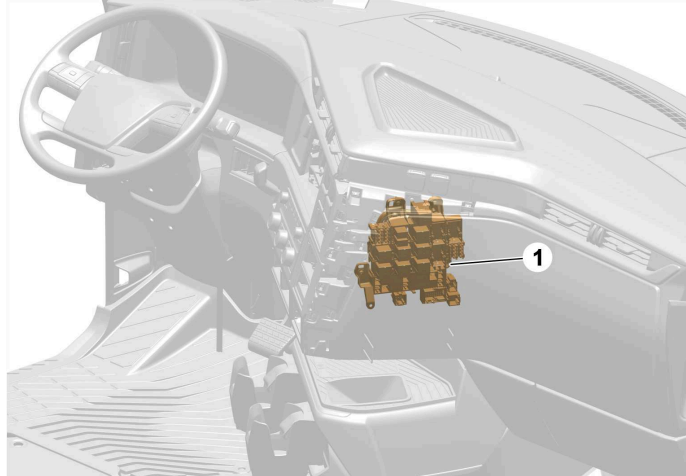

T3204719

1. BBEC location

BBEC Connectors details

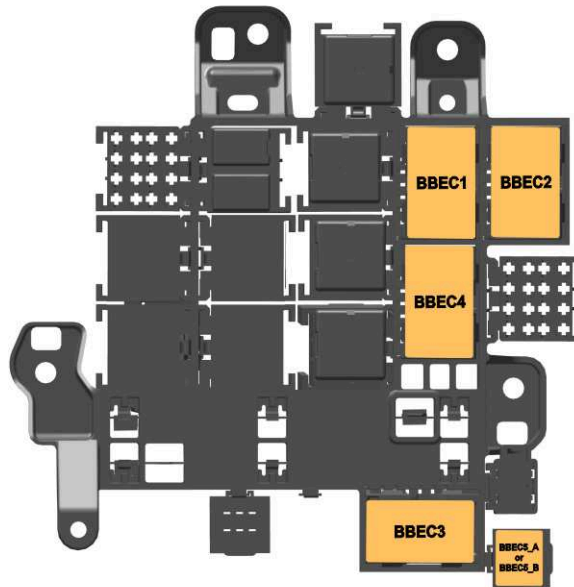

T3207973

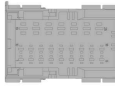

T3207974

BBEC 25 Pin Connector

Mating Connector Details

Blue connector – 995632 (Vendor - 1-2141846-3)
 Insert - 20716731 (vendor - 1718489-1) for cavity 1-18 Terminal - 991610
 Insert - 20716730 (vendor - 1718488-1) for cavity 19-25 Terminal - 984975.

BBEC1

Pin number	Pin Name/Description
1	AuxDO1 (VMCU DOH 24V)
2	AuxDO2 (VMCU DOH 24V)
3	Vehicle speed pulse
4	-
5	Roof light supply
6	Extra spot lamp front relay control
7	Trailer body light EL8 relay supply
8	Extra parking light relay control (Snowplow Relay Control)
9	Hardwired Aux Switch Backlight
10	-
11	Tail lift / Crane enable
12	-
13	Hardwired Aux Switch Ground
14	Hardwired Aux Switch Relay Control
15	-
16	-
17	Engine running signal (opt :neutral, park brake)
18	-
19	Flexible AUX Sw 2 output
20	Flexible AUX Sw 4 output
21	-
22	BBEC ignition supply
23	-
24	-
25	Hardwired Aux Switch Power (12V)

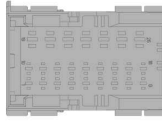

T3207974

BBEC 25 Pin Connector

Mating Connector Details

Green Connector - 995632 (Vendor - 1-2141846-4)

Insert - 20716731 (vendor - 1718489-1) for cavity 1-18 Terminal - 991610

Insert - 20716730 (vendor - 1718488-1) for cavity 19-25 Terminal - 984975.

BBEC2

Pin number	Name/Description
1	ProgLogics 7 - Parking Brake Status
2	Body Indicator / BB RSL
3	PTO2 Request
4	PTO1 Request
5	ESC Enable
6	ProgLogics 11 - Any PTO Active
7	Neutral Output
8	BB CAN High
9	BB CAN Low
10	Engine Speed Control Set / Decrease
11	Engine Speed Control Resume / Increase
12	Engine Speed Control Selector 1
13	-
14	-
15	-
16	-
17	-
18	-
19	-
20	-
21	-
22	-
23	-
24	-
25	-

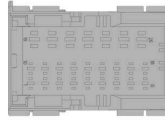

T3207974

BBEC 25 Pin Connector

Mating Connector Details

Grey Connector - 995632 (Vendor - 1-2141846-4)
 Insert - 20716731 (vendor - 1718489-1) for cavity 1-18 Terminal - 991610
 Insert - 20716730 (vendor - 1718488-1) for cavity 19-25 Terminal - 984975.

BBEC3

Pin number	Name/Description
1	-
2	-
3	-
4	-
5	-
6	-
7	-
8	-
9	Aux Switch Backlight
10	-
11	Aux Switch Backlight Ground
12	-
13	Hardwired Aux 1 input
14	Hardwired Aux 2 input
15	Hardwired Aux 3 input
16	Hardwired Aux 4 input
17	Hardwired Aux 5 input
18	Hardwired Aux 6 input
19	Hardwired Aux 1 Output
20	Hardwired Aux 2 Output
21	Hardwired Aux 3 Output
22	Hardwired Aux 4 Output
23	Hardwired Aux 5 Output
24	Hardwired Aux 6 Output
25	-

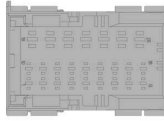

T3207974

BBEC 25 Pin Connector

Mating Connector Details

Black Connector - 995632 (Vendor - 1-2141846-1)

Insert - 20716731 (vendor - 1718489-1) for cavity 1-18 Terminal - 991610

Insert - 20716730 (vendor - 1718488-1) for cavity 19-25 Terminal - 984975.

BBEC4

Pin number	Pin Name/Description
1	-
2	-
3	-
4	-
5	-
6	-
7	-
8	-
9	-
10	-
11	-
12	-
13	-
14	-
15	-
16	-
17	-
18	-
19	Hardwired Aux 1 Output
20	Hardwired Aux 2 Output
21	Hardwired Aux 3 Output
22	Hardwired Aux 4 Output
23	Hardwired Aux 5 Output
24	Hardwired Aux 6 Output
25	-

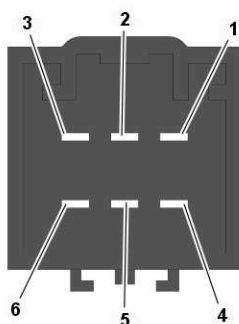

T3207975

BBEC – 6 Pin Connector

Mating Connector Details

Mating Connector – 21138421

Connector- 21138450

Terminal- 993723

BBEC5_A

Pin number	12V Pin Name/Description
1	12V BB1 PDC OUT Living supply1
2	12V BB1 PDC OUT Living supply2
3	12V BB1 PDC OUT Pre-running supply3
4	12V BB1 PDC OUT Pre-running supply4
5	12V BB1 PDC OUT Pre-running supply5
6	12V battery supply2

Note: This table is only applicable when 12 V BBEC is ordered.
The 12V BBEC will have red wires inserted in the connector.

BBEC5_B

Pin number	24V Pin Name/Description
1	8026 - BBEC Main power supply 1 (30 A power supply)
2	8027 - BBEC Ignition power supply (30 A power supply)
3	8028 - BBEC Battery power supply (40 A power supply)
4	-
5	-
6	-

Note: This table is only applicable when 24 V BBEC is ordered.
The 24V BBEC will have yellow wires inserted into the connector.

BBEC fuse and relays

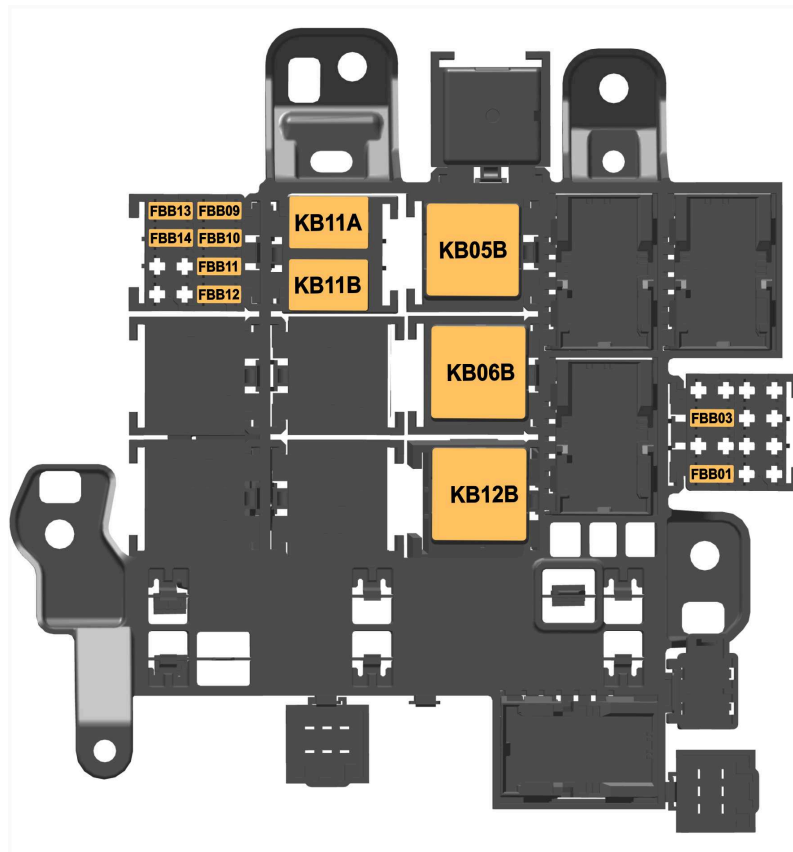

T3204720

Fuses

Fuse number	Fuse rating in Ampere [A]	Function
FBB01	15	Aux 4 (power distribution Center: ignition)
FBB03	10	PTO indicator
FBB09	10	Hardwired aux switches 4
FBB10	10	Hardwired aux switches 3
FBB11	10	Hardwired aux switches 2
FBB12	10	Hardwired aux switches 6
FBB13	10	Hardwired aux switches 1
FBB14	10	Hardwired aux switches 5

Relays

Relay number	Relay rating in Ampere [A]	Function
KB05B	20	Aux 2
KB06	20	Aux 4 (power distribution Center: ignition)
KB11A	10	PTO Neutral indicator
KB11B	10	PTO active indicator
KB12	40	Hardwired Aux switches 1, 2, and 3 Relay

Front Chassis I/O Module (FCIOM)

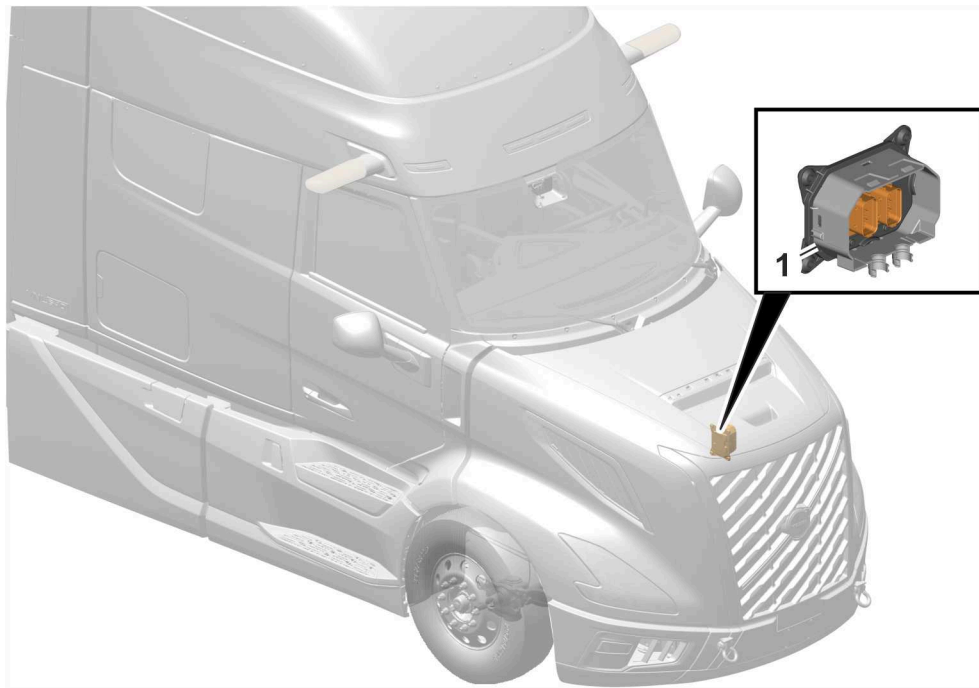

T3217390

FCIOM Component location

The FCIOM is an interface to the components placed on the front end of the chassis and regulates power distribution. The FCIOM is in the lower front area (left-hand side) of the truck. The fuses FE02 and FB10 supply power to the FCIOM. The FCIOM is connected with the CAN (Controller Area Network) chassis subnet.

The FCIOM controls the following functions

- All exterior lights in the front
- Fluid level sensor (washer)
- Pump motor (washer)
- Ambient temperature sensor
- Electric horn
- Air horn
- Headlamp de-icing.

Description of FCIOM Signals

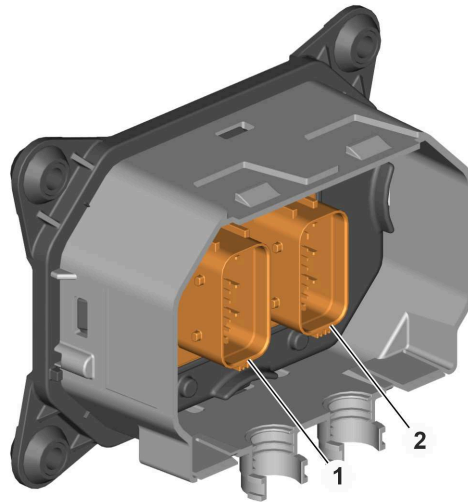

T3215969

- 1 Connector X1
- 2 Connector X2

Notes

FCIOM Connectors

1. X1

Pin	Description
CX1:1	CAN HIGH
CX1:2	—
CX1:3	DRL OUTER POSITION FRONT RIGHT
CX1:4	FOG LAMP LEFT
CX1:5	CAN HIGH
CX1:6	DRL OUTER POSITION FRONT LEFT
CX1:7	FOG LAMP RIGHT
CX1:8	DRL INNER POSITION FRONT LEFT
CX1:9	—
CX1:10	—
CX1:11	—
CX1:12	HEADLIGHT DE-ICING BULB
CX1:13	—
CX1:14	—
CX1:15	—
CX1:16	LOW BEAM RIGHT
CX1:17	IGNITION
CX1:18	—
CX1:19	CORNER/DRIVING LIGHT LEFT
CX1:20	HIGH BEAM LEFT
CX1:21	—
CX1:22	HAZARD HARDWIRE
CX1:23	OUTER FRONT TURN INDICATOR RIGHT
CX1:24	INNER FRONT TURN INDICATOR LEFT
CX1:25	—
CX1:26	—
CX1:27	—
CX1:28	GROUND
CX1:29	—

2. X2

Pin	Description
CX2:1	INNER FRONT TURN INDICATOR RIGHT
CX2:2	OUTER FRONT TURN INDICATOR LEFT
CX2:3	—
CX2:4	—
CX2:5	HIGH BEAM RIGHT
CX2:6	DRL INNER POSITION FRONT RIGHT
CX2:7	WINDSCREEN WASHER PUMP
CX2:8	FRONT SIDE MARKER LIGHT
CX2:9	CORNER/DRIVING LIGHT RIGHT
CX2:10	—
CX2:11	AUXILLIARY HORN
CX2:12	CITY HORN
CX2:13	LOW BEAM LEFT
CX2:14	—
CX2:15	AMBIENT TEMPERATURE. GROUND
CX2:16	AMBIENT TEMPERATURE. SENSOR.
CX2:17	AMBIENT TEMPERATURE 2 SENSOR
CX2:18	—
CX2:19	WASHER FLUID SENSOR. GROUND
CX2:20	WASHER FLUID SENSOR
CX2:21	—
CX2:22	—
CX2:23	—
CX2:24	—
CX2:25	—
CX2:26	—
CX2:27	—
CX2:28	GROUND
CX2:29	—

Trailer body I/O module (TBIOM)

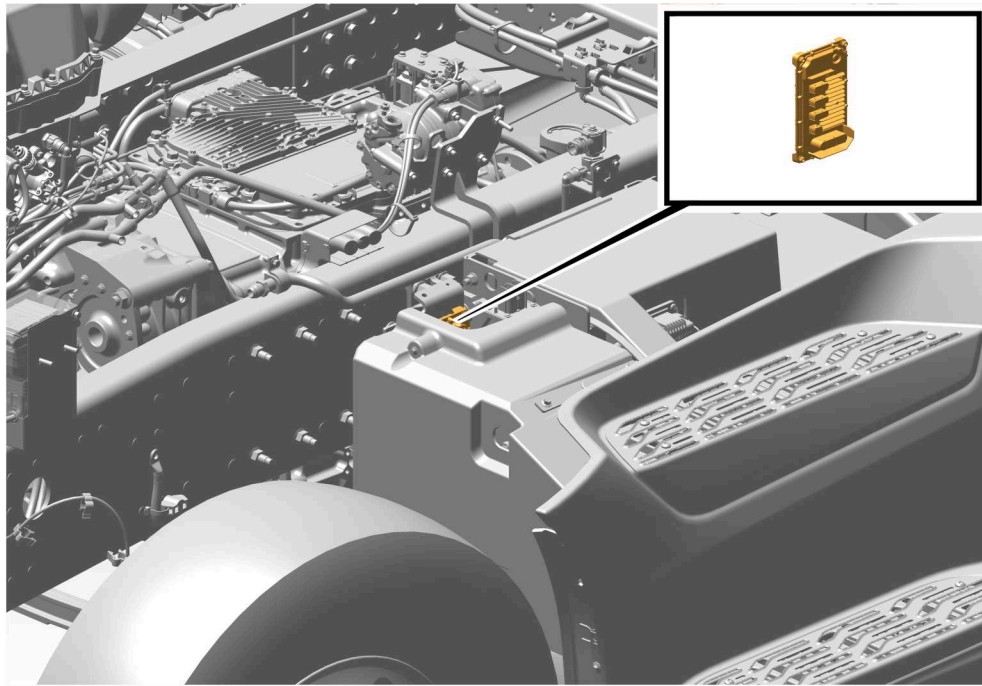

T3208030

TBIOM Component location

The TBIOM is the interface to support 12 V trailer light and some body builder functions connected to a 24 V truck. The TBIOM is connected to the trailer connector through the SAE J560 connectors. The TBIOM has a micro controller and circuit for handling the 24 V inputs. The TBIOM has outputs of 12 V, 5 V and CAN (Controller Area Network) communication. TBIOM is inside the power box, which is installed on the chassis.

The TBIOM controls the following functions

- Position lights
- Direction indicator
- Hazard warning lights
- Reverse lights
- Brake lights
- Extra BB (Body Builder) functions - auxiliary switches

Description of TBIOM Signals

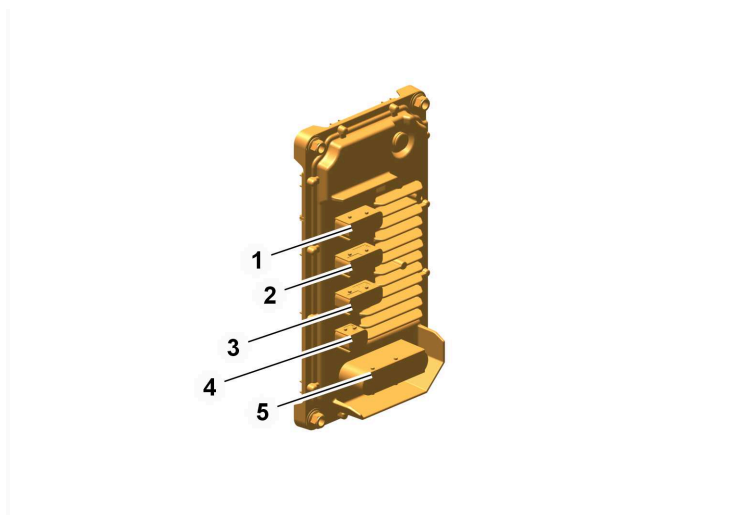

T3208031

- 1 CN1
- 2 CN2
- 3 CN3
- 4 CN4
- 5 CN5

TBIOM Connectors

1. CN1

Pin	Description
CN1:1	Brake light switch
CN1:2	Ignition
CN1:3	Hazard
CN1:4	—
CN1:5	—
CN1:6	—
CN1:7	CAN L
CN1:8	CAN H
CN1:9	PLC
CN1:10	—
CN1:11	—
CN1:12	—
CN1:13	—
CN1:14	—
CN1:15	—

2. (CN2)

Pin	Description
CN2:1	Trailer turn indicator right
CN2:2	Trailer position light 1
CN2:4	Trailer position light 2
CN2:5	Trailer turn indicator right
CN2:7	Trailer power supply with PLC
CN2:8	Trailer turn left

3. CN3

Pin	Description
CN3:1	Auxiliary digital output 9
CN3:2	BB reverse light
CN3:3	BB brake light
CN3:4	Auxillary 2
CN3:5	BB position light 1
CN3:6	BB position light 2
CN3:7	–
CN3:8	–
CN3:9	Turn indicator right
CN3:10	Turn indicator left
CN3:11	BB turn left/ brake light
CN3:12	–
CN3:13	–
CN3:14	BB turn right/ brake light
CN3:15	Ground

4. CN4

Pin	Description
CN4:1	PWR SUPPLY BB / TRAILER
CN4:2	–

5. CN5

Pin	Description
CN5:1	KL30 Power supply 4
CN5:2	KL30 Power supply 3
CN5:3	–
CN5:4	KL30 Power supply 2
CN5:5	KL30 Power supply 1

Notes

Center chassis I/O module (CCIOM)

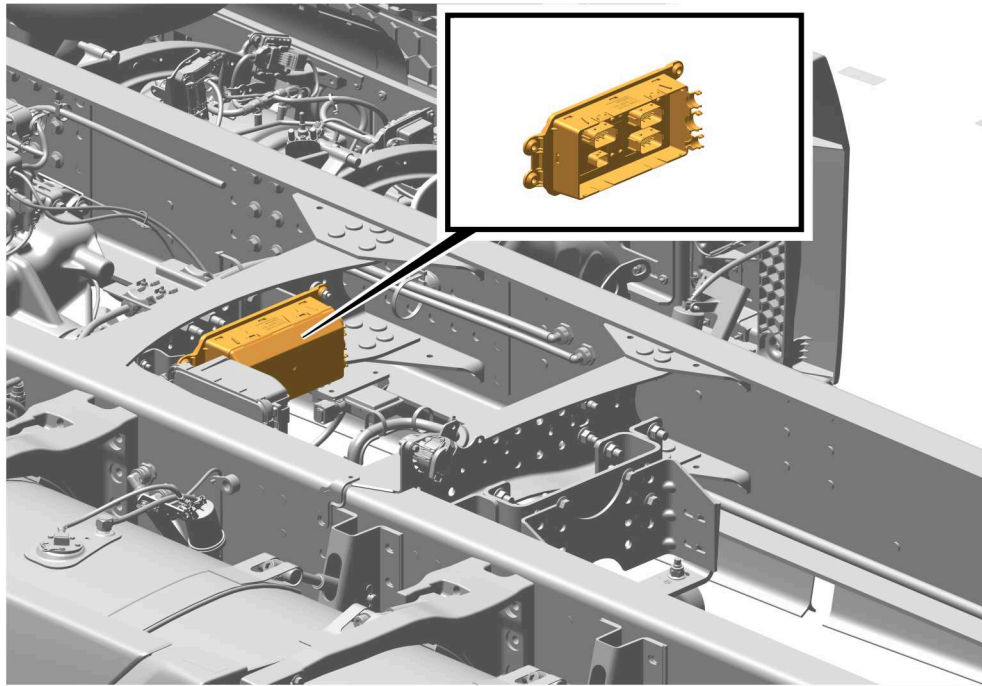

T3208032

CCIOM Component location

The CCIOM is an interface to the components placed on the middle of the chassis and regulates power distribution. The CCIOM is on the cross member behind the gearbox.

The CCIOM has the housing, the collar and a PCB (Printed Circuit Board) with the connector. The fuses of the EFRC (External Fuse and Relay Center) FE01 and FE03 supply power to the CCIOM. The CCIOM is connected with the chassis subnet.

The CCIOM controls the following functions:

- Fuel level sensor
- Battery sensor and supercapacitor are LIN (Local Interconnect Network) nodes to CCIOM
- Trailer lock/container lock
- PTO 1 (Power Take-Off) and PTO 2 valves
- Fifth wheel load lights
- APM (Air Production Modulator) redundancy power supply
- TPM (Tyre Pressure Monitoring) supply

Description of CCIOM Signals

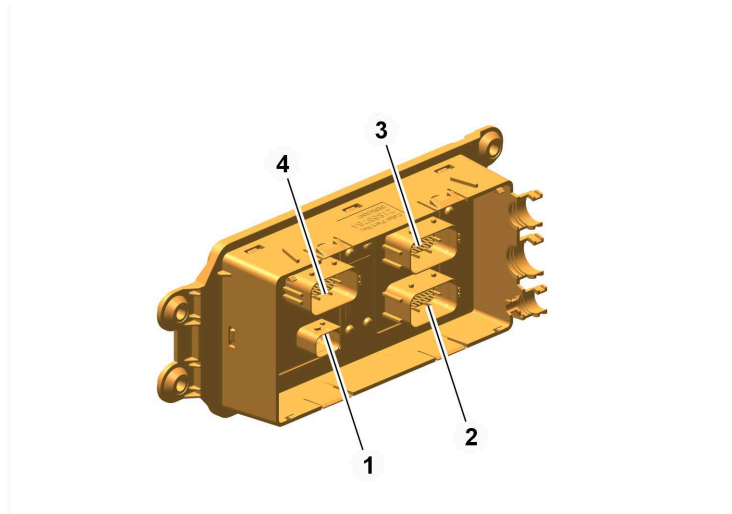

T3208033

- 1 X4
- 2 X2
- 3 X1
- 4 X3

CCIOM Connectors

1. X4

Pin	Description
CX4:1	CCIOM power supply
CX4:2	CCIOM power supply

2. X2

Pin	Description
CX2:1	–
CX2:2	PTO 1 Valve
CX2:3	–
CX2:4	–
CX2:5	5th Wheel Slide Valve Ground
CX2:6	–
CX2:7	–
CX2:8	–
CX2:9	–
CX2:10	PTO 1 FB Sensor (Only used for splitshaft PTO)
CX2:11	–
CX2:12	–
CX2:13	–
CX2:14	Main switch status
CX2:15	Fuel Level Sensor 1 Ground
CX2:16	–
CX2:17	–
CX2:18	–
CX2:19	–
CX2:20	–
CX2:21	5th Wheel Kingpin Unlock Ground
CX2:22	CAN H
CX2:23	ECS level sensor supply.2
CX2:24	–
CX2:25	BATS LINB signal
CX2:26	CAN L
CX2:27	Clearance (24V)
CX2:28	5th Wheel Load Light (24V)
CX2:29	Power ground 2

3. X1

Pin	Description
CX1:1	PTO 2 valve
CX1:2	TPM power supply
CX1:3	–
CX1:4	–
CX1:5	–
CX1:6	–
CX1:7	ECS front level sensor 1 signal
CX1:8	–
CX1:9	ECS level sensor. Ground 1
CX1:10	–
CX1:11	–
CX1:12	–
CX1:13	–
CX1:14	Fuel level sensor 1
CX1:15	Slidable 5th wheel valve (tractor) /container unlock (rigid)
CX1:16	–
CX1:17	–
CX1:18	–
CX1:19	–
CX1:20	–
CX1:21	–
CX1:22	–
CX1:23	–
CX1:24	APM redundancy power supply
CX1:25	–
CX1:26	–
CX1:27	Trailer reverse light (24V)
CX1:28	–
CX1:29	Power ground

4. X3

Pin	Description
CX3:1	–
CX3:2	–
CX3:3	–
CX3:4	–
CX3:5	–
CX3:6	–
CX3:7	5th Wheel Kignpin Unlock Solenoid 1
CX3:8	–
CX3:9	–
CX3:10	–
CX3:11	–
CX3:12	–
CX3:13	–
CX3:14	–
CX3:15	–
CX3:16	–
CX3:17	5th Wheel Kignpin Unlock Solenoid 2
CX3:18	–
CX3:19	–
CX3:20	–
CX3:21	Inside/Outside Air Intake Switch
CX3:22	–
CX3:23	–
CX3:24	–
CX3:25	–
CX3:26	–
CX3:27	–
CX3:28	–
CX3:29	–

Rear chassis I/O module (RCIOM)

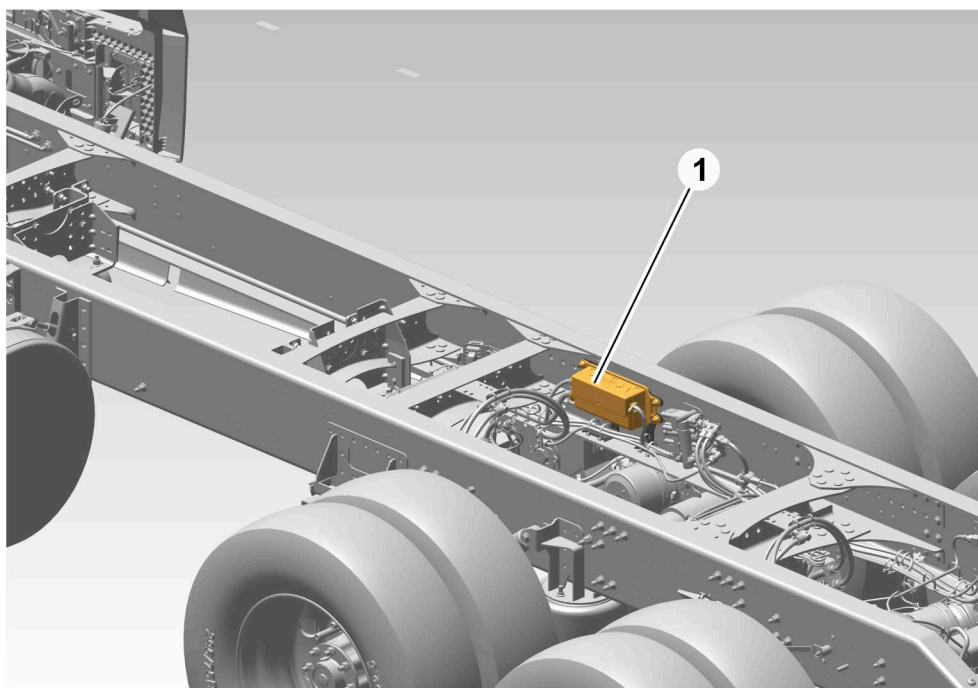

T3208034

1. RCIOM Component location

The RCIOM is an interface to the components placed on the rear end of the chassis and regulates power distribution. The RCIOM is on the cross member near to the first rear axle.

The RCIOM has the housing, the collar and a PCB (Printed Circuit Board) with the connector. The fuses FE04 and FB14 supply the power to the RCIOM. The RCIOM is connected with the chassis subnet.

The RCIOM controls the following functions:

- Rear lights and side marking lights
- Reverse warning
- Rear ECS (Electronically Controlled Suspension) (pressure and level sensor)
- Rear differential lock
- Drive axle oil temperature sensor.

Description of RCIOM Signals

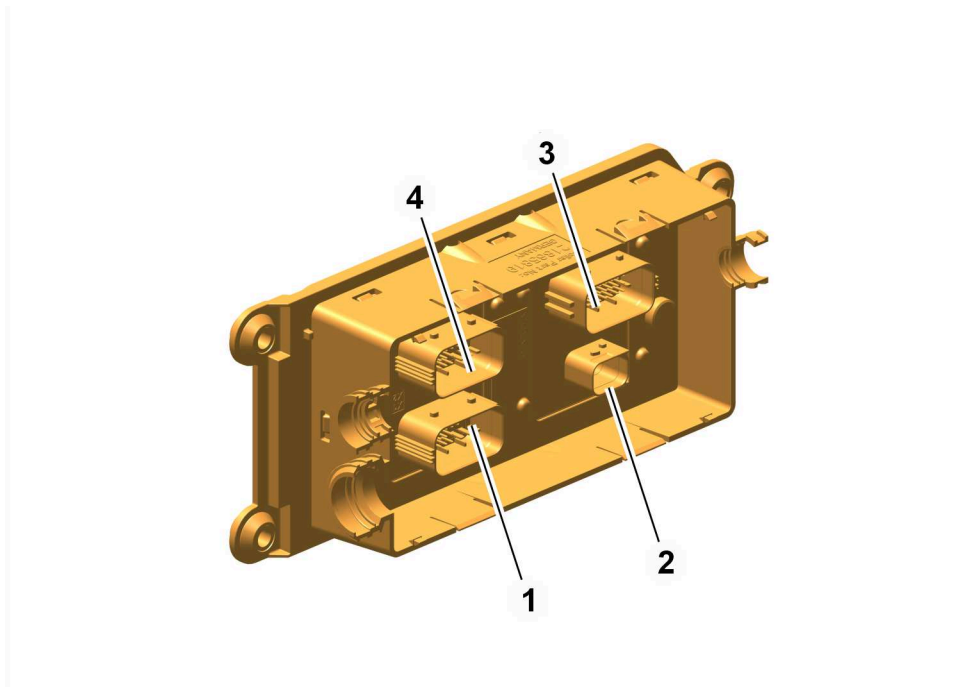

T3208035

- 1 X1
- 2 X4
- 3 X3
- 4 X2

RCIOM Connectors

1. X1

Pin	Description
CX1:1	–
CX1:2	–
CX1:3	Trailer Position Lamp Right 24V Work lamp, if 24V version of RP170 is selected
CX1:4	Rear Wheel Diff. Lock Valve 1
CX1:5	Spare
CX1:6	Hazard hardwired
CX1:7	Trailer ABS power 24V Trailer/Marker, if 24V version of RP170 is selected
CX1:8	–
CX1:9	–
CX1:10	Axle-1 Oil Temp Sensor
CX1:11	Axle-2 Oil Temp Sensor
CX1:12	Ignition signal
CX1:13	–
CX1:14	Axle Temperature Sensor Ground
CX1:15	–
CX1:16	Rear inter axle differential lock valve on/off
CX1:17	Side Marker/ Turn Ind Left
CX1:18	–
CX1:19	–
CX1:20	Trailer Position Lamp Left 24V Strobe, if 24V version of RP170 is selected
CX1:21	Side Marker/ Turn Ind Right
CX1:22	CAN L
CX1:23	CAN H
CX1:24	Trailer turn right 24V right turn/stop(5A), if 24V version of RP170 is selected
CX1:25	Trailer turn left 24V left turn/stop(5A), if 24V version of RP170 is selected
CX1:26	Trailer brake lamp 24V stop lamp(5A), if 24V version of RP170 is selected
CX1:27	ECU Ground
CX1:28	ECU Ground
CX1:29	–

2. X4

Pin	Description
CX4:1	RCIOM power supply
CN2:2	RCIOM power supply

3. X3

Pin	Description
CX3:1	ECS rear pressure sensor supply 1
CX3:2	ECS rear level sensor supply 2
CX3:3	ECS rear solenoid valve 5
CX3:4	ECS rear solenoid valve 4
CX3:5	ECS pressure sensor signal 5
CX3:6	ECS pressure sensor signal 6
CX3:7	ECS rear solenoid valve 6
CX3:8	ECS rear solenoid valve 7
CX3:9	ECS rear level signal 1
CX3:10	ECS rear level signal 2
CX3:11	ECS rear pressure ground
CX3:12	ECS rear level ground
CX3:13	ECS rear pressure signal. 1
CX3:14	ECS rear pressure signal. 2
CX3:15	–
CX3:16	–
CX3:17	ECS pressure sensor signal 3
CX3:18	ECS pressure sensor signal 4
CX3:19	ECS rear solenoid valve 9
CX3:20	ECS rear solenoid valve 8
CX3:21	–
CX3:22	ECS pressure sensor signal 7
CX3:23	ECS rear valve 2
CX3:24	ECS rear valve 1
CX3:25	ECS rear valve 3
CX3:26	–
CX3:27	–
CX3:28	ECS solenoid valves return 2
CX3:29	ECS solenoid valves return 1

4. X2

Pin	Description
CX2:1	Right rear turn lamp
CX2:2	Brake lamp left
CX2:3	–
CX2:4	Position lamp rear right
CX2:5	–
CX2:6	–
CX2:7	–
CX2:8	–
CX2:9	Rear wheel axle switch 2
CX2:10	–
CX2:11	Brake lamp right
CX2:12	–
CX2:13	–
CX2:14	Rear wheel axle switch 3
CX2:15	Axle-3 oil temperature sensor
CX2:16	B/U lamp rear
CX2:17	–
CX2:18	Rear wheel differential lock valve 2
CX2:19	–
CX2:20	–
CX2:21	–
CX2:22	Rear wheel axle switch 1
CX2:23	B/U WARNING
CX2:24	Position lamp rear left
CX2:25	Rear turn left
CX2:26	–
CX2:27	–
CX2:28	–
CX2:29	–

Notes

Vehicle Master Control Unit (VMCU)

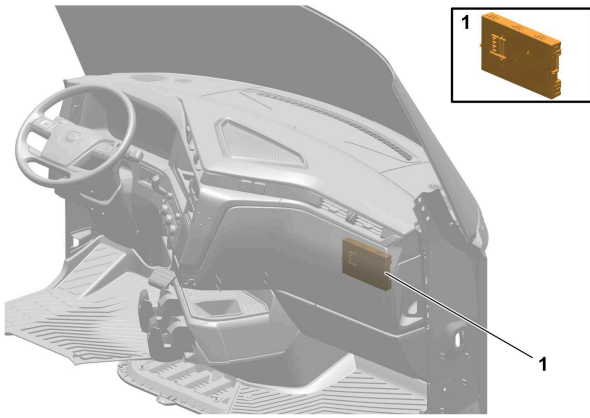

T3203568

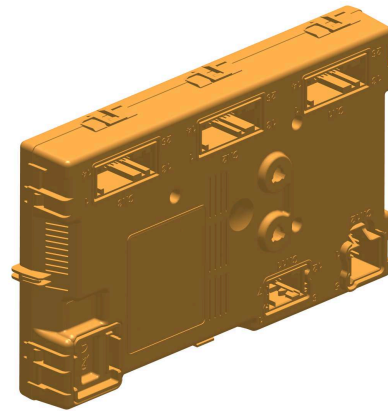

T3201038

1. VMCU

The VMCU is connected to the FRC (Fuse and Relay Center) and is in the dashboard. The VMCU receives 24 V power from the batteries through the fuses in the FRC. The VMCU is a master control unit that controls the other control units connected through backbone 1 and backbone 2. The VMCU has an OBD (On-Board Diagnostics) connector, which helps for diagnostic purposes.

The VMCU controls the following functions:

- Accelerator pedal sensor
- Vehicle speed sensor
- Starter key or passive start/stop
- Brake lamps
- Interior and exterior lamps
- Washer and wiper functions
- Body builder functions
- Relay for vision camera, refrigerator etc
- Controller of the vehicle modes (Hibernate, Parked, Living, Accessory, Pre-running, Crank, and Running).
- Vehicle Speed Sensor (VSS)

Description of VMCU Signals

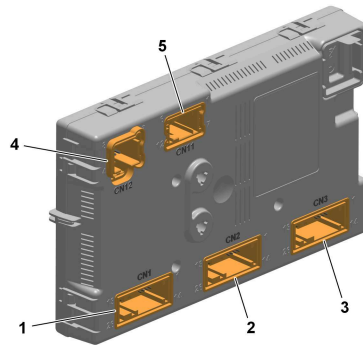

T3203350

- 1 CN1
- 2 CN2
- 3 CN3
- 4 CN12
- 5 CN11

VMCU Connectors

1. CN1

Pin	Description
CN1:1	Vehicle speed 8 pulse
CN1:2	12 V supply for external LIN sensor
CN1:3	GND for external LIN sensor
CN1:4	Switch backlight GND 1
CN1:5	Rain sensor LIN signal
CN1:6	Switch backlight GND 2
CN1:7	LIN 23/Stalk module
CN1:8	Spare
CN1:9	Resting light circuit 2
CN1:10	Ignition signal cab
CN1:11	Extra spot lamps front cab
CN1:12	Accessories signal
CN1:13	Cup holder light
CN1:14	Switch backlight GND 3
CN1:15	Spare
CN1:16	Spare
CN1:17	Spare
CN1:18	Rain sensor ground
CN1:19	resting light circuit 2
CN1:20	Night driving light circuit

Pin	Description
CN1:21	Headshelf backlight
CN1:22	Bunk backlight
CN1:23	Body builder backlight
CN1:24	Spare
CN1:25	Spare
CN1:26	Hazard switch light

2. CN2

Pin	Description
CN2:1	PWM 2 Spare
CN2:2	CAN 6 H Spare
CN2:3	CAN 6 L Spare
CN2:4	Spare GND
CN2:5	Front side direction indicator CAT 6 left
CN2:6	LSD Spare 1
CN2:7	Extra spot lamps front chassis
CN2:8	AI 1 Spare
CN2:9	Surround light
CN2:10	AI GND Spare
CN2:11	Spare
CN2:12	Extra parking lights chassis
CN2:13	Amber LED supply lights chassis
CN2:14	Spare
CN2:15	Digital input Spare 1
CN2:16	Digital input Spare 2
CN2:17	Spare
CN2:18	Spare
CN2:19	Vehicle Speed Sensor supply
CN2:20	Vehicle Speed Sensor POS
CN2:21	Vehicle Speed Sensor ground
CN2:22	CAN L
CN2:23	CAN H
CN2:24	Ignition signal chassis
CN2:25	Hazard hardwired chassis
CN2:26	Front side direction indicator CAT6 Right

3. CN3

Pin	Description
CN3:1	OBD 2 proprietary CAN H
CN3:2	OBD 2 proprietary CAN L
CN3:3	Hazard swand LED GND
CN3:4	Backbone 2 CAN H
CN3:5	Backbone 2 CAN L
CN3:6	Accelerator pedal ground 1
CN3:7	Backbone 1 CAN H
CN3:8	Backbone 1 CAN L
CN3:9	Accelerator pedal ground 2
CN3:10	Accelerator pedal 2
CN3:11	Accelerator pedal supply 1
CN3:12	CAN5 H Spare
CN3:13	Hazard sitch
CN3:14	Key IN/OUT
CN3:15	Key C
CN3:16	CAN5 L Spare
CN3:17	Digital input Spare 3
CN3:18	Road speed limit
CN3:19	Key REF
CN3:20	Accelerator pedal supply 1
CN3:21	GND
CN3:22	Ket B
CN3:23	Key A
CN3:24	Remote immobilizer R
CN3:25	
CN3:26	

4. CN12

Pin	Description
CN12:1	Resting light circuit 1
CN12:2	Maximum light circuit 2 White LED supply Start and Stop button
CN12:3	PWM 3 Spare
CN12:4	Maximum light circuit 1
CN12:5	Spare
CN12:6	PWR 24 V 21 Spare
CN12:7	Maximum light circuit 1 and 2 GND
CN12:8	Position light circuit

5. CN11

Pin	Description
CN11:1	Side/Reverse working lights
CN11:2	Tail lift Enable/Crane
CN11:3	Engine Run/Neutral/Park brake
CN11:4	Warning Body/Tail lift feedback
CN11:5	Green LED supply Start and Stop button
CN11:6	Extra spot lamps front BB
CN11:7	Cab/Body working lamps
CN11:8	Auxiliary Digital Output 2 (AuxDO2)
CN11:9	Auxiliary Digital Output 1 (AuxDO1)
CN11:10	Digital input Spare 4
CN11:11	Extra parking light BB
CN11:12	Digital input Spare 5

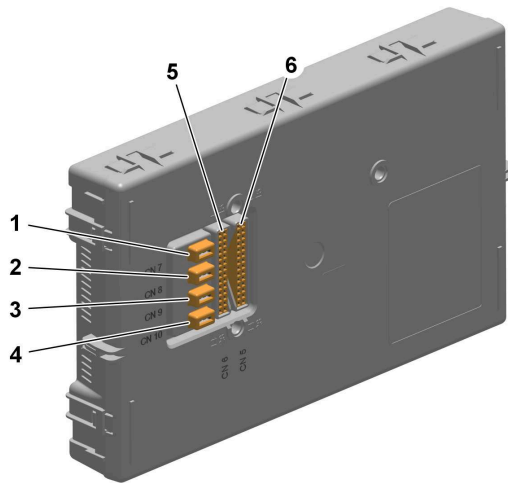

T3203349

- 1 CN7
- 2 CN8
- 3 CN9
- 4 CN10
- 5 CN6
- 6 CN5

1 – 4. CN7, CN8, CN9, CN10

Pin	Description
CN7	VMCU supply 3
CN8	GND
CN9	VMCU supply 1
CN10	VMCU supply 2

5. CN6

Pin	Description
CN6:1	Spare
CN6:2	Spare
CN6:3	Front wiper On/Off relay
CN6:4	Front wiper High/Low relay
CN6:5	Accessories signal
CN6:6	Sensor/Switch GND
CN6:7	Windscreen wiper park position
CN6:8	Position light circuit
CN6:9	Position light circuit
CN6:10	AI 4 Spare
CN6:11	5 V SUP 3 Spare
CN6:12	Resting light circuit 2
CN6:13	Maximum light circuit 2
CN6:14	Maximum light circuit 1
CN6:15	Night driving light circuit
CN6:16	Ignition signal cab
CN6:17	Headshelf sensor position
CN6:18	Vehicle speed sensor position
CN6:19	EMS supply fuse output
CN6:20	Spare
CN6:21	Refrigerator relay
CN6:22	Resting light circuit 1
CN6:23	Resting light circuit 1
CN6:24	Spare 4 relay
CN6:25	Sunroof motor 1 relay
CN6:26	Sunroof motor 2relay
CN6:27	Maximum light circuit 2
CN6:28	Maximum light circuit 2

6. CN5

Pin	Description
CN5:1	TECU relay
CN5:2	BB ignition relay
CN5:3	Spare 1 relay
CN5:4	Spare 7 relay
CN5:5	Engine Management (EMS) relay
CN5:6	Spare
CN5:7	Spare
CN5:8	Seats movement relay
CN5:9	Ignition relay
CN5:10	Trailer body lighting relay
CN5:11	Headlight washer pump relay
CN5:12	Mirror heating relay
CN5:13	CMS relay
CN5:14	Spare 6 relay
CN5:15	Power supply 3 relay
CN5:16	Power supply 4 relay
CN5:17	Accessories relay
CN5:18	Power supply 2 relay
CN5:19	Extra spotlamps roof relay
CN5:20	Beacon warning lamps relay
CN5:21	Engine running relay
CN5:22	Roof light signal relay
CN5:23	5 V SUP 1 Spare
CN5:24	AI 2 Spare
CN5:25	AI 3 Spare
CN5:26	5 V SUP 2 Spare
CN5:27	Sensor/Switch GND
CN5:28	Full beam inside sign area relay

Notes

Supplemental Restraint System

Volvo vehicles may be equipped with the Supplemental Restraint System (SRS). The SRS is supplemental protection for use together with the safety belt. The SRS is designed to reduce the risk of injury to the driver's face and upper body.

The system consists of an inflatable bag mounted in the center of the steering wheel, and a control unit mounted inside the cab. A chemical based gas generator attached to the rear of the bag inflates the bag in the event of a collision.

The sensors in the control unit detect deceleration. If the control unit detects a sufficiently violent deceleration (collision), the system is activated. The gas generator activates and fills the bag with a harmless gas within a few hundredths of a second. During a collision, after the bag has been filled, the gas flows out through two holes in the back of the bag. These holes are large enough to let the airbag collapse slowly, gently catching the driver.

The control unit also contains a standby power unit which can supply the system with power for a short time should the normal power supply be broken.

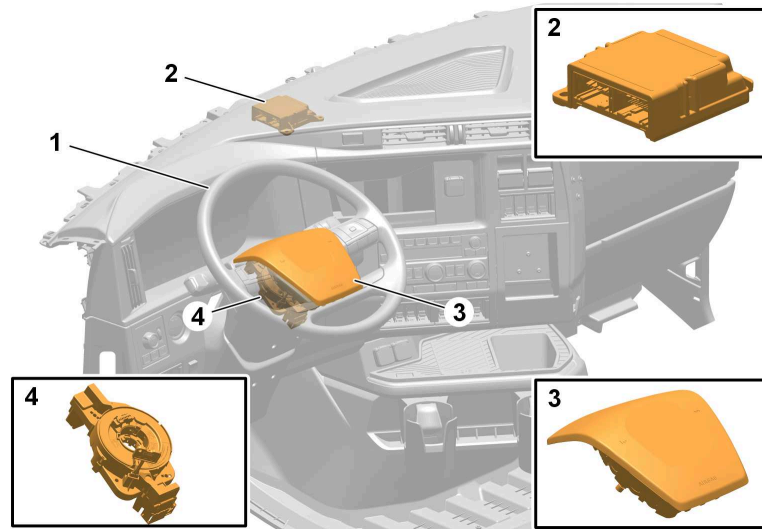

T3201030

- 1 Steering wheel
- 2 Airbag module
- 3 Contact reel
- 4 SRS control unit

Climate Control Module

Note: For basic operator information about the climate control system, refer to the Drivers Manual.



CAUTION

DO NOT interface to, modify, or alter any of the sensors or circuits used by the CCM system. Refer to the A/C service manual for all service information.

Whenever the vehicle is equipped with air conditioning, either an Electronic Climate Control (ECC) or Manual Climate Control (MCC) ECU will be used to operate the front (dash) HVAC system. Both systems directly control the A/C compressor and HVAC blower, as well as offering diagnostic service codes which are readable using the instrument cluster.

Both systems receive information from other ECUs over the J1939 and J2284 databus, such as outdoor (ambient) temperature, vehicle speed, and engine operating conditions.

The ECC system includes a fully automatic mode of operation. The driver sets the desired temperature, and the system will automatically select the best mode (A/C, air outlet control, blower speed, etc.) to reach that temperature in the most comfortable way. An in-cab temperature sensor is located in the center dash panel, to the right of the ashtray. In addition to the automatic mode, full manual control of the HVAC system is possible.

The MCC system is fully manual (both blower speed and air outlet control). No in-cab temperature sensor is used.

Neither the ECC nor MCC systems has any interaction or control over the bunk HVAC system, which is controlled by the CCP (Climate Control Panel) integrated in the DECM (Driver-Environment Control Module).

Engine Electronics

The EMS (Engine Management System) electronically controls the fuel system for precise fuel injection. The central part of the EMS system is the ECM. The ECM is mounted on the vibration-damping rubber elements, which reduces the vibrations acting on the ECM. The ECM requires continuous information from the accelerator pedal and various sensors to control the amount of fuel injection and timing of injection for optimal engine performance.

The ECM has a microprocessor and software that process the electrical signals from the engine sensors. The ECM uses this information to control the fuel injectors through the solenoids. In addition, the ECM performs diagnostic functions.

Certain features of the engines are programmable using a service tool. For Volvo engines, Premium Tech Tool 2 must be used to program these engine features. Information on adjustable parameters in the Volvo engine is included in the ECM programming section.

Instrument Cluster

Note: For basic operator information about the instrument cluster, refer to the Drivers Manual.

The DID (Driver Information Display) in the instrument cluster is used to display menus, vehicle messages and other information. A default view is displayed when the favorite display is not used for menus or messages. The driver can use the favorite display function to select which elements must be displayed in the information view. When the drivers choose the data to display, it is saved and used in place of the default information. The favorite display is set using the SWS.

Component location

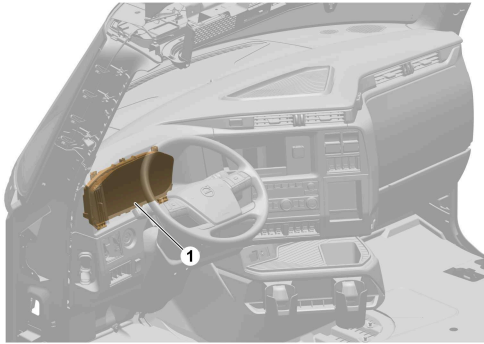

T3201032

1. Instrument cluster

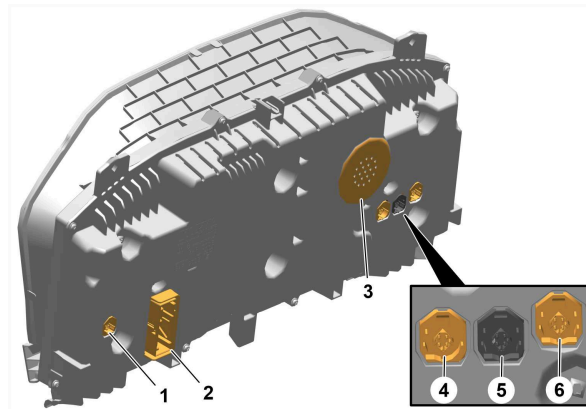

T3201033

- 1 OBD connector
- 2 Main connector
- 3 Speaker
- 4 TGW connector
- 5 Chassis switch connector
- 6 Camera connector

Exterior Light Control Panel

The Exterior Light Control Module (ELCP) controls all exterior lighting functions separately from the interior lighting in the cab and optional extras installed on the vehicle.

The exterior lighting increases visibility for the driver and allows other drivers and pedestrians to see the presence, position, size and direction of travel of the vehicle.

The electrical components of exterior lighting have the following:

- ELCP
- FCIOM
- RCIOM
- Direction indicator stalk module
- Headlamp assemblies
- Fog lamps
- Roof marker (clearance) lamps
- Direction indicator (repeater) lamps
- Tail lamps
- Back of cab lamp
- Trailer connector.

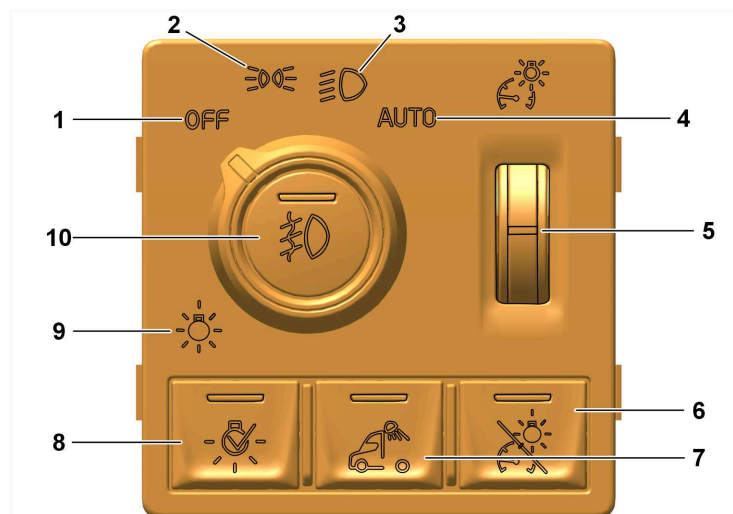

T3206081

- | | |
|-----------------------------|------------------------------------|
| 1. OFF | 6. Day/night pre-set (black panel) |
| 2. Position lamp | 7. Back of cab lamp |
| 3. Dipped beam (headlamp) | 8. Exterior lamp check |
| 4. Headlamp automatic | 9. ELCP identifier symbol |
| 5. Dashboard dimmer control | 10. Fog lamp |

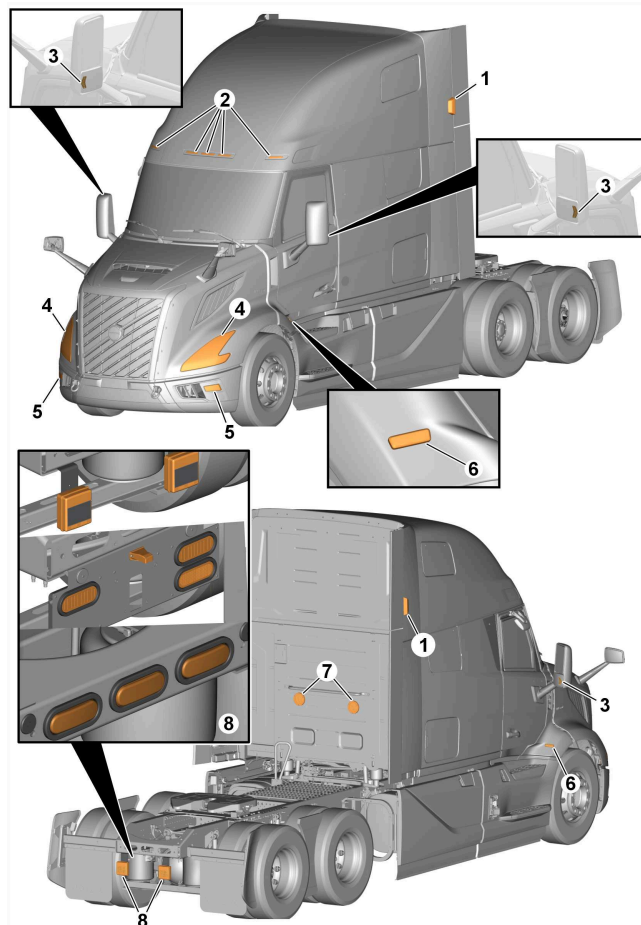

T3203387

Sl no.	Description
1	Work lamp (installed outer side of the deflector)
2	Roof marker (clearance) lamp
3	Direction indicator (mirror left/right)
4	Headlamp
5	Fog and driving lamp
6	Direction indicator (repeater) lamp
7	Work lamp (installed back side of the cab)
8	Tail lamps

Schematics

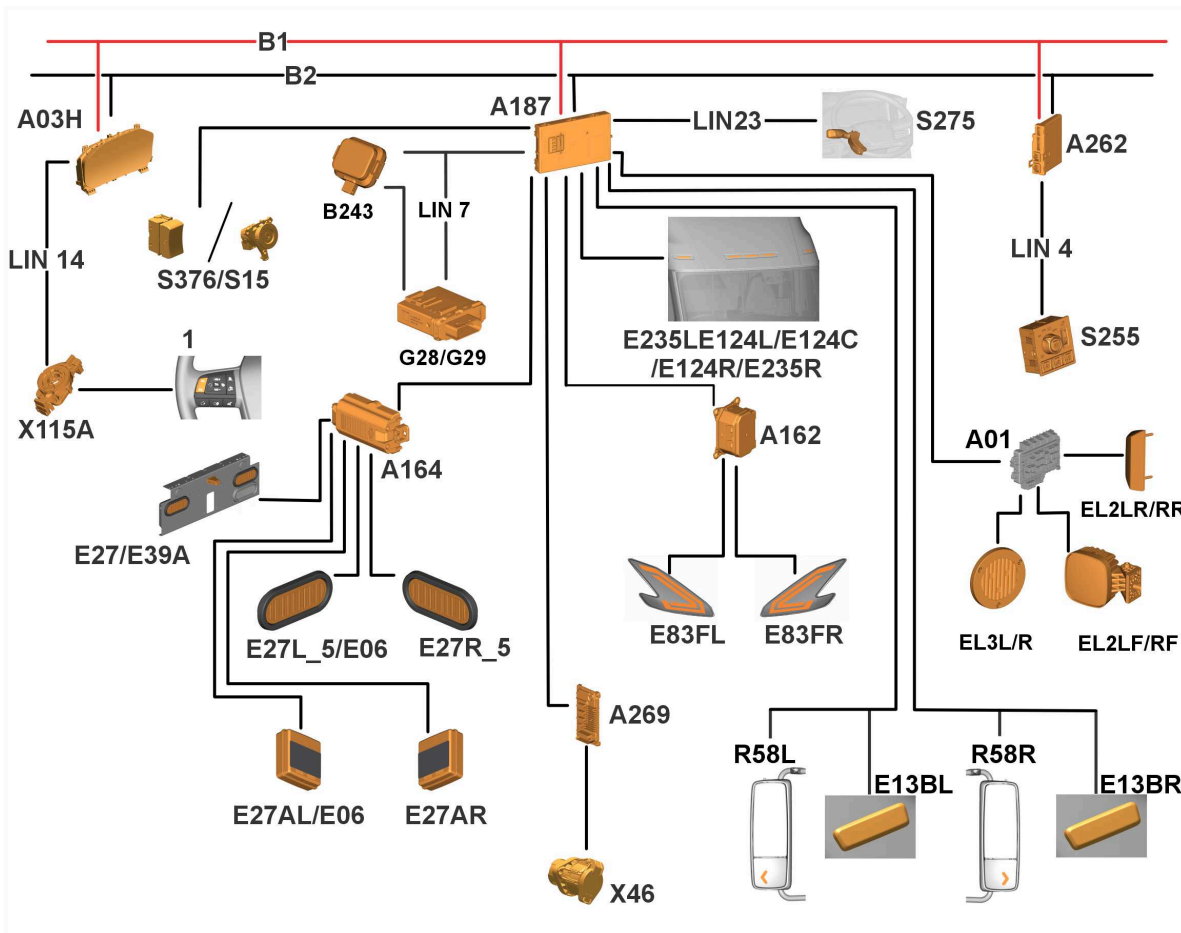

T3203388

Electrical ID	Description	Electrical ID	Description
B1	Backbone 1	E27R	Tail lamp (TL-LED) (right)
B2	Backbone 2	E39A	Number plate lamp
1	SWS	E83FL	Headlamp (left)
A01	FRC (Fuse and Relay Center)	E83FR	Headlamp (right)
A03H	Instrument cluster	EL2LR/RR	Work lamp (installed outer side of the deflector)
A162	FCIOM	EL3L/R	Work lamp (installed back side of the cab)
A164	RCIOM	G28/G29	PDC (Power Distribution Center)
A187	VMCU	LIN 14	LIN (Local Interconnect Network) 14
A262	SCIM	LIN 23	LIN 23
A269	TBIOM (Trailer Body Builder I/O Module)	LIN 4	LIN 4
B243	Rain sensor	LIN 7	LIN 7
E06	Reversing light	R58L	Direction indicator (mirror left)
E13BL	Direction indicator (repeater) lamp (left)	R58R	Direction indicator (mirror right)
E13BR	Direction indicator (repeater) lamp (right)	S255	ELCP
E235L/E124L/ E124C/E124R/ E235R	Roof marker (clearance) lamp	S275	Direction indicator stalk module
E27	Tail lamp (TL-LED3)	S376/S15	Passive start/stop or Key Ignition switch
E27AL	Tail lamp (TL-MULT2) (left)	X115A	Contact reel
E27AR	Tail lamp (TL-MULT2) (right)	X46	Trailer connector
E27L	Tail lamp (TL-LED) (left)		

Description

- 1 The combination high beam/low beam, turn signal switch transmits signals to the control unit.
- 2 The brake pressure contacts transmit a signal to the control unit.
- 3 The control unit supplies power to the tractor exterior lighting.
- 4 The control unit supplies power to the trailer exterior lighting when a trailer is connected.
- 5 The light control panel transmits signals to control the external lighting functions. Also, controls the dash and instrument cluster backlighting.
- 6 The central locking system transmits input signals to the control unit.
- 7 The reverse switch transmits an input signal to the control unit.
- 8 The control unit receives a signal from the steering wheel module for the headlamp and marker lamp interrupts.

Parameters for lighting control for body builders

Parameter code	Description	Min	Default value	Max	Unit
P1ZE0	Surround Light Command, enable True/False	-	True	-	-
P1ZE1	Door Puddle Light Command, enable True/False	-	True	-	-
P1B3V	Extra mainbeam rocker switch available True/False	-	True	-	-
P1GC8	Headlight Vertical Adjustment User Interface 0 = None 1 = Thumbwheel 2 = RockerSwitch	-	1	-	-
P1JXN	Direction Indicator Stalk Toggle Validation	-	100	-	ms
P1O8U	Conspicuity Lights Arbitration, Enable True/False	-	True	-	-
P1OP7	Side Direction Indicators, VMCU Control, Enable True/False	-	True	-	-
P1OZC	Position Light, Status Presentation, Enable True/False	-	True	-	-
P1NCN	Position Light Door Open Warning, Enable True/False	-	True	-	-
P1OIR	Exterior Lights, Enable True/False	-	True	-	-
P10P3	Trailer 12V Brake Light Circuit, Installed True/False	-	True	-	-
P1ZI6	Headlight and Position Lights, Automatic Activation, Wiper Condition, Enable True/False	-	True	-	-
P1ZGJ	Headlight Interrupt Switch, Installed True/False	-	True	-	-
P1YVE	Marker Interrupt Switch, Installed True/False	-	True	-	-
P1ZIM	Driver Notification, Dipped Beam Telltale, Enable True/False	-	True	-	-
P1B3U	Light Switch HMI Type 0 = Variant 1, Light control panel of freewheel type, with LED indication of light control mode 1 = Variant 2, Light control panel of freewheel type without LED indication of light control mode 2 = Variant 3, Light switch of fix position rotary switch 3 = Variant 4, Light switch of fix position rotary switch 4 = Variant 5, Light control panel of Freewheel type without LED indication of light control mode	-	3	-	-

P1B3W	Light Stalk HMI Type 0 = Light stalk of toggle type, without washer/wiper control 1 = Combined light stalk of toggle type and washer/wiper stalk 2 = Light stalk with stable positions for both dippedbeam and mainbeam position	-	1	-	-
P1PJA	Foglights, Activation Behaviour, Configuration 0 = Activation only allowed in light switch positions: Position Lights, Drive and Drive Plus 1 = Activation allowed in all light switch positions 2 = Activation only allowed in light switch position: Drive and Drive Plus	-	2	-	-
P11MV	Flash to Pass, Availability in Living Vehicle Mode, Enable True/False	-	True	-	-
P12SC	Hazard Lights, Activation By Hazard Switch in Vehicle Mode Parked, Enable True/False	-	True	-	-
P10PZ	Body Builder 12 V Reverse Light Circuit, Installed True/False	-	False	-	-
P10P0	Body Builder 12V Reverse Light Circuit, Open Circuit Detection, Enable True/False	-	True	-	-
P10YM	Front Lights, Adaptive System, Type 0 = Glarefree Headlamps 1 = Auto High beam On/Off	-	1	-	-
P1ZEC	Daytime Running Lights, Override, Enable True/False	-	True	-	-
P1O51	Automatically Controlled Dipped Beam in DrivePlus, Enable True/False	-	True	-	-
P1DES	Automatically Controlled Dipped Beam, Enable True/False	-	True	-	-
P1DDP	Static Cornering Lights, Function True/False	-	True	-	-
P1F01	Cab Body Working Lamps Open Circuit Diagnostics, Enable	-	Enabled	-	-
P1F02	Side Reverse Working Lights Open Circuit Diagnostics, Enable	-	Enabled	-	-
P1DD4	Main Switch, Hazard Indication, Enable True/False	-	True	-	-
P1EIC	Approach Lights, Enable True/False	-	True	-	-
P13UU	Daytime Running Lights, Inhibit Override, Vehicle Distance Condition, Configuration	-	100	-	m
P1F02	Side Reverse Working Lights Open Circuit Diagnostics, Enable	-	Enabled	-	
P1ZED	Daytime Running Lights, Inhibit Override, Time, Threshold	1	1	255	min

P1ZEF	Daytime Running Lights, Inhibit Override Conditions, Configuration 0 = Vehicle speed or time condition 1 = Vehicle speed with time validation	-	1	-	-
P1NAQ	Rear Fog Light Indication, Enable True/False	-	True	-	-
P1PJB	Foglights, User Input Failure Handling, Configuration 0 = Remain with previous valid foglight request 1 = Assume foglights are not requested	-	1	-	-
P1DD9	Fog Light Button Panel, Type	-		-	-
P1NAP	Front Fog Light Indication, Enable True/False	-	True	-	-
P1B30	Front Fog Lights, Function True/False	-	True	-	-
P1XT0	Cab Max Mode, Command, Enable True/False	-	True	-	-
P1XT1	Cab Max Light Circuit, Enable True/False	-	True	-	-
P1X2X	Cab Lower Ambient Mode, Command, Enable True/False	-	True	-	-
P1X2Y	Cab Lower Ambient Light, Circuit, Enable True/False	-	True	-	-
P10K1	Cab Max Light Activation, Engine Turned Off Condition, Enable True/False	-	True	-	-
P10K2	Cab Max Light, Any Door Opened Condition, Enable True/False	-	True	-	-
P10K3	Cab Lower Ambient Light, Any Door Opened Condition, Enable True/False	-	True	-	-
P1X2U	Cab Upper Ambient Mode, Command, Enable True/False	-	True	-	-
P1X2V	Cab Upper Ambient Light, Circuit, Enable True/False	-	True	-	-
P1Y9A	Sleeper Upper Ambient Mode, Command, Enable True/False	-	True	-	-
P1DDH	Interior Lights, Dimming Intensity	-	6	-	-
P1NHR	IL Ramp Feature, Enable TRUE = Ramping feature is accessible FALSE = Ramping feature is not accessible	-	True	-	-
P1DCY	PWM period used for interior light dimming control of bulb lights Only 2 possible values allowed: 4167 microseconds (corresponds to 240 Hz) 8333 microseconds (corresponds to 120 Hz)	-	4167	-	µs
P1DCP	Active Battery Management of interior lights Enabled True/False	-	False	-	-

P1DCX	Max Mode Command, Enable TRUE = Max Mode is Enabled FALSE = Max Mode is Disabled	-	False	-	-
P1DC9	Activate Max Light Circuit When Engine Is Turned Off TRUE = The max light circuit will be set to 100% intensity when engine is turned off FALSE = The max light circuit will not be lit when engine is turned off	-	False	-	-
P1DDA	Activating Max Light Circuit when Any Door is Opened TRUE = The max light circuit will be ramped up when the open door condition is fulfilled FALSE = The opened door condition will not lit the max light circuit	-	False	-	-
P1DDD	Activating Resting Light Circuit When Max Mode Is Commanded TRUE = The resting light circuit will be ramped up when the max mode command is commanded. FALSE = The max mode command will not lit the resting light circuit	-	False	-	-
P1DDF	Deactivating night light circuit when engine is turned off When this parameter is set to TRUE the night light circuit will be ramped down when engine is turned off When this parameter is set to FALSE the engine turned off will not unlit the resting light circuit.	-	False	-	-
P1ESB	Enable Maximum Max light Intensity When Max Mode Is Requested TRUE= Maximum Max light intensity is applied in Max light mode FALSE = Maximum Max light intensity is not applied in Max light mode	-	False	-	-
P1G5A	Door Warning Light Activation Enabled Enables or disables door warning light activation True = DoorWarningLight will be enabled False = DoorWarningLight will be disabled	-	False	-	-
P1G5B	Chassie Instep Light Activation Enabled Enables or disables the chassie instep light activation True = Chassie Instep Light enabled False = Chassiel nstep Light disabled	-	False	-	-
P1NFF	Max Light, Circuit 2, Enable TRUE = Max Light Circuit 2 Enabled FALSE = Max Light Circuit 2 Disabled	-	False	-	-
P1NFG	Resting Light, Circuit 2, Enable TRUE = Resting Light Circuit 2 Enabled FALSE = Resting Light Circuit 2 Disabled	-	False	-	-
P1NHO	Max Light, Circuit 1, Enable TRUE = Max Light Circuit 1 Enabled FALSE = Max Light Circuit 1 Disabled	-	False	-	-
P1NHP	Resting Light, Circuit 1, Enable TRUE = Resting Light Circuit 1 Enabled FALSE = Resting Light Circuit 1 Disabled	-	False	-	-

P1NHQ	Night Light, Circuit, Enable TRUE = Night Light Circuit Enabled FALSE = Night Light Circuit Disabled	-	False	-	-
P1Y58	Sleeper Max Mode, Command, Enable True/False	-	True	-	-
P1Y8W	Sleeper Lower Ambient Mode, Command, Enable True/False	-	True	-	-
P1Y57	Sleeper Max Light, VMCU Control, Enable True/False	-	True	-	-
P1Y8V	Sleeper Lower Ambient Light, VMCU Control, Enable True/False	-	True	-	-
P1DCQ	Dimming Mode for Max Light Circuit Controls the dimming mode selected for the max light circuit. Dimming can be: 0 = Disabled. Dimming requests will always be disregarded 1 = Enabled. Dimming requests will be handled for this circuit 2 = Enabled when doors closed. Not implemented. Do not use.	-	Disabled	-	-
P1DCR	Dimming mode for resting light circuit Controls the dimming mode selected for the resting light circuit. Dimming can be: 0 = Disabled. Dimming requests will always be disregarded 1 = Enabled. Dimming requests will be handled for this circuit 2 = Enabled when doors closed. Dimming requests will be handled only when doors is closed for this circuit	-	Disabled	-	-
P1DCS	Dimming mode for night light circuit Controls the dimming mode selected for the night light circuit. Dimming can be: 0 = Disabled. Dimming requests will always be disregarded 1 = Enabled. Dimming requests will be handled for this circuit 2 = Enabled when doors closed. Dimming requests will be handled only when doors is closed for this circuit	-	Disabled	-	-
P1DCV	Resting Mode Command, Enable TRUE = Resting Mode is Enabled FALSE = Resting Mode is Disabled	-	False	-	-
P1DCW	Night Mode Command, Enable TRUE = Night Mode is Enabled FALSE = Night Mode is Disabled	-	False	-	-
P1DDB	Activating resting light circuit when engine is turned off TRUE = The resting light circuit will be ramped up when engine is turned off FALSE = The engine turned off will not lit the resting light circuit	-	False	-	-
P1DDC	Activating Resting Light Circuit when Any Door is Opened TRUE = The resting light circuit will be ramped up when the open door condition is fulfilled FALSE = The opened door condition will not lit the resting light circuit	-	False	-	-

P1DDE	Selects IL Core Feature For VT Or RT/UD TRUE = Interior Lights features for other (RT/UD) is selected FALSE = Interior Lights features for Volvo is selected	-	False	-	-
P1ESC	Maximum Night Light Intensity, Enable TRUE = Maximum Night light intensity is applied in Night light mode FALSE = Maximum Night light intensity is not applied in Night light mode	-	False	-	-
P1Y58	Sleeper Max Mode, Command, Enable. True/False	-	True	-	-
P1Y8W	Sleeper Lower Ambient Mode, Command, Enable. True/False	-	True	-	-
P10SI	Body Builder 12V Position Lights, Installed. True/False	-	False	-	-
P10XJ	Direction Indicator Circuit, Installed. True/False	-	False	-	-
P10ZB	Brake Light Circuit, Installed. True/False	-	False	-	-
P106M	Brake Light and Direction Indicator Combined. True/False	-	False	-	-

Transmission Electronic Control Unit

Several electronically-controlled transmissions are available, depending on engine and vehicle type:

- Volvo I-Shift

This transmission uses a Transmission Electronic Control Unit (TECU) which interfaces to the vehicle system and vehicle databases. All of the transmissions use the ISO databus to direct the engine into certain operating modes, either to facilitate smoother shifts, synchronize engine speed to driveline speed, or allow/disallow engine braking.

The TECU are located as follows:

- Volvo I-Shift - TECU is located on the top of the transmission.

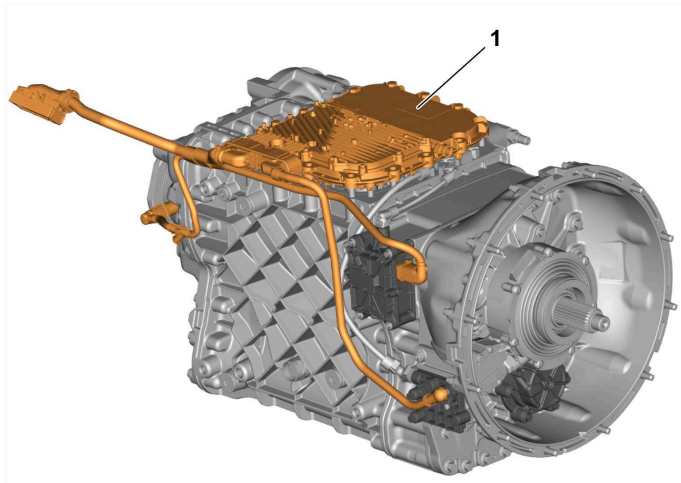

T3204718

1. TECU (Transmission Electronic Control Unit)

The transmission electronics and their interaction with the rest of the vehicle systems is a very important interface, one which affects many aspects of the vehicle operation and safety.

Note: Volvo Trucks North America does not recommend any circuit modifications, alterations, or additions to any of the transmission electronics, including sensors and actuators used by the transmissions.

CAUTION

DO NOT interface to, modify, or alter any of the sensors or circuits used by the Transmission TECU.

Refer to the appropriate service manual for all service information. Refer to the VNL schematics for details on how each transmission TECU interfaces to the vehicle. Refer to the appropriate transmission manufacturers literature for all service procedures and details on the transmission TECU.

Refer to “VNL Wiring Topology”, page 18 for a detailed layout of the data link backbone.

V O L V O

Volvo Trucks North America

<http://www.volvotrucks.com>