



## Oils and Filters

This information provides specifications for Oil and Filters applications in Volvo vehicles.

**Note:** We have attempted to cover as much information as possible. However, this information does not cover all the unique variations that a vehicle chassis may present. Note that illustrations are typical but may not reflect all the variations of assembly.

All data provided is based on information that was current at the time of release. However, **this information is subject to change without notice.**

Note that no part of this information may be reproduced, stored or transmitted by any means without the express written permission of Volvo Trucks North America.

### Contents:

- “Standardized Design Solutions/Maintenance”, page 2
- “Oil and Filters, Engine Transmission, Axle and Fuel Tank”, page 2
- “Fuel”, page 7
- “Coolant Requirements”, page 8

# Standardized Design Solutions/Maintenance

## Oil and Filters, Engine Transmission, Axle and Fuel Tank

### D13 Engine

Engine	Oil Capacity in quarts
D13	33 (31 L)

### D13 Engine (Vehicle with two full flow oil filters)

All units in quarts	Total volume of oil in filter	Oil pan volume	Oil change volume
Steel oil pan	4.75 (4.5 L)	33 (31 L)	37 (35 L)
Composite oil pan	4.75 (4.5 L)	33 (31 L)	37 (35 L)
Aluminum oil pan	5.3 (5 L)	34 (32 L)	38 (36 L)

## Approved Oils

For a complete list of Approved Oils used in Volvo Engines, transmissions and other components, refer to [http://www.volvotrucks.com/SiteCollectionDocuments/VTNA\\_Tree/ILF/parts\\_and\\_service/service/approved\\_oils/PV776-89091965.pdf](http://www.volvotrucks.com/SiteCollectionDocuments/VTNA_Tree/ILF/parts_and_service/service/approved_oils/PV776-89091965.pdf)

# D13 Engine Oil Type/Quality

EO-O Premium Plus or VDS-5 (Volvo Drain Specification-5) diesel engine oil is mandatory for use in all US 2010 emission-compliant VOLVO engines. Chassis equipped with a US 2010 emission-compliant engine, which can be identified by the presence of an aftertreatment Selective Catalytic Reduction (SCR) system, also require the use of ultra low sulfur diesel (ULSD) fuel. EO-O Premium Plus oils exceed the new American Petroleum Institute (API) service category CJ-4.

Engines meeting the 2010 and later emissions requirements are designed with exhaust aftertreatment systems requiring an oil that meets Volvo EO-O Premium Plus quality standards for model year 2010 and later Volvo engines. The Volvo EO-O Premium Plus quality standard is based on the API CJ-4 engine oil specification, but has additional performance requirements essential to adequately protect the Volvo engines at the drain intervals specified. Pre-2010 engines also work better with the recommended engine oils. They are not required, but are strongly recommended.

Model Year	Recommended VDS Specification/ API standard	Minimum VDS Specification/ API standard
2021 and Newer	VDS-5.0/FA-4	VDS-4.5/CK-4

**Note:** VDS corresponds to API standard: VDS-4.5/CK-4, VDS-5.0/FA-4.

## Viscosity Diagram, Engine

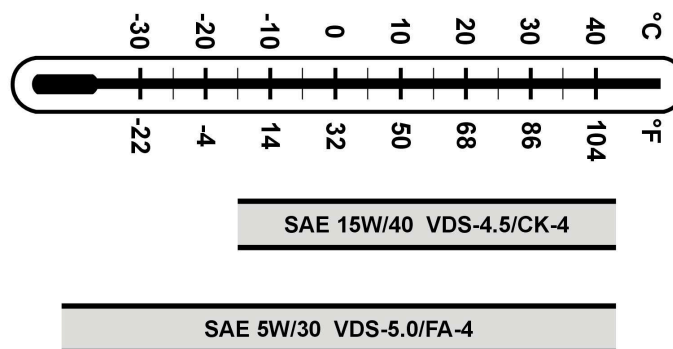

T1202619

**Note:** Based on cold starting temperature.



### CAUTION

Extra oil additives must never be added to any engine oil used.

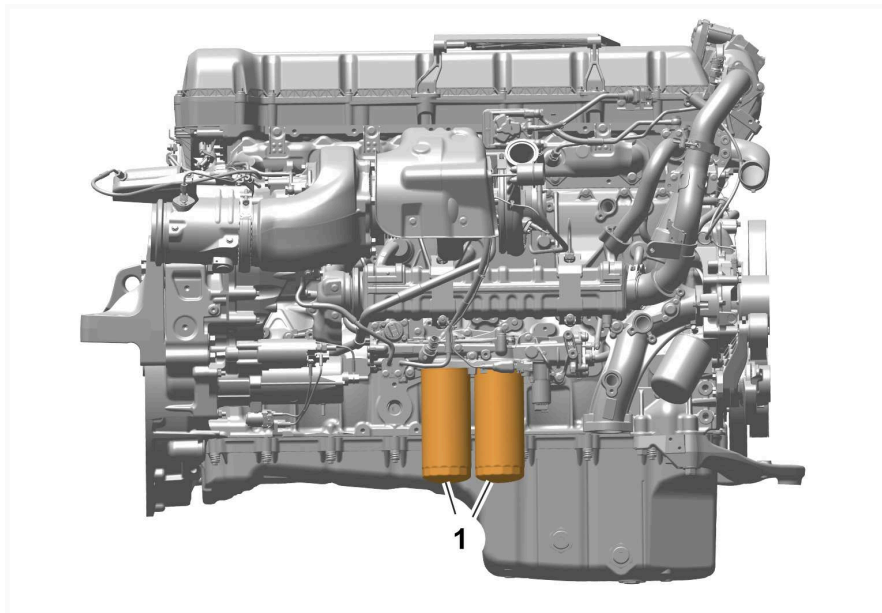

T2196748

1 — Oil Filter (D13 Engine)

**Note:** The oil filter housing consists of two full flow filters. From the model year 2020 D13 engines with VGT (Variable Geometry Turbocharger).

## Rear Axle Oil

Refer to vendor information for rear axle lube type and capacity”.

# Check I-Shift Transmission Oil Level

Check the I-Shift transmission oil level at each service interval. To do so, park the vehicle on a level surface and check the transmission oil level through the sight glass on the right side of the transmission. Add Volvo-approved synthetic transmission oil as needed. Note that the drain plug indicates the type of oil used in the transmission.

Silver Drain Plug	Spirax S6 AXME I-Shift Heavy Duty
Brass Drain Plug	75W-90 I-Shift Standard

Recommended SAE Grades for I-Shift Transmissions	
Volvo Synthetic Transmission Oil	
75W-90, Spirax S6 AXME	

## Volvo Oil Types and Part Numbers

Oil Grade	Part Number and Alternative
Spirax S6 GXME Ultra 75W-90	22692022, long life transmission and axle oil

### Sight glass for checking transmission oil level.

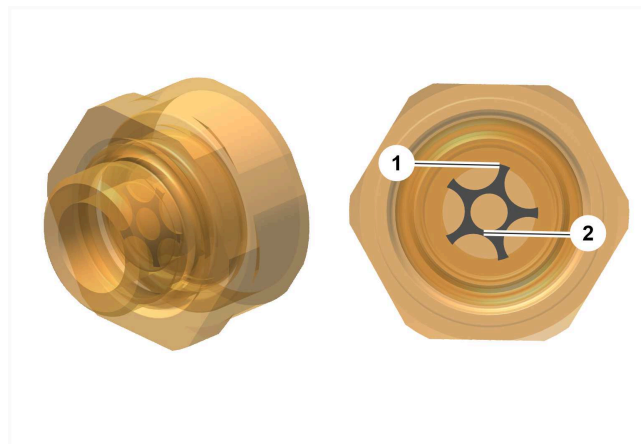
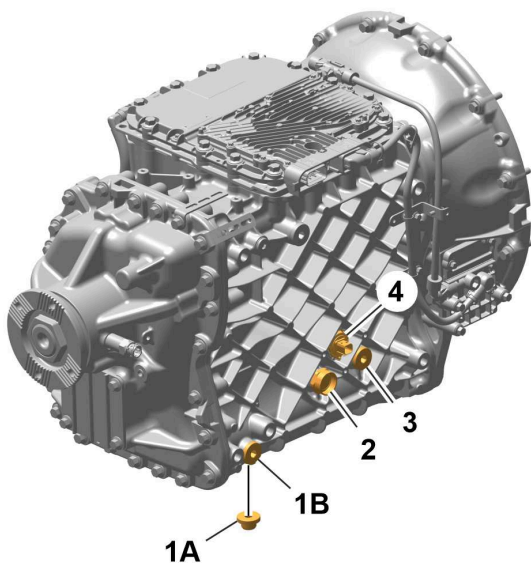

T2196750

T2196749

- 1A — Drain Plug.
- 1B — Drain Port.
- 2 — Sight Glass.
- 3 — Fill Plug and Oil level.
- 4 — Oil level sensor.

- 1 — Max oil level.
- 2 — Min oil level.

# I-Shift Lubrication Capacity

Transmission	Oil Type	Capacity Including Cooler
<b>I-Shift – Volvo</b>		
ATO 12	Refer to the approved oils list (SB 175–61)	<b>17.9 quarts</b>
ATO 13/ATO 14	Refer to the approved oils list (SB 175–61)	<b>20.5 quarts</b>

## Fuel Ventilation

### *Fuel Tank Ventilation Filter*

Some vehicles are equipped with a fuel tank ventilation filter. This filter must accompany the fuel tank if the tank is relocated.

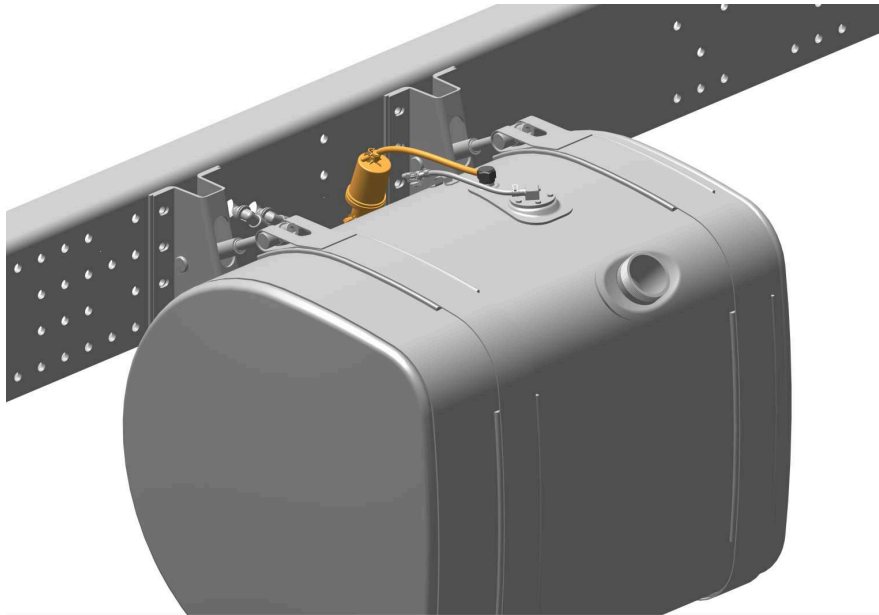

T2196751

Frame Rail-Mounted Filter

# Fuel



## CAUTION

Diesel engines for US 2010-current vehicles are designed to operate only with ultra low sulfur diesel (ULSD) fuel. Use of fuel other than ULSD reduces the efficiency and durability of the engine, permanently damage the advanced emission control systems, reduce fuel economy and possibly prevent the engine from running at all. Manufacturer's warranties are likely to be rendered void by usage of improper or incorrect fuel, and usage of fuels other than ULSD fuel in diesel-powered vehicles is illegal and punishable with civil penalties. Use of fuel additives to compensate for the lower sulfur content is NOT recommended by Volvo Trucks North America.

Fuel sold for use in diesel-powered engines for US 2010-current vehicles may only contain a maximum sulfur content of 0.0015% by weight. This was done to reduce particle emissions in the exhaust.

# Coolant Requirements

**Note:** DO NOT mix different coolant products, such as regular antifreeze and extended life antifreeze, etc.

**Note:** Refer to the decal on the coolant expansion tank for the factory fill coolant type.

## VCS2 Coolant

**Effective August 24th, 2023**, Volvo Trucks has changed from Genuine Extended Life NF Premixed 50/50 Coolant to Genuine VCS2 Coolant. The Genuine VCS2 Coolant offers improved coolant system performance and lower environmental impact.

### Product Details:

- Color: Orange
- Advanced Phosphate Organic Acid Technology (POAT)
- 2EHA & Nitrite Free Formula
- Cooling System Protection: 1.5 million mile/10 Years/36,000 hours
- Eliminates the need for Extenders and Supplemental Coolant Additives (SCAs)
- Superior Water Pump Protection: Perfect 10 water pump test rating
- Outstanding protection against corrosion, cavitation, scale, and deposits.

### Recommendations for Coolant Change

The systems in contact with VCS must be drained/purged and then completely rinsed or flushed with demineralized/deionized water before changing from VCS to VCS-2 coolant.

Coolant must be visually checked before using for the first time. The coolant color must be orange at the outlets.

Use the following antifreeze protection charts to determine the percentage of antifreeze needed to achieve specific protection levels for various coolant systems.

### Ethylene-Glycol Protection Chart

Ethylene-Glycol	Ambient Air Temperature
40%	-24°C (-12°F)
50%	-37°C (-34°F)
60%	-52°C (-62°F)

### Propylene-Glycol Protection Chart

Propylene-Glycol	Ambient Air Temperature
40%	-21°C (-6°F)
50%	-33°C (-27°F)
60%	-49°C (-56°F)

A well functioning and maintained cooling system is as important to the engine as performing regular oil changes or using good fuel. To get the best result, use quality products and service the system at the correct intervals. Please read this section carefully.

Keep the radiator (including charge air cooler) and the frontal area free from bugs, dirt, leaves, etc.

Check the coolant level in the tank regularly. Fill the tank as necessary with the correct coolant.

Inspection of the whole cooling system is important. Check for swollen or deteriorated heater and radiator hoses, loose hose clamps and connections, and coolant leaks.



## **DANGER**

DO NOT work near the fan with the engine running. The engine fan can engage at any time without warning. Anyone near the fan when it turns on could be seriously injured. Before turning on the ignition, be sure that no one is near the fan.



## **CAUTION**

Never add coolant to a hot or overheated engine. Engine damage can result. Allow the engine to cool first

**V O L V O**

**Volvo Trucks North America**

<http://www.volvotrucks.com>