



## Body Builder, General Guidelines and Certification VNR Electric

### Introduction

The information in this document was developed to assist our customers throughout the body planning and installation process. This information will assist with the required specifications and guidelines for completion for your specific applications.

The information in this document does not include each and every unique situation that you may encounter when working on Volvo vehicles. Volvo Trucks North America cannot possibly know, evaluate, or advise someone on all the types of work that can be done on a Volvo vehicle and all the appropriate ways to do such work. This includes all of the possible consequences of performing such work in a certain manner. Therefore, any situations or methods of working on a Volvo vehicle that are not addressed in this document are not necessarily approved by Volvo Trucks North America.

In the event that you require additional assistance, please contact Volvo Body Builder Support at 877-770-7575.

Unless otherwise stated, following the recommendations listed in this document does not automatically guarantee compliance with applicable government regulations. Compliance with applicable government regulations is your responsibility as the party making the additions/modifications. Please be advised that the Volvo Trucks North America vehicle warranty does not apply to any Volvo vehicle that has been modified in any way, which in Volvo's judgment might affect the vehicles stability or reliability. The information, specifications, and illustrations in this document are based on information that was current at the time of publication. Please note that illustrations are typical and may not reflect the exact arrangement of every component installed on a specific vehicle.

All data provided is based on information that was current at time of release. However, this information is subject to change without notice.

Please note that no part of this information may be reproduced, stored, or transmitted by any means without the express written permission of Volvo Trucks North America.

## **Contents:**

### **“General”, page 4**

“Introduction”, page 4

“General warnings”, page 4

“Abbreviations”, page 5

“General description”, page 7

### **“Safety”, page 12**

“Safety working rules”, page 12

“Electrical safety”, page 12

“Chassis switch”, page 15

“Fire safety”, page 18

### **“Chassis”, page 22**

“Welding”, page 22

“Drilling”, page 23

“Painting”, page 23

“Towing”, page 24

“Washing”, page 24

“Body start dimensions”, page 27

“Body/Subframe Mounting”, page 28

“Body Dimensions”, page 28

### **“BEV cooling systems”, page 31**

“Passive cooling system for CESS-P”, page 31

“Active and Passive cooling system for CESS-A”, page 36

### **“Electrical/Electronic information”, page 44**

“Battery Charging”, page 44

“Parking recommendation”, page 53

“Body builder connector (X194)”, page 55

“Vehicle Accessory Connector (RP1226)”, page 57

“Fuse and relay box”, page 60

“24 V Power Supply”, page 80

“Ground locations”, page 83

**“Mechanical ePTO”, page 87**

**“Routing and Clamping”, page 94**

“General”, page 94

“Routing”, page 95

“Clamping”, page 95

**“Instrument Panel”, page 97**

“Instrument Cluster”, page 99

“Dashboard switches”, page 108

“Steering wheel mounted controls”, page 116

“Stalk switch controls”, page 117

**“Suspension”, page 119**

**“Lighting”, page 129**

**“ECU Functions and Parameter Programming ”, page 130**

“Road speed limit”, page 132

“Cruise Control”, page 133

“Auto Neutral”, page 136

“ATVSA Enable/Disable”, page 136

“TVS (Traction Voltage System) Inhibition”, page 137

“Vehicle Electronic Control Unit (VECU)”, page 138

“Description of VECU Signals (VECU 4)”, page 138

**“Data Link”, page 142**

**“Multiplexing Body Builder DL5 J1939 CAN ”, page 150**

# BEV (Battery-Electric Vehicle)

## General

### Introduction

This document includes the information that is specific to the truck model VNR ELECTRIC. For all other common information related to VNR truck, refer to the relevant VOLVO Body Builder Manual.

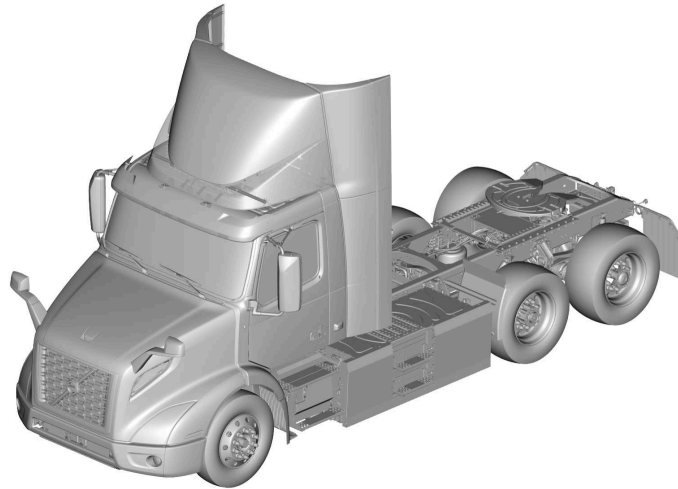

T0164946

Overview of battery-electric vehicle

## General warnings



### DANGER

#### Risk of electrical discharge

#### Traction voltage system, 600 V (nominal value)

Can cause dangerous electric shocks, arcing or burns, which can result in serious personal injury or death.

Service and installation must be carried out by qualified personnel. Always use correct personal protection equipment when working on the vehicle.

**Note:** Accessory electrical circuits should always be fused. Where possible, use the designated spare fuses or circuit breakers that are already supplied. Never overload the circuit beyond the rated amperage of the fuse or circuit breaker. Inductive loads, such as motors, light bulbs, and relays, cause higher current draw (surge current) in electrical circuits during initial start-up or turn-on. These circuits may require slow-blow fuses or higher-rated fuses or circuit breakers. The installation of add-on circuits for the body installation may interfere with the proper operation of other vehicle electrical components. The body installer is responsible for ensuring the continued proper operation of all electrical systems on the vehicle concerning conducted or radiated signals from the installation.

The components that contain traction voltage are marked with the warning decal.



T3167712

## Abbreviations

ABS	Anti-lock Braking System
ATVSA	Automatic Traction Voltage System Activation
AC	Alternating Current
BMU	Battery Management Unit (in the ESS)
BTMS	Battery Temperature management system
CAN	Control Area Network
CCS	Combined Charging System
CSU	Charging Switch Unit
Commissioning	Reversing the electrical safety process in order to return the vehicle to service.
Decommissioning	Making the vehicle and personnel electrically safe before carrying out an operation.
DC	Direct current
ECC/MCC	Electronic Climate Control/ Manual Climate Control
ECS	Electronically Controlled Suspension
EM	Electric Motor
EMC	Electromagnetic Compatibility
EMI	Electro-magnetic interference
EMD	Electric Motor Drive
ESS	Energy Storage System
EV	Electric Vehicle
EVCN	Electromobility Vehicle Control Module
EVAC	Electric Vehicle Air Compressor
ePTO	electromobility Power Take-Off
FAS	Front Active Steering
FAS-GW	Front Active Steering-Gateway
FLC	Forward Looking Camera
FLR	Forward Looking Radar
FRC	Fuse and Relay Center

HVIL	Hazardous Voltage Interlock Loop
LCM	Light Control Module
LCS	Lane Change System
LECM	Living Environment Control Module
LIN	Local Interconnect Network
LHS	Left-hand side
OBD	On-board Diagnostic
OCEPS	On-board Charger and Electric Power Supply
PCM	Powertrain Control Module
PE	Protective Earth
RHS	Right-hand side
RMS	Root Mean Square
SACU	Side Airbag Control Unit (RollTek)
SAE	Society of Automotive Engineering
SDP	Safety Direct Processor
SEM	Services and Entertainment Module
SOC	State of charge
SRS	Supplementary Restraint System
TGW	Telematics Gateway
TPMS	Tire Pressure Monitoring System
TVJB	Traction Voltage Junction Box
TVMU	Traction Voltage Monitoring Unit
TVS	Traction Voltage System
VECU	Vehicle Electronic Control Unit
VIN	Vehicle Identification Number

# General description

BEV (Battery-Electric Vehicle) Layout

## VNR 42T

Model	Axle arrangement	Wheelbase	Vehicle maximum load capacity (including trailer)	Number of traction batteries	ESS Total Energy Capacity
VNRE42T	4x2	4300 mm (169 inches)	36 t (72,000 lb)	4	GEN2 – 265 kWh GEN3 – 375 kWh
				6	GEN3 – 565 kWh

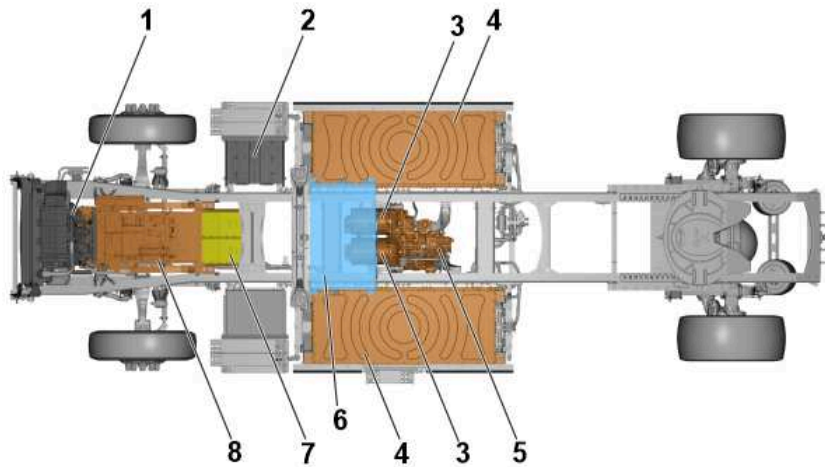

T0182372

- 1 Electric cooling system
- 2 24 V system batteries
- 3 EM (Electric Motor)
- 4 Traction batteries
- 5 Transmission
- 6 BTMS (Battery Temperature management system)
- 7 EMD (Electric Motor Drive)
- 8 MPB (Modular Power Box).

VNR 62T/64T

Model	Axle arrangement	Wheelbase	Vehicle maximum load capacity (including trailer)	Number of traction batteries	ESS Total Energy Capacity
VNRE62T	6x2	5600 mm (220 inches)	41 t (82,000 lb)	4	GEN2 – 265 kwh GEN3 – 375 kwh
				6	GEN3 – 565 kwh
VNRE64T	6x4	4450 mm (175 inches)	41 t (82,000 lb)	4	GEN2 – 265 kwh GEN3 – 375 kwh
				6	GEN3 – 565 kwh

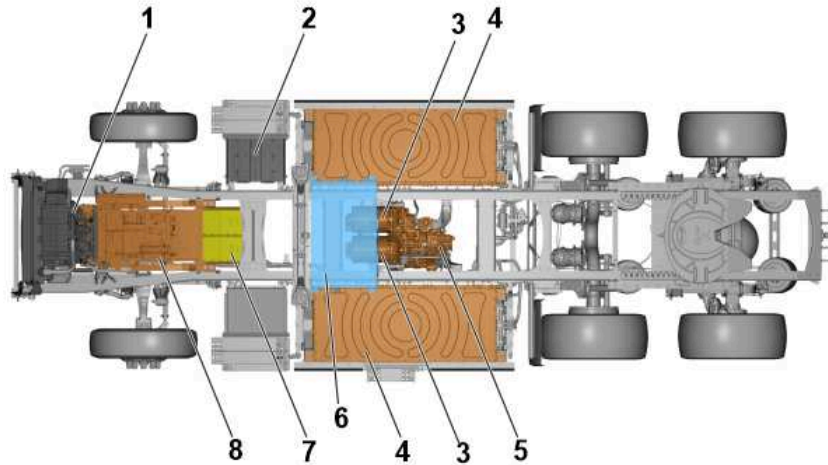

T0182373

- 1 Electric cooling system
- 2 24 V system batteries
- 3 EM (Electric Motor)
- 4 Traction batteries
- 5 Transmission
- 6 BTMS (Battery Temperature management system)
- 7 EMD (Electric motor Drive)
- 8 MPB (Modular Power Box)

VNR 42R

Model	Axle arrangement	Wheelbase	Vehicle maximum load capacity	Number of traction batteries	ESS Total Energy Capacity
VNRE42R	4x2	Totally 45 wheelbases are applicable for 4x2 rigid. Starting from 4250 mm (167 inches) to 6600 mm (260 inches) in the interval of 2 inches.	16.5 t (33,000 lb)	4	GEN2 – 265 kwh GEN3 – 375 kwh

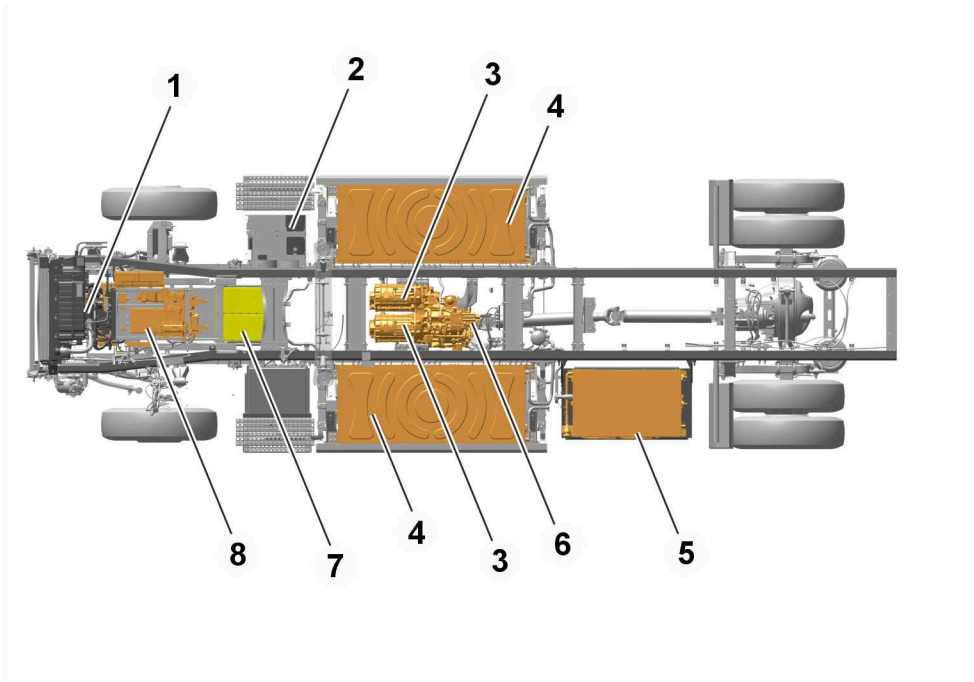

T2212482

- 1 Electric cooling system
- 2 24 V system batteries
- 3 EM (Electric Motor)
- 4 Traction batteries
- 5 BTMS (Battery Temperature management system)
- 6 Transmission
- 7 EMD (Electric Motor Drive)
- 8 MPB (Modular Power Box)

VNR 62R/64R

Model	Axle arrangement	Wheelbase	Vehicle maximum load capacity (including trailer)	Number of traction batteries	ESS Total Energy Capacity
VNRE64R	6x4	Totally 39 wheelbases are applicable for 6x4 rigid. Starting from 4250 mm (167 inches) to 6150 mm (242 inches) in the interval of 50 mm (2 inches).	41 t (82,000 lb)	4	GEN2 – 265 kwh GEN3 – 375 kwh

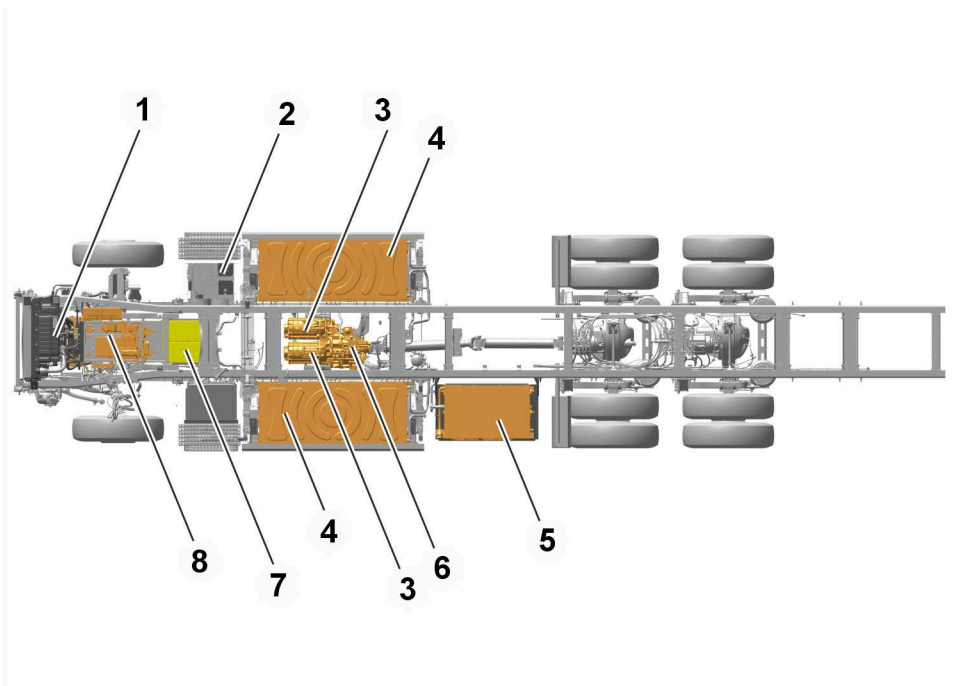

T2212483

- 1 Electric cooling system
- 2 24 V system batteries
- 3 EM (Electric Motor)
- 4 Traction batteries
- 5 BTMS (Battery Temperature management system)
- 6 Transmission
- 7 EMD (Electric Motor Drive)
- 8 MPB (Modular Power Box)





## The traction voltage system

The traction voltage system (600 V), which is used to drive the vehicle contains hazardous voltage. To avoid the risk of electric shock or hazardous electrical burn, follow the instructions and safety precautions.

The electric driveline includes the electric motors and the transmission that are located between the frame rails and to the rear of the cab. The traction batteries are mounted between the vehicle chassis and the side protectors, and to the back of cab (optional). In these two areas, and also in the area underneath the cab, there are numerous electrical components (600 V), cables and connectors.

### **DANGER**

#### **Risk of electrical discharge**

Incorrect handling of the traction voltage system (>60 V DC (Direct Current)) can cause electric shocks and arcs resulting in serious burns or death.

“Do not repair, dismantle, remove or replace any component, cable, connector, cover or electrical traction protection. Any operation must only be carried out by personnel with adequate training according to **Safety regulations, electric vehicles.**”

Decommissioning and commissioning must only be carried out by personnel with adequate certification according to **Safety regulations, electric vehicles.**

Always use Personal Protective Equipment (PPE) as described in the **Safety regulations, electric vehicles.**

Always use appropriate measuring tools as described in the **Safety regulations, electric vehicles.**

### **CAUTION**

It is strictly forbidden to connect to the 600 V circuit.

### **CAUTION**

It is strictly forbidden to move any of the 600 V elements.

### **DANGER**

#### **Risk of electrical discharge**

Do not touch or go near any damaged traction voltage components, cables or connectors.

### **WARNING**

#### **Risk of serious personal injury**

The fans for cooling the traction batteries and other components in the traction voltage system can be energized automatically without any warning, even when the key is removed from the starter switch and the truck is parked.

### **WARNING**

#### **Risk of component damage**

Decommissioning incorrectly can result in substantial damage, requiring costly repairs. For this reason, the decommissioning must be performed by a personnel who have received the necessary training (obtained at the Volvo Trucks dealer or market company).

**Note:** The **Safety regulations, electric vehicles** information can be found in IMPACT, under function group 30 and info-type “Repair”.

**⚠ DANGER**

**Risk of electrical discharge**

Do not remove any covers, hatches or similar components that are marked with the warning decal.

**TVS cables and connectors:**

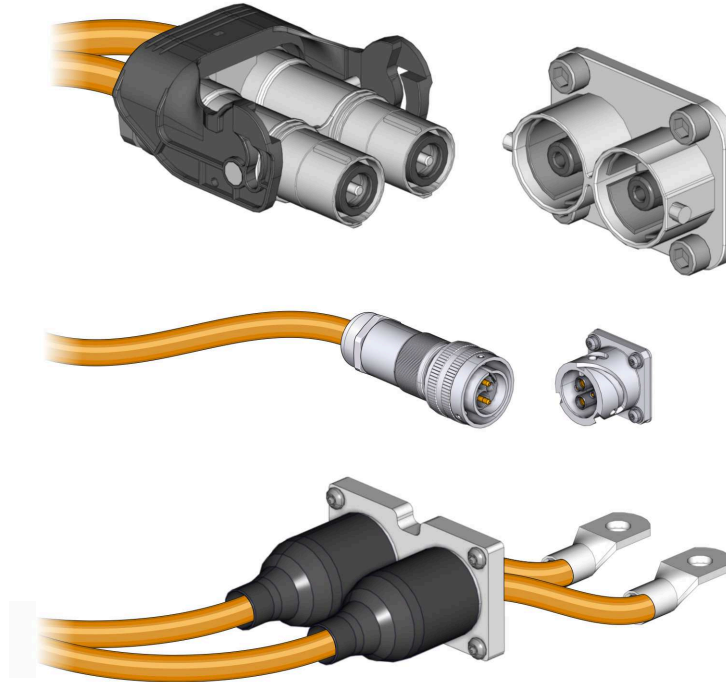

T3169719

**Note:** All orange colored cables in the vehicle are traction voltage (600 V) cables.

**24 V system**

**⚠ CAUTION**

Turn the chassis switch to off position before performing any work on the 24 V system batteries (two 12 V batteries connected in series).

For any other work related to 24 V and 12 V systems, normal regulation and recommendations apply. Contact Volvo Trucks dealer for more information.

**Note:** It is recommended not to perform any additional installation on the 24 V system.

# Chassis switch

600 V can be distributed based on few possibilities in the vehicle, for example:

- Key in + after START position, then motor starts
- During traction battery recharging with an off-board charger
- When the temperature of the traction batteries is maintained

A switch is installed in the chassis to stop the possible 600 V distributions in the vehicle (through a controlled shutdown sequence).



## CAUTION

To perform any work in the commissioned vehicle, turn the chassis switch to the off position.



## CAUTION

Turning the chassis switch to the off position, does not mean that the vehicle safety decommissioning procedure has been carried out.



## CAUTION

Decommissioning and commissioning must only be carried out by personnel with adequate certification.

## Position of chassis switch



## DANGER

If the chassis switch is in the On position, the ATVSA (Automatic Traction Voltage System Activation) function can be automatically activated without any special action being taken and irrespective of the position of the starter key or of the connection to the offboard charger. There are various reasons why the 600 V circuit may be reactivated (to maintain charge in the 24 V system batteries, to maintain temperature of traction batteries etc.)



## CAUTION

The voltage system of the electrical traction network is not energized when the chassis switch is in the Off position.

The chassis switch is located on the left-hand side of the truck next to the vehicle offboard charging interface and near to the footsteps.

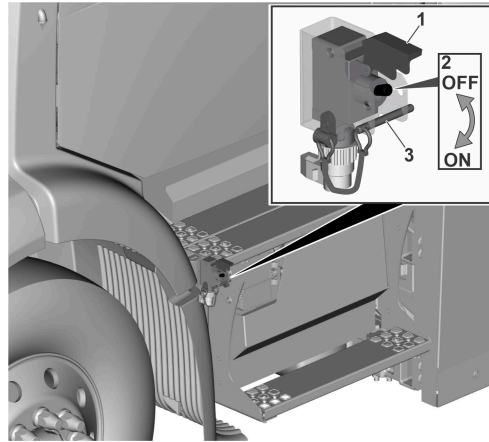

T3166323

- 1 Cap
- 2 Chassis switch
- 3 Lockout pin

When performing any work on the vehicle, to avoid accidental movement of the chassis switch from the off position to the on position, follow these steps:

- 1 Open the cap (1) and move the chassis switch (2) from the On position to the Off position.

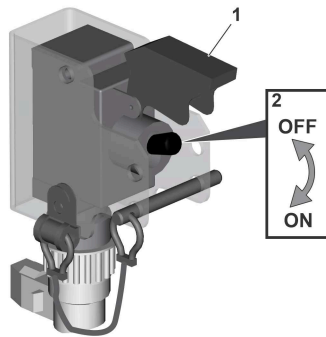

T3166478

Position ON

**2** Pull the lockout pin (3) from lower hole of the bracket and insert it into the upper hole of the bracket.

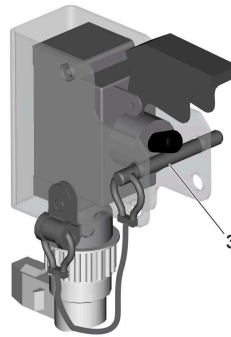

T3169687

When the work is completed:

**1** Remove the lockout pin (3) from the upper hole of the bracket and secure it in the lower hole of the bracket.

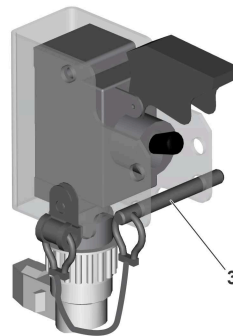

T3169688

**2** Turn the chassis switch to an On or Off position (based on your needs).

**3** Close the cap (1).

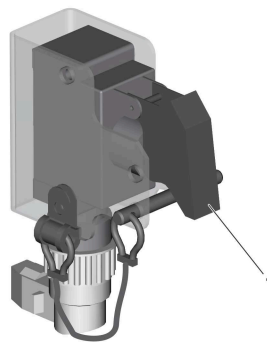

T3169689

The lockout pin in the upper hole of the bracket is to restrict the movement of the chassis switch from the Off position to the On position. Secure the lockout pin in the lower hole of the bracket when the vehicle is parked or being driven.

# Fire safety

## Basic principles – Working with lithium-ion batteries

Lithium-ion batteries are electrochemical storage system that use lithium in an ionic form. The battery cells contain electrodes, an electrolyte (lithium hexafluorophosphate (LiPF<sub>6</sub>) dissolved in a mixture of organic solvents) and different products providing different chemical and physical characteristics.

### Thermal risk

An internal event (quality problem in cells/electronics etc), or an external event (excessive external temperature, mechanical damage, water intrusion etc.) may be the origin of a thermal runaway where exothermic decomposition reactions may occur, resulting in fire and /or explosion.

Traction battery thermal runaway occurs when a battery cell or area within the battery cell exceeds maximum temperature rating set by the battery manufacturer. It is an unstoppable chain reaction result in rising of temperature rapidly within milliseconds and the energy stored in the battery discharge quickly.

Thermal runaway means a serious fault in the traction batteries that will lead to a fire in the traction batteries.

**Note:** Additional information can be found in the drivers manual.

### Chemical risk

The chemical products in the battery cells are flammable and can be dangerous to human health and environment. Decomposition or combustion products may also present a hazard to human health and the environment. These include hydrofluoric acid, phosphoric acid, fluorine compounds, carbon monoxide, hydrogen, hydrocarbon gases and carbon dioxide. The nature and quantity of the flammable and toxic gases emitted depend on numerous parameters such as the composition of the battery cell (cathode, solvents and electrolyte salt, additives, etc.), the state of charge and the mode of failure.

In the event of a fire, smoke or suspicious smell in the truck, it is important to take the correct actions. See the following instructions.

## Guidelines for Electrical Accident

One of Volvo's core values is safety. This is also reflected in the design of electric vehicles. If the correct routines are followed and appropriate protective measures are taken, there is virtually no risk of electrical accidents.

Although such accidents are unlikely, it is still good to know what to do in case an electrical accident occurs. The following is a general guideline for how to handle such situation.

- 1 **Shut off the electric power:** This could be done by using the emergency chassis cut-off switch.
- 2 **Attend to the injured and notify rescue services:** Follow local procedures for emergency situations.
- 3 **Report the accident:** This is an important step in preventing the accident from happening again.



T3170874

## Guidelines for Fire Incident

The following guidelines are to be considered general recommendations in case of thermal incidents related to electric vehicles.

In specific cases other procedures may be more appropriate. Always follow local guidelines and regulations when dealing with thermal incidents.

### In case of fires involving electric vehicles:

- 1 Alert nearby personnel and notify rescue services.
- 2 Prevent the fire from spreading to the traction batteries if possible. If not possible, evacuate the area.
- 3 Report the incident according to current reporting procedure.



T3170875

### In case of fire in the traction batteries:

- 1 Alert nearby personnel and notify rescue services.
- 2 Evacuate the area.
- 3 Report the incident according to current reporting procedure.



T3170876

## Fire, smoke, unusual smell, heat or sounds in traction battery area.

### **DANGER**

**Risk of serious personal injury or death**  
Do not try to extinguish the fire yourself.

### **DANGER**

**Risk of serious personal injury or death**  
Do not inhale the smoke, it is very toxic.

If there is a fire in or near the traction batteries, or if smoke is coming from the traction batteries or the area around them, do the following:

- 1 Evacuate the truck immediately and quickly move away from the truck.
- 2 Alert anyone who is nearby and secure the area around the truck.
- 3 Contact the emergency service in the country you are in. Inform them that your electric truck is on fire.

## Fire in another part of the truck

If there is a fire in another part of the truck (not in or near the traction batteries), do the following:

- 1 Evacuate the truck immediately.
- 2 Contact the emergency service in the county you are in. Inform them that your electric truck is on fire.
- 3 If you think that it is safe, extinguish the fire using ABC (powder) extinguisher other than traction battery area.
- 4 If the fire reaches the traction battery area, move away from the truck immediately.

The fire extinguisher is located next to the driver's seat, in the door opening.

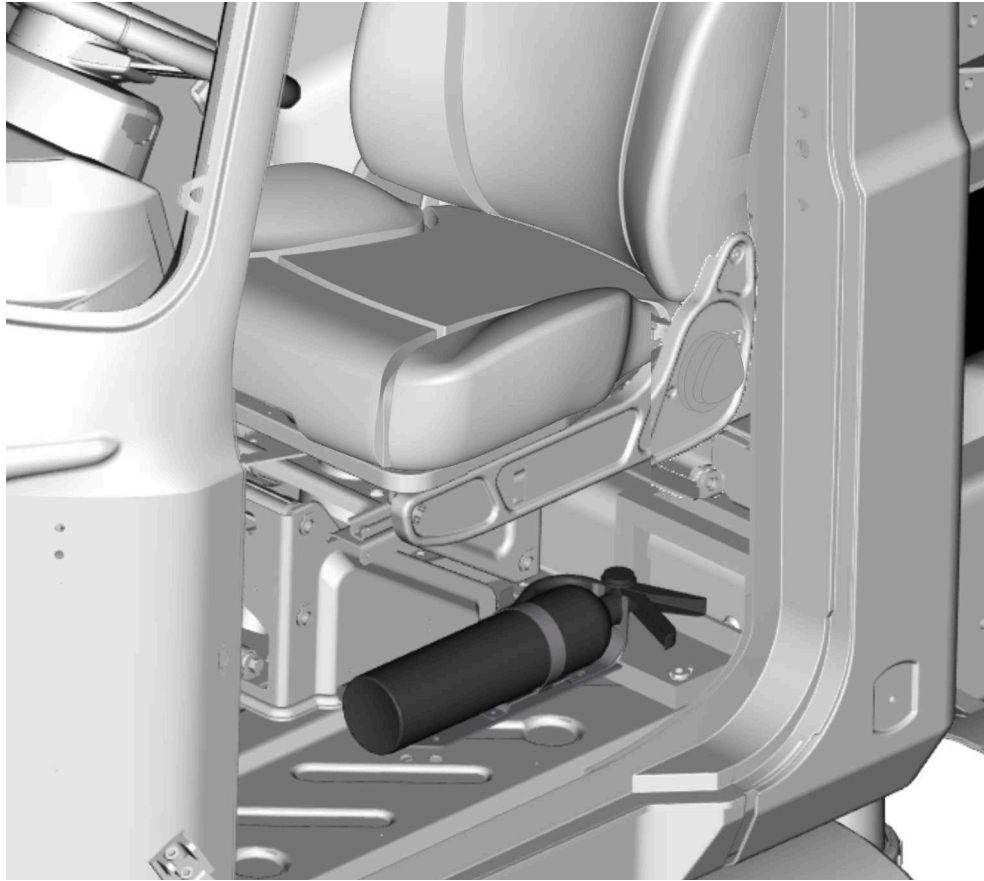

T0170532

**Fire extinguisher mounting position in the cab**

# Chassis

## Welding



### DANGER

#### Risk of serious personal injury or death

Welding directly on the ESS is not permitted as this can cause dangerous electric shocks, arcs or burns, which can result in serious personal injury or death.



### WARNING

#### Risk of component damage

Failure to follow the following instructions can result in damage to electrical components.

It is not permitted to weld in the wheelbase area because of the traction voltage (600 V/400 V) components.

It is permitted to weld outside the wheelbase area, in the rear overhang.

**The welding process that applies to conventional trucks, also applies to electric trucks.**



### CAUTION

It is not permitted to weld on this vehicle without decommissioning.



### CAUTION

Decommissioning and commissioning must only be carried out by personnel with adequate certification.

- Carry out the vehicle safety decommissioning procedure.
- Welding directly onto electrical components is not permitted.
- Electric components must be given adequate protection if the welding is carried out close to them.
- Ground the welding equipment as close as possible to the welding area.
- Protect the vehicle from splashing, which may occur during welding.

# Drilling

The drilling process that applies to conventional trucks, also applies to electric trucks.

## **DANGER**

### **Risk of serious personal injury or death**

When drilling, make sure that there are no traction voltage (400/600 V) circuit components that could be damaged.

## **CAUTION**

It is not permitted to drill on this vehicle without decommissioning.

## **CAUTION**

Decommissioning and commissioning must only be carried out by personnel with adequate certification.

# Painting

Contact the vehicle manufacturer before carrying out any painting work.

## **DANGER**

### **Risk of serious personal injury or death**

Before carrying out any painting work, it is mandatory to deactivate the electrical system (24 V and 600 V).

Perform the following to deactivate the electrical system:

- Turn the starter switch to OFF position and remove the key.
- Set the chassis switch to OFF position.
- Disconnect the negative and positive terminals of the 24 V battery.

## **CAUTION**

Do not move the vehicle without disconnecting the propeller shaft, after setting the chassis switch to Off position.

**Note:** Traction voltage cables are orange in color for easy identification. Do not paint or change the color of traction voltage cables.

## **CAUTION**

To avoid damage to the traction battery (600 V battery), do not exceed the following drying process of the paint:

- The maximum drying temperature 75° C (167 ° F).
- The maximum drying time (30 minutes).

If the BEV is painted with more than one color, allow the BEV to cool down to room temperature 20° C (68 F) before it is sent to drying oven.

# Towing



## CAUTION

The vehicle may only be towed with the propeller shaft disconnected.

Refer to the driver's handbook for more information on towing.

# Washing



## CAUTION

Do not wash the truck, if any connector in the traction voltage system is improperly connected or the truck is disassembled in any way.



## CAUTION

Before washing the truck, make sure that the charging inlet cover is securely fastened and fully covers the charging inlet.

## General

Regular cleaning helps to maintain the value of your truck. Wash the truck more often in winter conditions or other dirty driving conditions.

The waste water from cleaning the truck contains chemicals and pollutants that are bad for the environment. Use environmental friendly detergents and ensure that the truck is cleaned in a facility where the waste water is collected.

## Notes

---

---

---

---

---

---

---

---

---

---

## Washing with high pressure

Be careful when washing the truck with a high-pressure washer. If water and dirt penetrate into components, then that can cause damage over time.

Do not use a high-pressure washer to clean the following components:

- Traction batteries
- Components in the traction voltage system
- Universal joint crosses
- Support bearings
- Sliding interfaces
- Joints
- Sealings
- Connectors
- Electrical components
- Air inlets
- Ventilation, for example, transmission and oil reservoirs.

Tires and air suspension bellows can be cleaned with a high-pressure washer, but do not use pulsating high pressure as it can damage them. The damage is not visible but may eventually cause tires or bellows to rupture.

The radiator can also be cleaned with high pressure, but, be careful as the radiator fins can be easily damaged.

**Note:** Minimum distance between the high-pressure nozzle and the washing surface is:

Approximately 70 cm (27.5 inches) with a round concentrated jet.

Approximately 30 cm (11.8 inches) with a flat widespread jet.

## Washing the cab



### CAUTION

When washing the windshield, ensure that the windshield wipers are switched off. Otherwise there is a risk of fingers being trapped by the wiper blades.

The truck must be washed when it is dirty. Especially in winter when road salt and moisture can cause corrosion.

The following points must be followed to avoid paint damage and to achieve good results when washing:

- Washing method: Use a pressure washer primarily. For the dirt that cannot be removed using this method, try to remove with a brush or sponge with a best suited cleaning agent for the type of dirt. There is a risk of scratching the paint while using a brush without prior high pressure washing or washing in brush washers that are poorly maintained (worn, dirty brushes etc.).
- Washing chemicals, general: Different agents are recommended for different types of dirt. Always follow the manufacturer's recommendations for use, dosage and maximum temperature.
- Avoid chemicals drying onto the paint surface.
- Washing detergent: Avoid using strong alkaline agents (pH >12). Do not wash the truck in direct sunlight. Rinse with plenty of cold water before applying chemicals. If the temperature is above (30° C or 86 ° F), wash small areas and then rinse clean to avoid long exposure time or chemicals drying on the surface. Always rinse with plenty of water after using washing detergent.

## Washing the chassis

Both chassis and cab must be washed when they are dirty. Be careful with high pressure washing of axles, joints and other moving parts, where water and dirt can be forced in. Avoid flushing away lubricant. Should this still happen, make sure to re-lubricate the components.

Washing detergent: Avoid using strong alkaline agents (pH >12). Do not wash the truck in direct sunlight. Rinse with plenty of cold water before applying chemicals. If the temperature is above (30° C or 86 ° F), wash small areas and then rinse clean to avoid long exposure time or chemicals drying on the surface. Always rinse with plenty of water after using washing detergent.

**Note:** Never spray water directly onto the traction batteries or other components in the traction voltage system. Also, do not spray water directly onto sealings, gaskets or electric equipment (such as cables or connectors) in the 24 V system.

# Body start dimensions

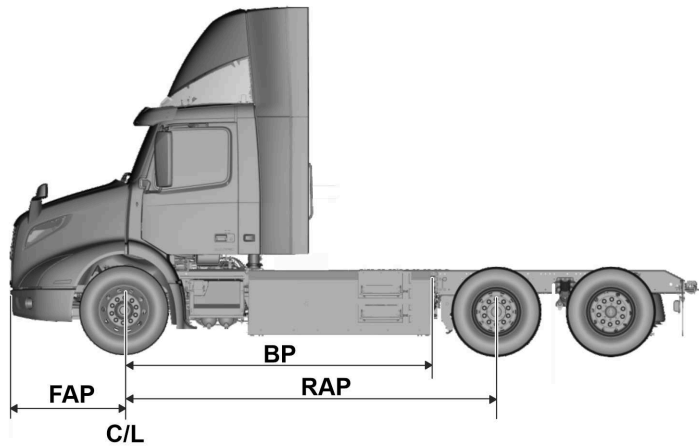

T7185989

Body dimensions for BTMS at BOC

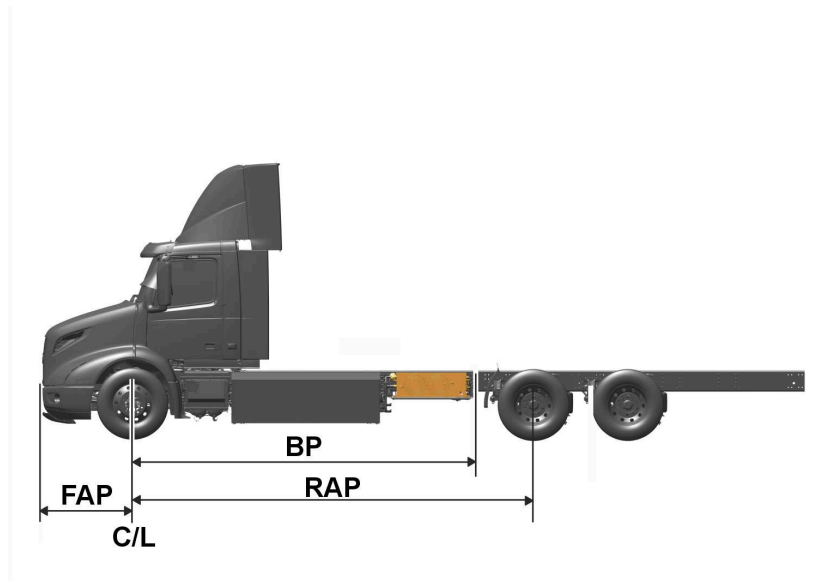

T9212889

Body dimensions for BTMS at Side of frame

	Tractor Vehicle	Rigid Vehicle
<b>BP</b>	3551 mm (139.8 inches)	3551 mm (139.8 inches) 4965 mm (195.5 inches) <sup>1</sup>
<b>C/L</b>	Centerline of front axle	
<b>FAP</b>	1297.5 mm (51 inches)	
<b>RAP</b>	For 4x2 vehicles – 4300 mm (169.3 inches) For 6x2 vehicles – 5600 mm (220.5 inches) For 6x4 vehicles – 4450 mm (175.2 inches)	For 4x2 vehicles – RAP increases every 50 mm (1.9 inches) starting from 4300 mm (169.3 inches) For 6x4 vehicles – RAP increases every 50 mm (1.9 inches) starting from 4400 mm (173.2 inches)

<sup>1</sup> Applicable only for vehicles with a RAP greater than 5700 mm (224.4 inches).

# Body/Subframe Mounting

For more information about Body Attachments, refer to the Volvo Body Builder manual section 7.  
<https://www.volvotrucks.us/parts-and-services/services/body-builder-support/manuals/>

## Body Dimensions

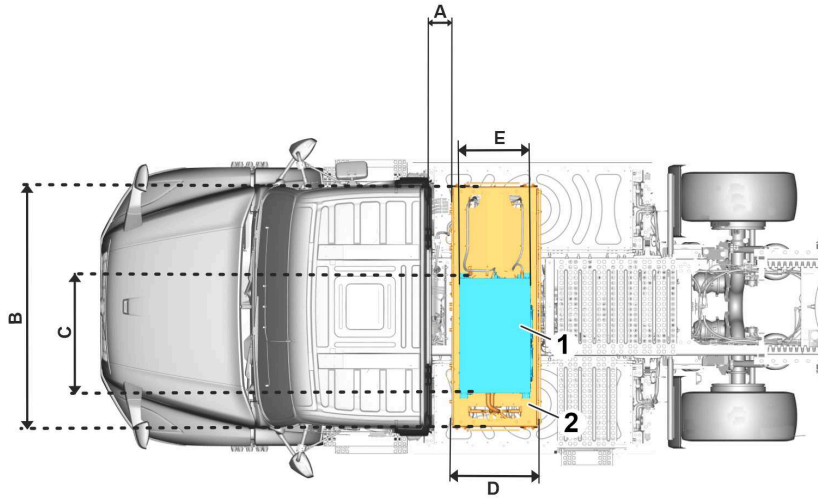

T7182223

Body dimension for tractor vehicles

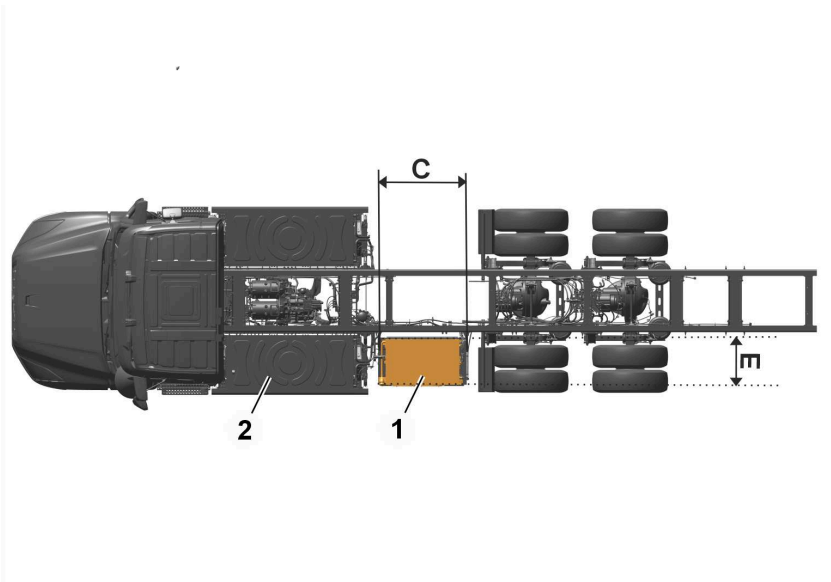

T9212890

Body dimension for rigid vehicles

Body builder must maintain a minimum body start distance **(A)** from the BOC (Back of Cab) to Gantry:

- **A:** 130 mm (5.1").

The dimensions of BTMS (1) and traction battery (2) are shown below:

- **B:** 2161 mm (85.1")
- **C:** 1130 mm (44.5")
- **D:** 820 mm (32.2")
- **E:** 676 mm (26.6").

**Note:** The BTMS installation environment must ensure that there is a minimum of 150 mm (6") clearance between the exhaust ports and any obstructions. A clearance of 75 mm (3") is acceptable for air intakes.

*Notes*

---

---

---

---

---

---

---

---

---

---

## Gantry side dimensions

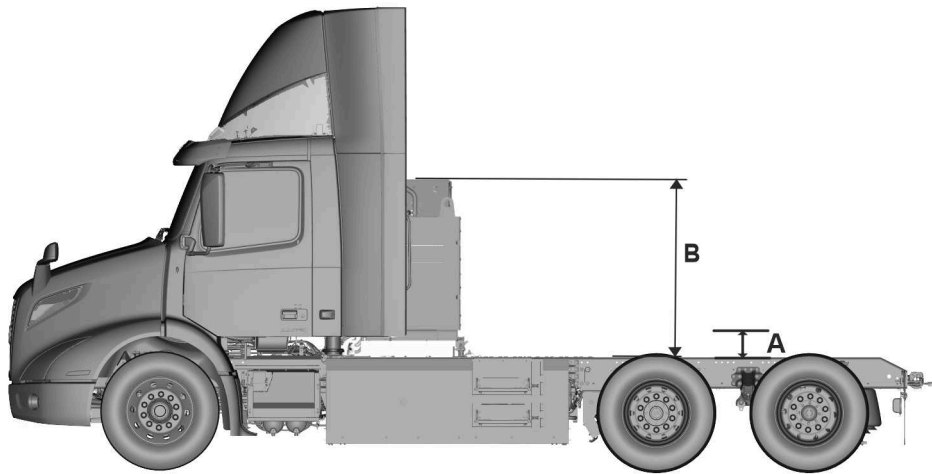

T7182225

Gantry side dimensions for tractor vehicles

A minimum subframe height (A) required for traction battery maintenance is:

- **A:** 140 mm (5.5") for distribution type truck.

The height (B) from top of frame rail is:

- **B:** 1361 mm (53.5").

**Note:** Do not install anything just above the traction batteries. Maintain a minimum of 140 mm (5.5") subframe height to install anything above the traction batteries.

## Pneumatic Connections

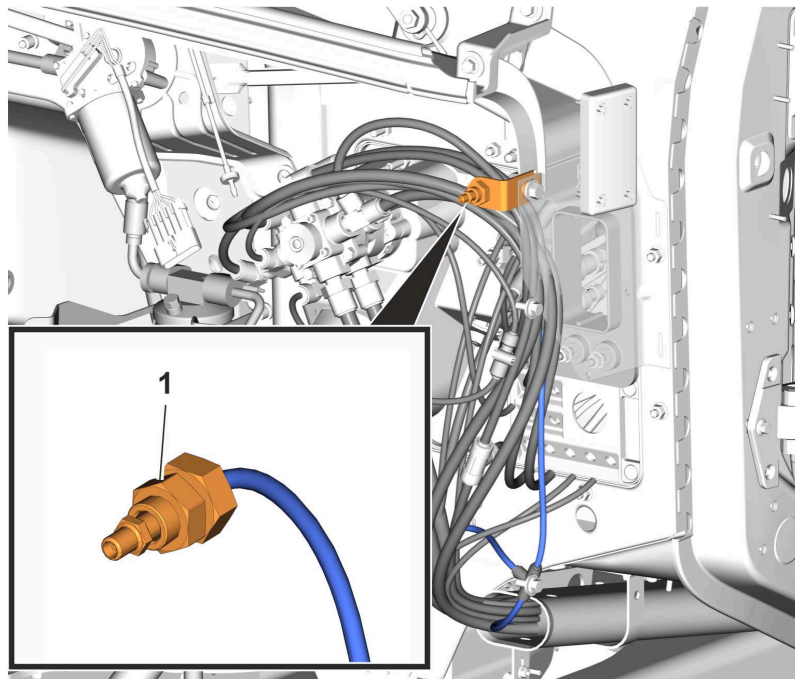

T5178367

Schrader valve (1) used to fill pneumatic system to operate anything connected to the system.

## BEV cooling systems

There are 2 BEV cooling systems:

- 1 Passive cooling system for CESS-P (Cooling energy storage system - Passive)
- 2 Active and passive cooling system for CESS-A (Cooling energy storage system - Active)

**Note:** It is not permitted to connect additional heating supply to the cooling system in BEV.

### Passive cooling system for CESS-P

#### Overview

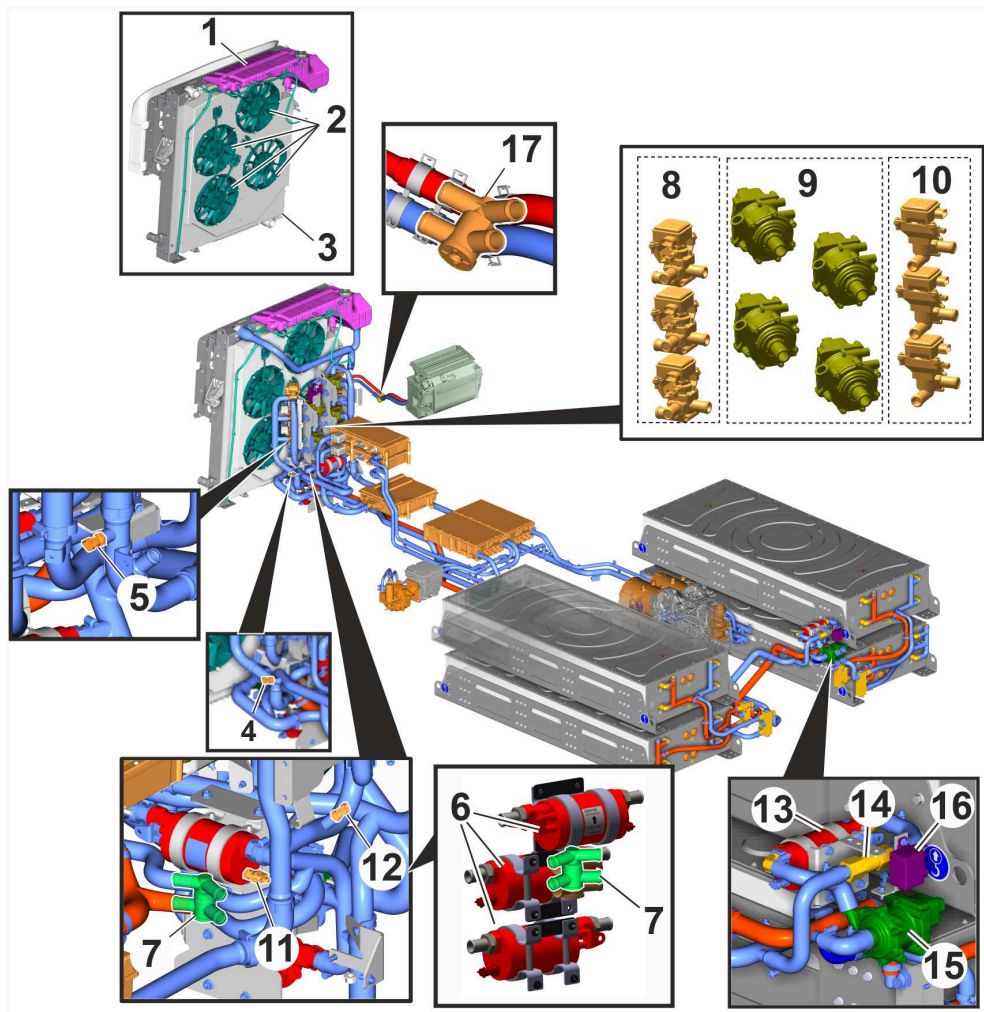

T2180897

1. Expansion tank	7. Pressure valve (27 kPa)	13. Traction battery heater
2. Fan	8. Three-way valve (radiator inlet)	14. Non-return valve
3. Radiator	9. Coolant pump	15. Traction battery coolant pump
4. Coolant temperature sensor (electromobility components outlet)	10. Three-way valve (radiator outlet)	16. Heater relay

5. Coolant temperature sensor (traction battery inlet)	11. Temperature sensor cab heater	17. Pressure valve (35 kPa)
6. Cab heater	12. Coolant temperature sensor (coolant pump outlet)	

## Cooling system CAN (Controller Area Network) subnet

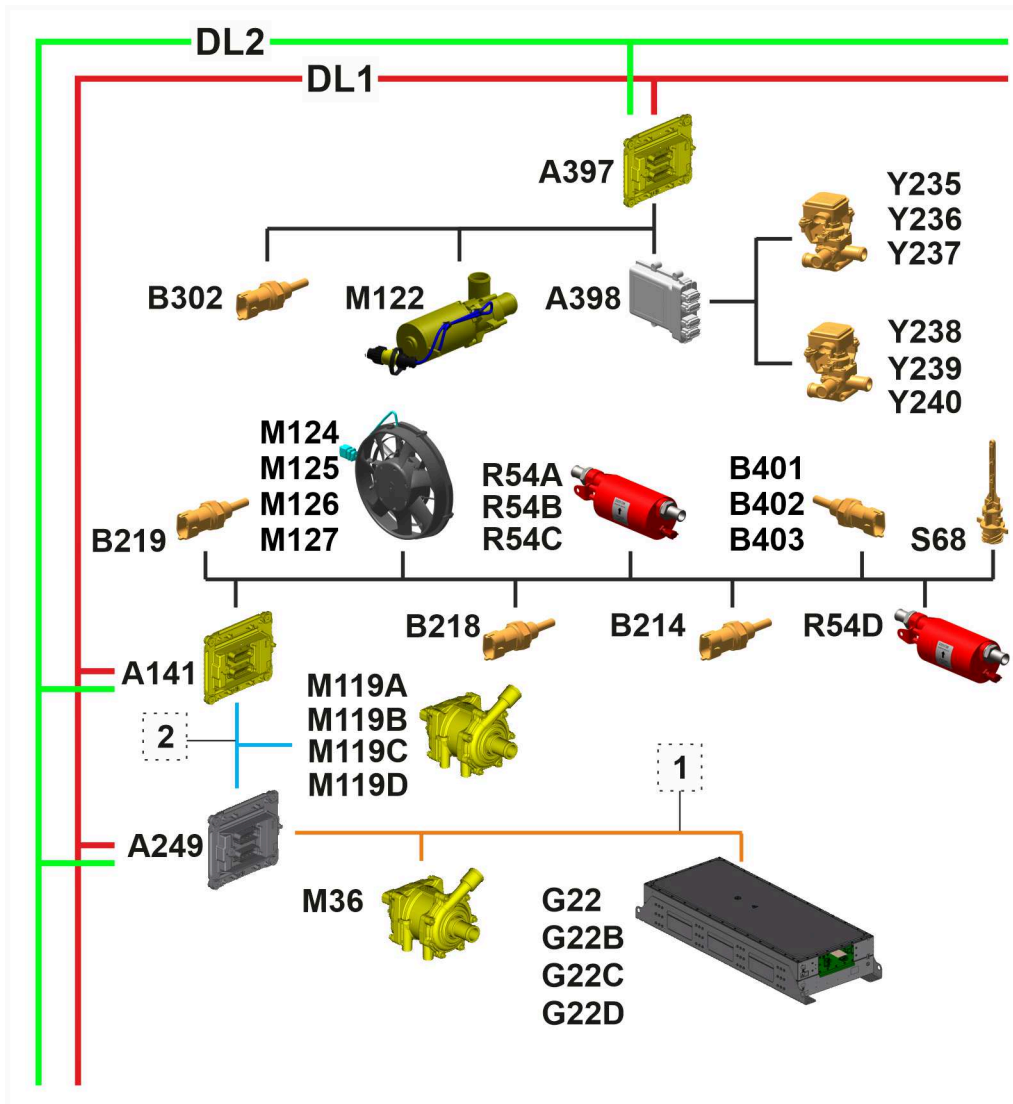

T2180898

DL 1	Data Link 1 (J1939)
DL 2	Data Link 2 (J2284)
1	DL 14 (emob subnet 1)
2	DL 12 (emob subnet 4)
A141	HPCU (Hybrid Powertrain Control Unit)
A249	ESCM (Energy Storage Control Module)
A397	EVCM (Electromobility Vehicle Control Module)
A398	Coolant valve control box

B401, B402, B403	Temperature sensor cab heater
B219	Temperature sensor ESS (Energy Storage System) heater
B218	Coolant temperature sensor (coolant pump outlet)
B214	Coolant temperature sensor (traction batteries inlet)
B302	Coolant temperature sensor (electromobility components outlet)
G22, G22B, G22C, G22D	Traction battery
M124, M125, M126, M127	Fan
M119A, M119B, M119C, M119D	Coolant pump
M36	Traction battery coolant pump
M122	Cab heater pump
R54A, R54B, R54C	Cab heater
R54D	Traction battery heater
S68	Coolant level sensor
Y235, Y236, Y237	Three-way valves (radiator inlet)
Y238, Y239, Y240	Three-way valves (radiator outlet)

## Coolant draining and bleeding points

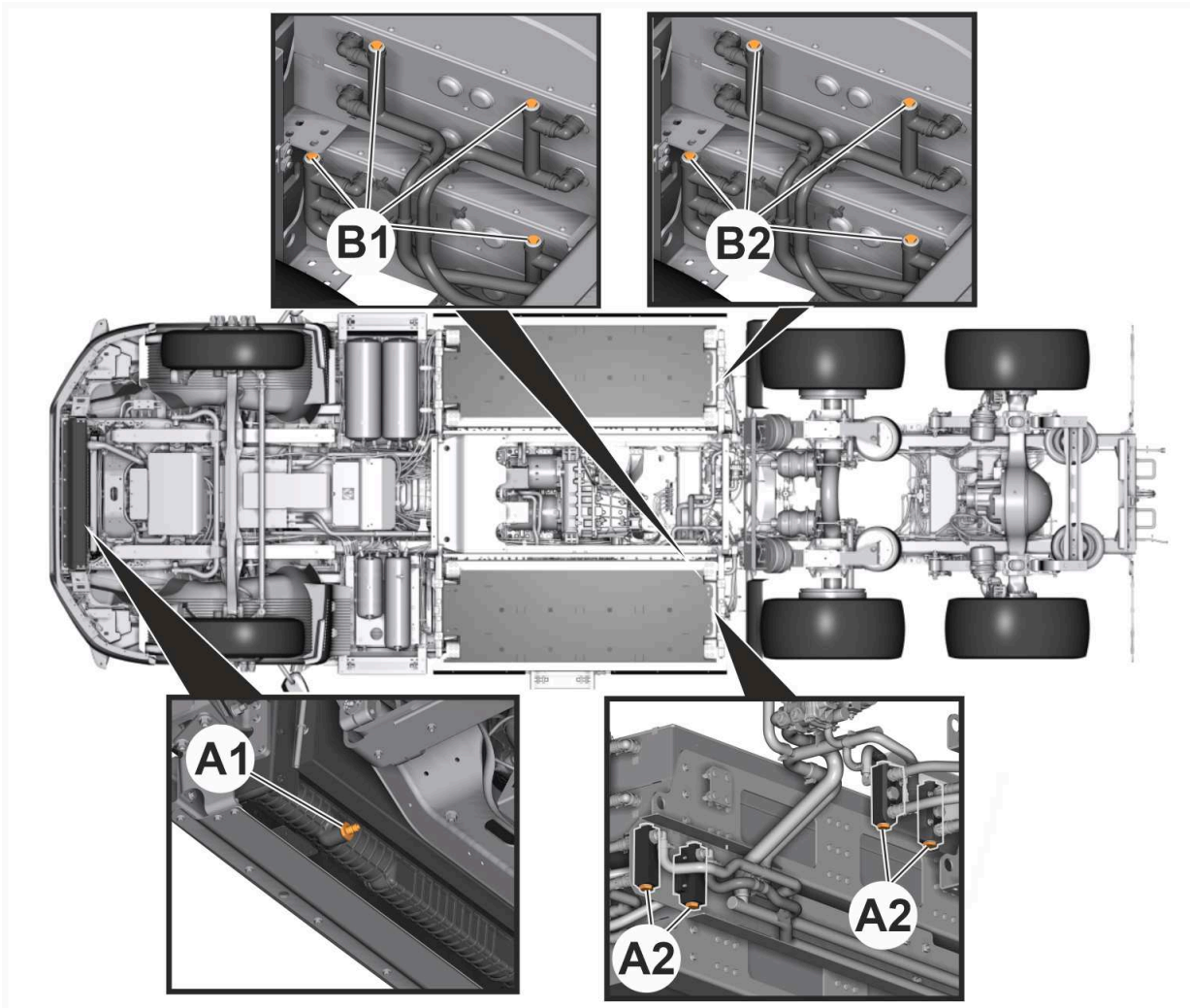

T2180899

A1	Radiator lower tank draining plug
A2	ESS cooling dispenser plug (bottom only)
B1, B2	ESS cooling pipe bleeding screws

## Available functions in the various truck modes

Mode	Function				
	Traction battery heating	Cab heating	Traction battery cooling	Electromobility components cooling	Air conditioning
Running	X	X	X	X	X
Preconditioning	X		X	X	
Charging	X		X	X	
After-run	X		X	X	
Workshop	X		X		

The modes of the electric truck are:

- 1 **Running:** In this mode, the truck driveline is active. The driver is operating the truck.
- 2 **Preconditioning:** In this mode, the truck is idle and it prepares for the next task by ensuring the right level of temperature in the driveline and traction batteries.
- 3 **Charging:** In this mode, the truck is idle and the charging connector is connected to charge the traction batteries.
- 4 **After-run:** In this mode, the truck is not plugged in for charging. It aims at setting minimum thermal conditions to ensure truck reliability and lifetime.
- 5 **Workshop:** In this mode, the truck is not plugged in for charging. It helps support various workshop operations.

There are two sub-modes:

- Filling: In this mode, all three-way valves are set to 50% valve opening.
- Deaerating: In this mode, the cooling system is activated every 2 minutes.

When the truck key is turned to Off position and the chassis switch is in On position, the ATVSA (Automatic Traction Voltage System Activation) monitors the post-run modes and controls the cooling and heating in the electric truck.

## Coolant details

### Coolant System Capacities

Chassis Model	Coolant Capacity in Liters (Gallon)
VNR Electric (Total Cooling System, Coolant Capacity)	57 (15)
Refill Quantity	approximately 51 (13.5)

### Coolant type

The coolant used in cooling the system is Extended Life XLC Coolant Nitrite Free.

# Active and Passive cooling system for CESS-A

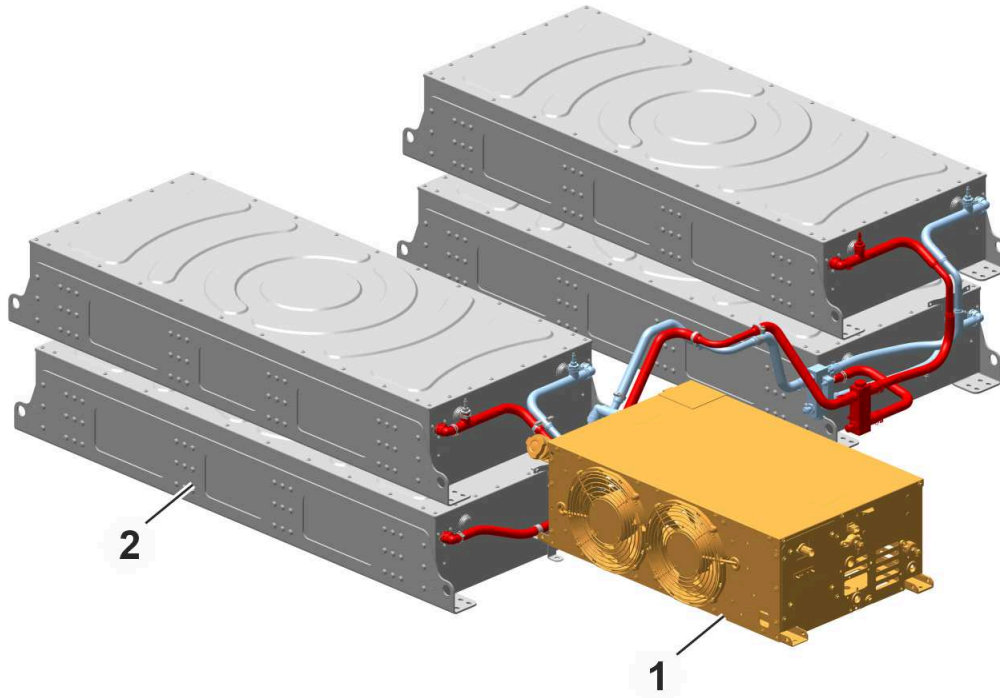

T2212484

**Active cooling for truck with 4 battery configuration**

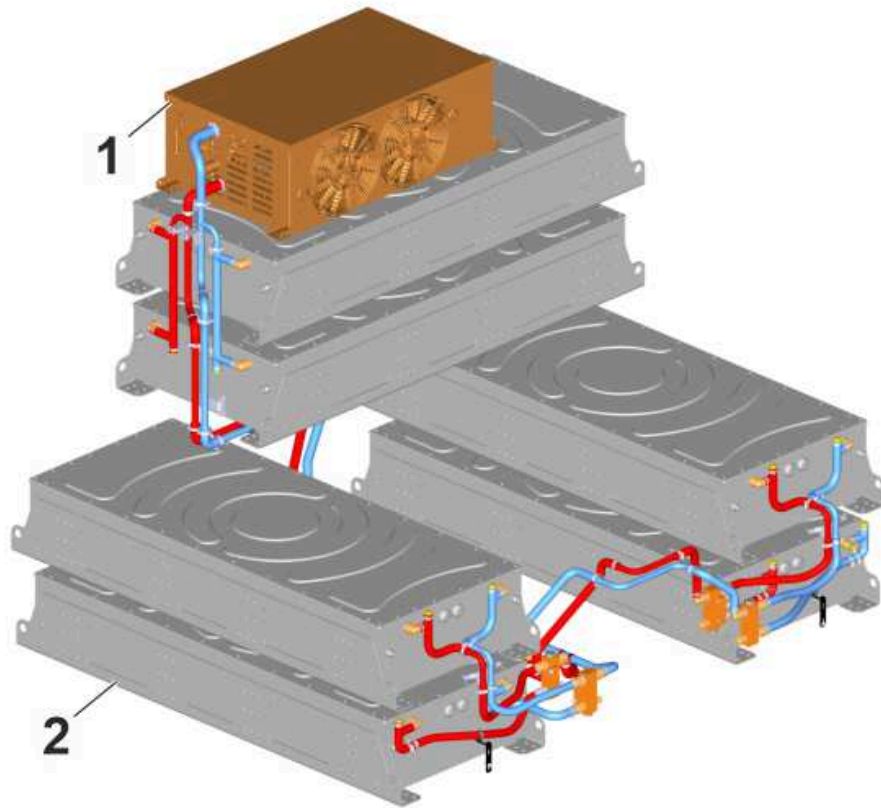

T2181413

#### Active cooling for truck with 6 battery configuration

Active cooling is done for traction voltage battery using BTMS unit.

1. BTMS (Battery Temperature Management System)
---

2. Traction Battery
---------------------

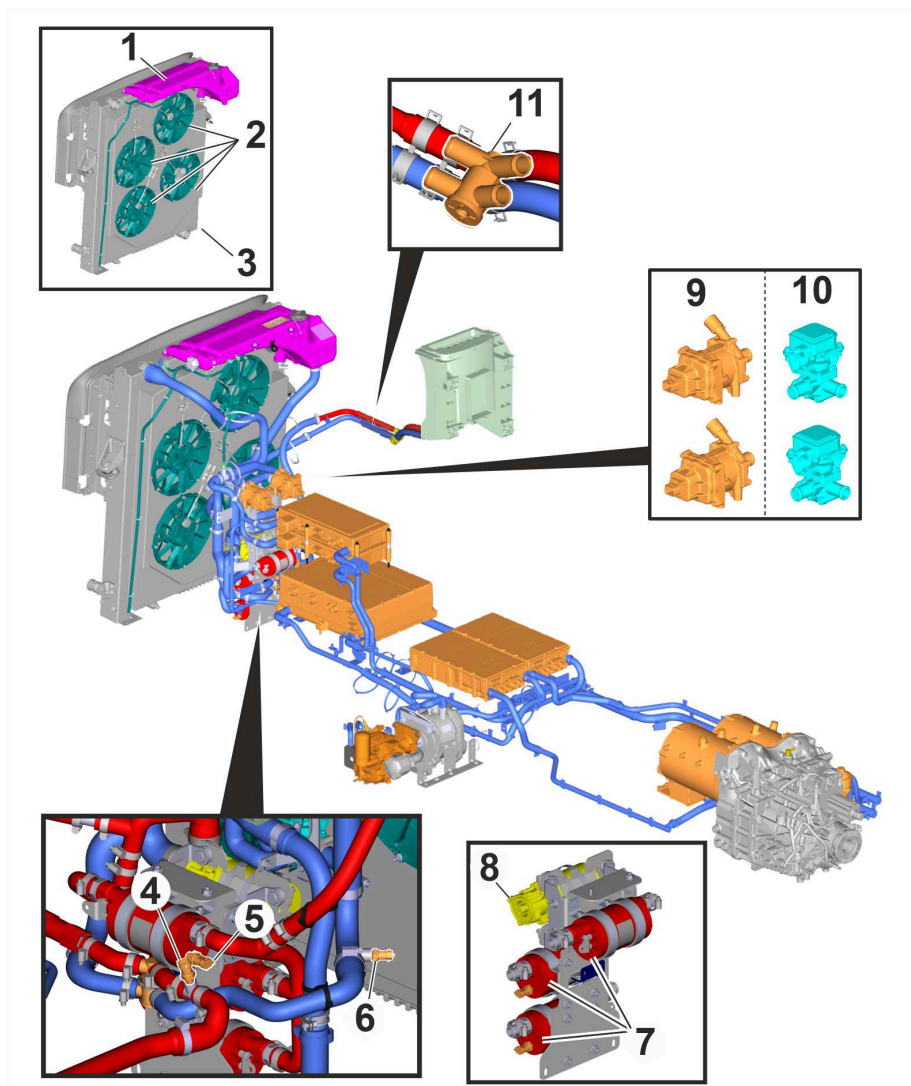

T2181412

### Passive cooling

Passive cooling is done for electromobility components.

1. Expansion tank	7. Cab heater
2. Fan	8. Cab heater pump
3. Radiator	9. Coolant pump
4. Coolant temperature sensor (electromobility components outlet)	10. Three-way valve
5. Temperature sensor cab heater	11. Pressure valve (35 kPa)
6. Coolant temperature sensor (coolant pump outlet)	

# Cooling system CAN (Controller Area Network) subnet

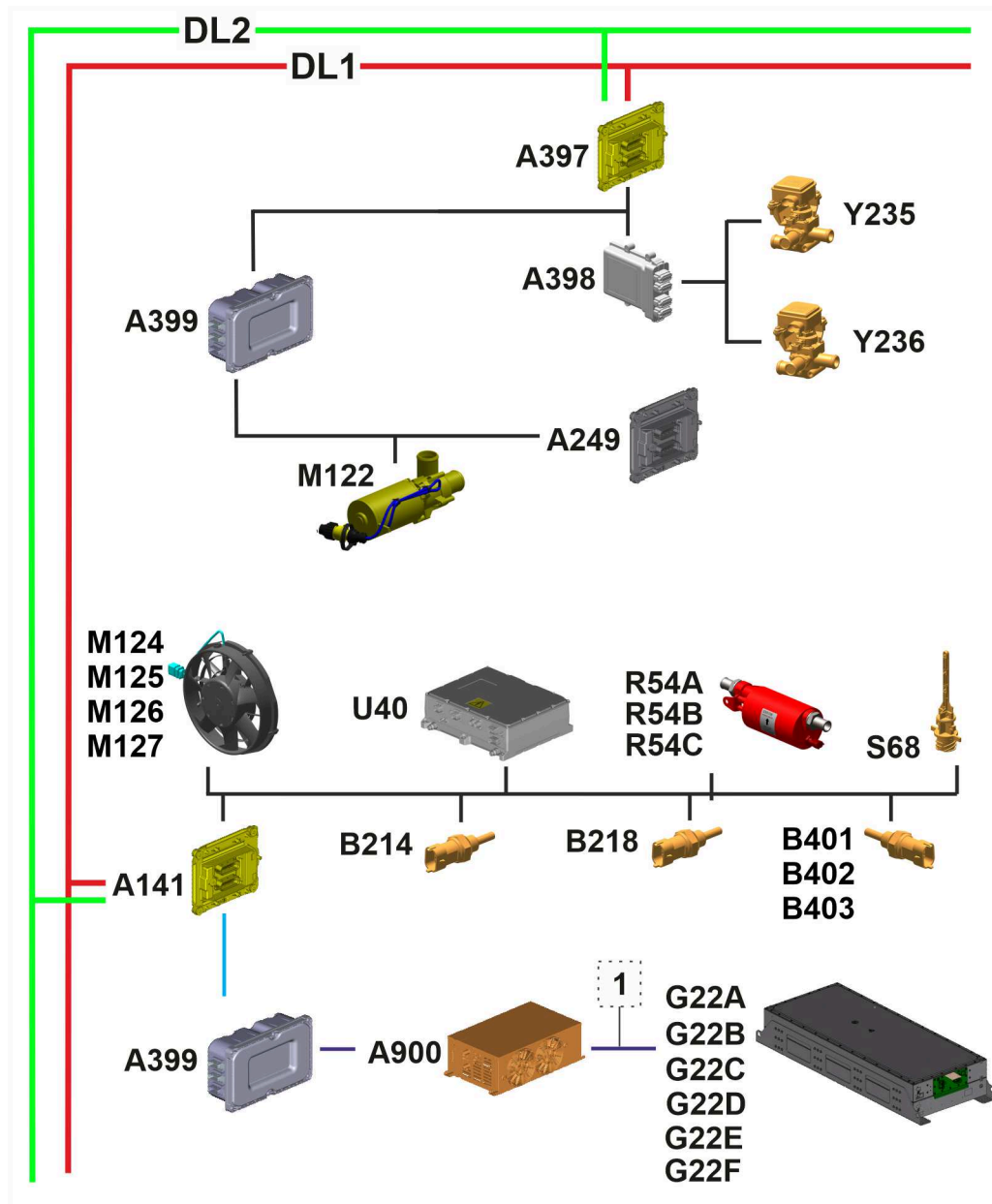

T3181688

DL 1	Data Link 1 (J1939)
DL 2	Data Link 2 (J2284)
1	DL 13 (emob subnet 2)
A141	HPCU (Hybrid Powertrain Control Unit)
A249	ESCM (Energy Storage Control Module)
A397	EVCM (Electromobility Vehicle Control Module)
A900	BTMS (Battery Temperature management system)
A398	Coolant valve control box
A399	Fuse and relay center

U40	OCEPS (On-board Charger and Electric Power Supply)
B401, B402, B403	Temperature sensor cab heater
B218	Coolant temperature sensor (coolant pump outlet)
B214	Coolant temperature sensor (traction batteries inlet)
G22, G22B, G22C, G22D, G22E, G22F	Traction battery
M124, M125, M126, M127	Fan
M122	Cab heater pump
R54A, R54B, R54C	Cab heater
S68	Coolant level sensor
Y235	Three-way valves (radiator inlet)
Y236	Three-way valves (radiator outlet)

# Coolant draining and bleeding points

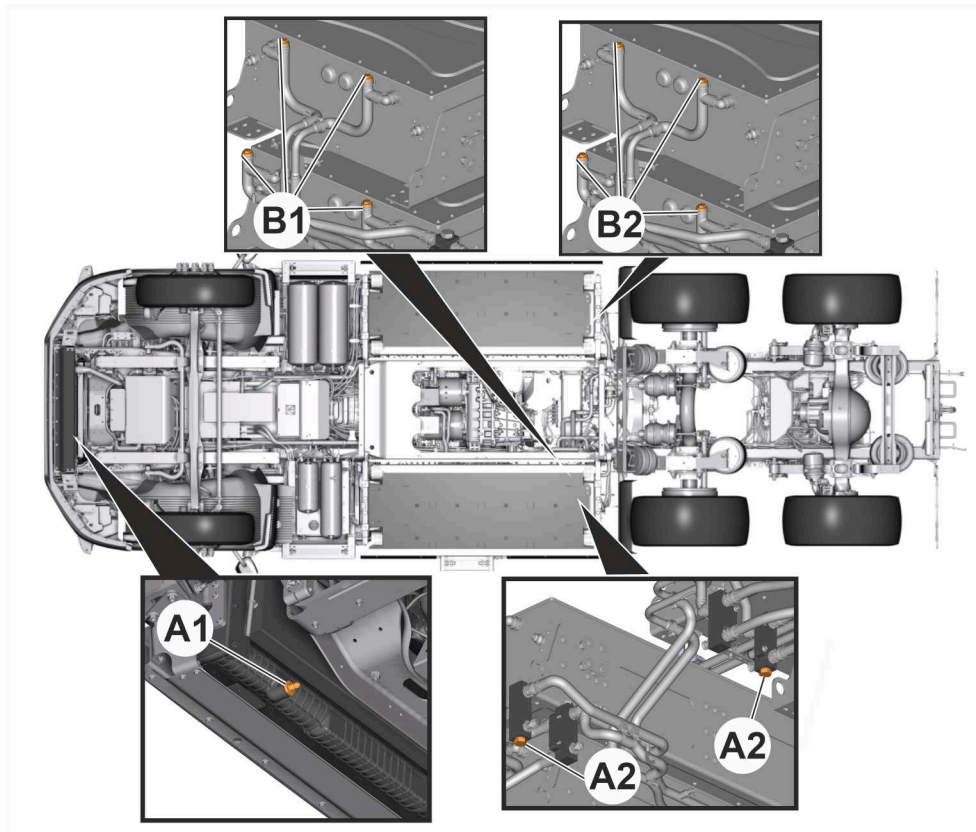

T2181689

A1	Radiator lower tank draining plug
A2	ESS cooling dispenser plug (bottom only)
B1, B2	ESS cooling pipe bleeding screws

## Available functions in the various truck modes

Mode	Function				
	Traction battery heating	Cab heating	Traction battery cooling	Electromobility components cooling	Air conditioning
Running	X	X	X	X	X
Preconditioning	X		X	X	
Charging	X		X	X	
After-run	X		X	X	
Workshop	X		X		

The modes of the electric truck are:

- 1 **Running:** In this mode, the truck driveline is active. The driver is operating the truck.
- 2 **Preconditioning:** In this mode, the truck is idle and it prepares for the next task by ensuring the right level of temperature in the driveline and traction batteries.
- 3 **Charging:** In this mode, the truck is idle and the charging connector is connected to charge the traction batteries.
- 4 **After-run:** In this mode, the truck is not plugged in for charging. It aims at setting minimum thermal conditions to ensure truck reliability and lifetime.
- 5 **Workshop:** In this mode, the truck is not plugged in for charging. It helps support various workshop operations.

There are two sub-modes:

- Filling: In this mode, all three-way valves are set to 50% valve opening.
- Deaerating: In this mode, the cooling system is activated every 2 minutes.

When the truck key is turned to Off position and the chassis switch is in Off position, the ATVSA (Automatic Traction Voltage System Activation) monitors the post-run modes and controls the cooling and heating in the electric truck.



# Electrical/Electronic information



## CAUTION

If the vehicle is to be parked for a long period, set the chassis switch to the OFF position. In addition, the SOC of the traction batteries must be checked every month. If the low SOC warning light comes on, recharge the traction batteries.

## Battery Charging

### 24 V System Batteries Charging

The 24 V system has two 12 V batteries connected in series to provide 24 V output. A battery equalizer is used to equalize the voltage between two 12 V batteries.

The traction batteries charge the 24 V system batteries through DC/DC converter. The DC/DC converter is used to step-down the 600 V from traction batteries to 24 V to charge the 24 V system batteries. When the 24 V system batteries are fully discharged, Always disconnect the battery cables and charge each battery separately. This procedure prevents the transfer of high voltage to the battery and also from damaging the other system circuits. For more information, Refer to driver's manual.

**Note:** Always turn-off the chassis switch before removing the 12 V batteries or performing any maintenance activities on 12 V batteries.

### Traction Battery Charging



## CAUTION

If the vehicle is to be parked for a long period, set the chassis switch to the OFF position. In addition, the SOC of the traction batteries must be checked every month. If the low SOC warning light comes on, recharge the traction batteries.

**Note:** If the 24 V system batteries are fully discharged due to any unnoticed battery consumption or for any other reasons, it is important to charge the 24 V system batteries before charging the traction batteries.

### Charging

There are two ways to charge the traction batteries:

- Charging while driving, by regenerative braking (refer to driver's handbook).
- DC charging can provide up to 150 kW.

The charging duration depends on the following conditions:

- The capacity of the traction batteries
- Current state of charge of the traction batteries
- Capacity of the power source and the charging infrastructure
- Temperature of the traction battery cell.

The optimum charging strategy for the truck depends on the truck specification and how it is used. Contact Volvo Trucks dealer for more information.

## Charging Interface

A vehicle may have any one of the following charging interface.

The charging interface is provided for recharging the traction batteries. There are two types of charging interface:

- CCS1 – only supports DC charging.

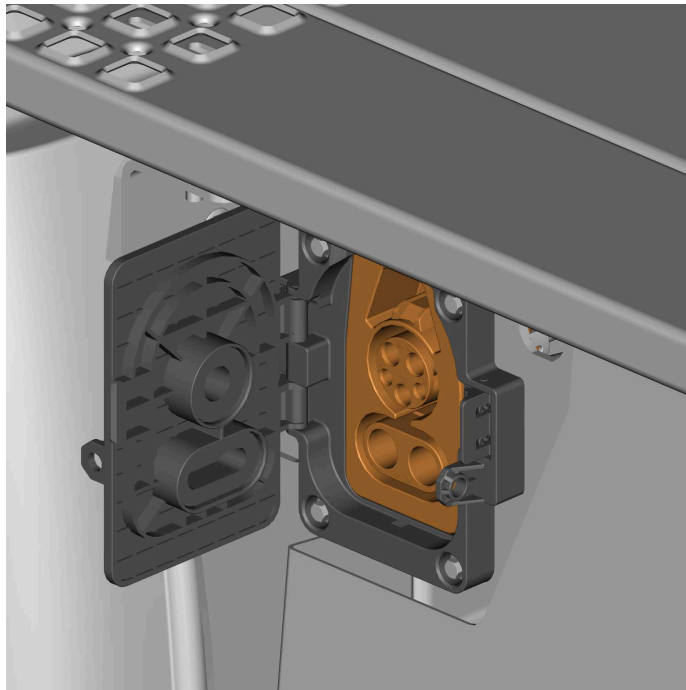

T3166326

- CCS2 – supports both AC and DC charging (AC charging option is not applicable for VNR electric).

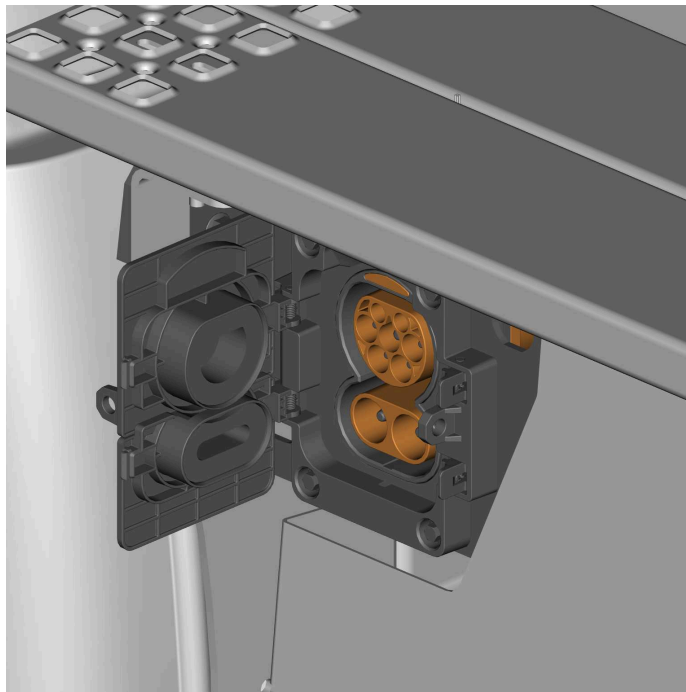

T3166327

## Charging Connectors

There are two types of charging connectors: Combo-1 and Combo-2.

- The charging interface CCS1 uses Combo-1 charging connector and supports only for DC charging.  
Combo-1 connector (DC charging)

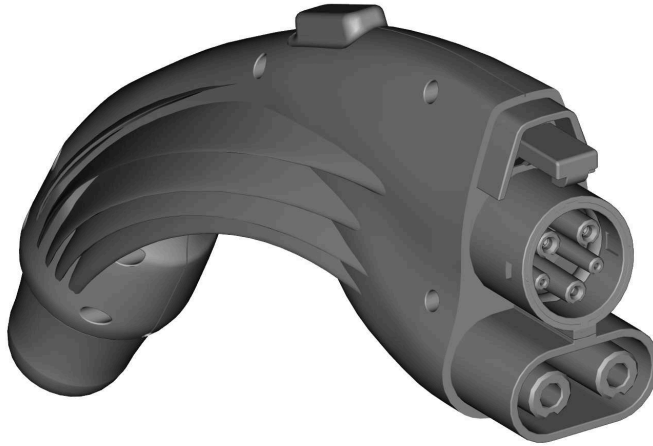

T3166316

- The charging interface CCS2 uses Type-2 charging connector for AC charging (not applicable for VNR Electric) and Combo-2 charging connector for both AC and DC charging.  
Combo-2 connector (AC and DC charging)

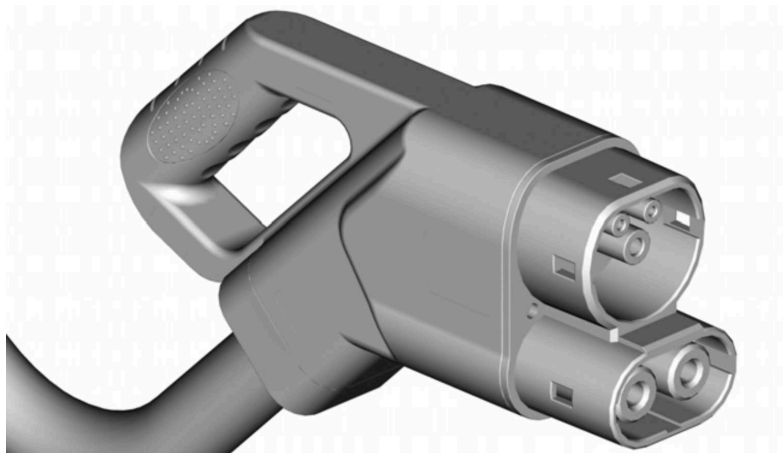

T3166322

- The CCS2 charging interface is compatible with Combo-2 and Type-2 charging connectors. The Combo-2 charging connector is used for DC charging and the Type-2 charging connector is used for AC charging.

Type-2 connector (AC charging)



T3191691

## Start Charging

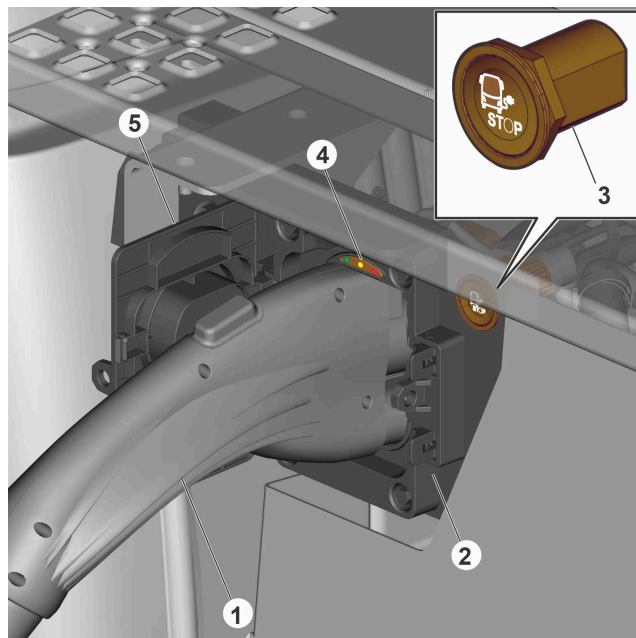

T3166320

- 1 Charging connector
- 2 Charging inlet
- 3 Charging stop button
- 4 Indicator lamp
- 5 Charging inlet cover.

The following conditions must be met to start charging the traction batteries:

- The truck is stationary
- The parking brake is applied
- The chassis switch in ON position.



## WARNING

Make sure that the charging cable, connector and charging inlet are not damaged, dirty or wet. Do not use charging equipment that is in bad condition.



## WARNING

If the charging inlet is dirty, do not clean it yourself. Contact the Volvo Trucks dealer.

- 1 Make sure that the charging cable is properly connected to the charging station or power outlet.
- 2 Remove the cover from the charging inlet.
- 3 Align the connector with the charging inlet and push the connector fully into the charging inlet.

The connector is locked in position by a locking pin. This initiates charging procedure. During this procedure, the indicator lamp next to the charging inlet flashes yellow.

**Note:** It can take up to 15 seconds for the truck to prepare for charging.

- 4 If the charging starts automatically, wait for the indicator lamp to switch to a green, flashing light.

If the charging does not start automatically, wait for the indicator lamp to switch to a yellow, steady light, then start the charging from the charging station.

- 5 During charging, the indicator lamp flashes green. When the traction batteries are fully charged, it changes to a green, steady light.

**Note:** During charging, it is normal that the connector and the charging inlet become warm. If the connector or the charging inlet appears to be warmer than normal, stop the charging immediately. Contact the authorized Volvo dealer.

## Stop charging

- 1 Press the stop button (located next to the charging inlet).

The indicator lamp turns on with yellow, steady light. The charging is stopped and the locking pin is retracted.

- 2 Wait until the indicator lamp turns off, then pull the connector straight out from the charging inlet.

If the connector cannot be pulled out, retract the locking pin manually. Refer to 'Manually retracting the locking pin'.

- 3 Install the charging inlet cover.



## WARNING

Make sure that the cover is installed correctly and it fully covers the charging inlet. The charging inlet must be protected from dirt and water.

## Signals during charging

The LED indicators in the charging interface give basic information about the charging.

LED Indicator Color	Steady/Flashing	Description	Action Required
Green	Steady	The traction batteries are fully charged	Disconnect the charging cable if you want to drive away, otherwise no action is needed
Green	Flashing	Charging is about to start or charging	No action is needed

Yellow	Steady	Charging is paused	Truck or charger has paused charging: If possible, start the charging from the charging station. If it is not possible to start the charging, wait for the scheduled charging to begin
		Charging stop switch is pressed	Disconnect the charging cable
Yellow	Flashing	A charging cable is connected to the charging interface but the charging has not started yet	Wait for the charging to start automatically or, if needed, start the charging from the charging station
Red	Steady	A fault prevents charging	Check that the charging equipment is in good condition and properly connected. Also, check that the charging station is connected to the mains and is working. Contact the authorized dealer if the fault remains
Red	Flashing	The conditions are not met to start charging the traction batteries	Check the following: <ul style="list-style-type: none"> <li>• Parking brake is applied</li> <li>• Chassis switch is in the On position</li> <li>• Truck is stationary</li> </ul>

## Accident While Charging

If the vehicle is involved in an accident while charging:

- Unlock the cab.
- Press the charging stop button and wait for steady yellow light.
- Once the yellow light goes off, pull the charging plug from the charging inlet.
- If the charging plug cannot be pulled out, perform the procedure given in “Manually retracting the locking pin” section.

## Manually retracting the locking pin

If the locking pin does not retract automatically when the stop button is pressed, then manually retract the lock pin.

### **WARNING**

Risk of arc flash. Position the chassis switch in OFF position before manually retracting the locking pin.

- 1 Open the cap (1) and position the chassis switch (2) to Off position.

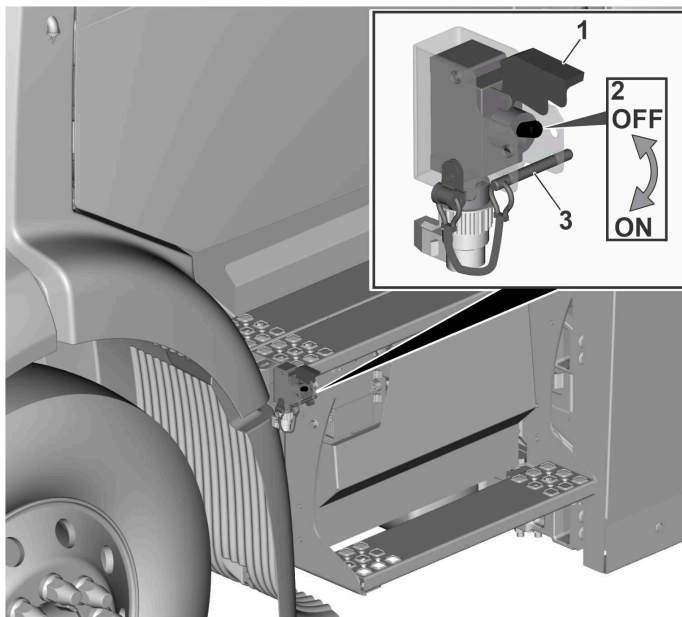

T3166323

- 2 Pull the locking pin (3) from the lower hole of bracket and insert it into upper hole of the bracket.

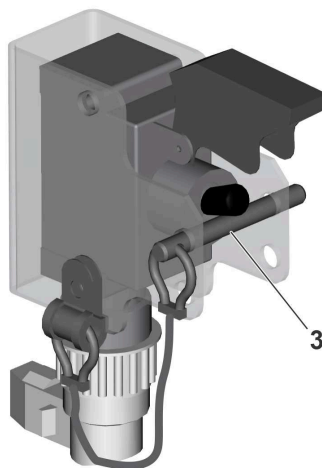

T3169687

3 Remove the screws and remove the step.

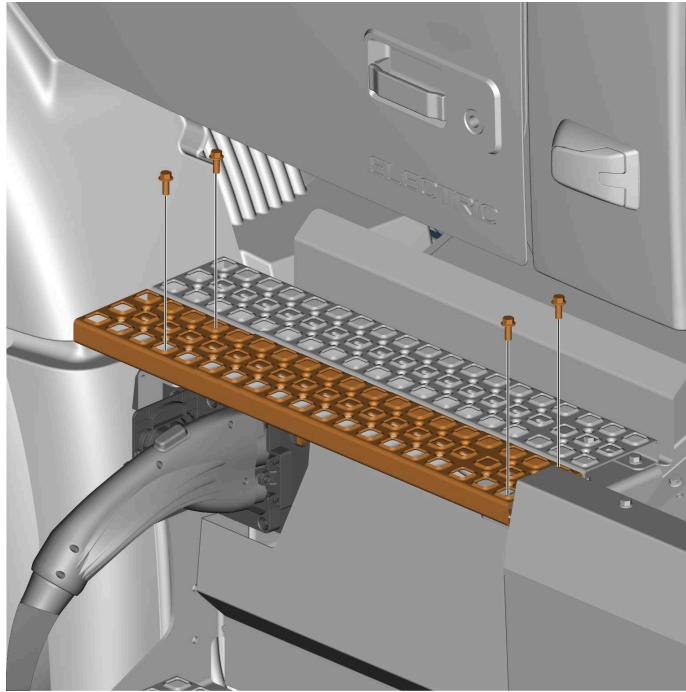

T3166317

4 Rotate the lever and remove the charging plug.



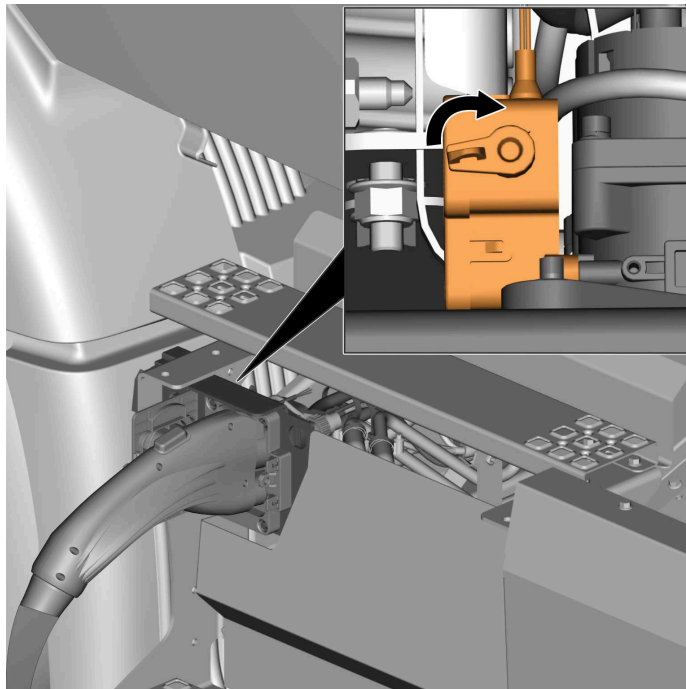

Charging interface CCS1



T3166318



# Parking recommendation

Description	Action when parking	Action when start
Parking the truck less than eight hours	<p>Check the SOC (SOC must be a minimum of 50%). If the SOC is less than the minimum, charge the traction batteries to 50% and disconnect the charger from the truck before parking. Do not disconnect the 24 V system batteries. Do not turn off the chassis switch.</p> <p><b>or</b></p> <p>Connect the charger to the truck during parking. Do not disconnect the 24 V system batteries. Do not turn off the chassis switch.</p>	<p>If the truck is connected to the charger, disconnect the charger.</p> <div data-bbox="1094 422 1534 506" style="border: 1px solid black; padding: 5px;">  <b>CAUTION</b> </div> <div data-bbox="1094 512 1534 615" style="border: 1px solid black; padding: 5px;">           Charge the traction batteries as soon as possible if the SOC warning lamp turns on in the instrument cluster.         </div>
Parking the truck less than two days	<p>Check the SOC (SOC must be a minimum of 75%). If the SOC is less than the minimum, charge the traction batteries to 75% and disconnect the charger from the truck before parking. Do not disconnect the 24 V system batteries. Do not turn off the chassis switch.</p> <p><b>or</b></p> <p>Connect the charger to the truck during parking. Do not disconnect the 24 V system batteries. Do not turn off the chassis switch.</p>	<div data-bbox="1094 636 1534 720" style="border: 1px solid black; padding: 5px;">  <b>WARNING</b> </div> <div data-bbox="1094 726 1534 863" style="border: 1px solid black; padding: 5px;">           Do not start the truck if the SOC warning lamp flashes in the instrument cluster. Charge the traction batteries immediately.         </div>
Parking the truck less than one week	<p><b>Ambient Temperature above -10°C (14°F):</b> Check the SOC (SOC must be 100%). If the SOC is less than the 100%, charge the traction batteries to 100% and disconnect the charger from the truck before parking. Do not disconnect the 24 V system batteries. Do not turn off the chassis switch.</p> <p><b>or</b></p> <p>Connect the charger to the truck during parking. Do not disconnect the 24 V system batteries. Do not turn off the chassis switch.</p>	<p>If the truck is connected to the charger, disconnect the charger</p> <div data-bbox="1094 1119 1534 1203" style="border: 1px solid black; padding: 5px;">  <b>CAUTION</b> </div> <div data-bbox="1094 1209 1534 1312" style="border: 1px solid black; padding: 5px;">           Charge the traction batteries as soon as possible if the SOC warning lamp turns on in the instrument cluster.         </div> <div data-bbox="1094 1333 1534 1417" style="border: 1px solid black; padding: 5px;">  <b>WARNING</b> </div> <div data-bbox="1094 1423 1534 1560" style="border: 1px solid black; padding: 5px;">           Do not start the truck if the SOC warning lamp flashes in the instrument cluster. Charge the traction batteries immediately.         </div>
	<p><b>Ambient Temperature below -10°C (14°F):</b> Check the SOC (SOC must be 100%). If the SOC is less than the 100%, charge the traction batteries to 100% and disconnect the charger from truck before parking. Do not disconnect the 24 V system batteries. Do not turn off the chassis switch. Check the SOC of the traction batteries once in every two</p>	<p><b>To restart the vehicle after a week long parking at ambient temperature of below -10°C (14°F):</b> Charge the vehicle at least for 12 hours before operation. Ensure that the chassis switch is on position.</p>

	<p>days and charge the traction batteries if the SOC is less than 50%.</p> <p><b>Note:</b> Do not connect the charger to the vehicle during parking when the ambient temperature is below -10°C (14°F).</p>	
<p>Parking the truck more than one week</p>	<p>Check the SOC (SOC must be a minimum of 20%). If the SOC is less than the minimum, charge the traction batteries to 20% and disconnect the charger from the truck before parking. Turn off the chassis switch and disconnect the 24 V system batteries. If possible, avoid parking at hot environment.</p>	<p><b>To restart the vehicle after a long parking:</b></p> <ul style="list-style-type: none"> <li>• Connect the 24 V system batteries.</li> <li>• Turn on the chassis switch and charge the vehicle at least for 12 hours before starting.</li> </ul> <p><b>To restart the vehicle after a week long parking at ambient temperature of below -10°C (14°F):</b></p> <ul style="list-style-type: none"> <li>• Connect the 24 V system batteries.</li> <li>• Turn on the chassis switch and charge the vehicle at least for 12 hours before starting.</li> </ul>

**Notes**

---



---



---



---



---



---



---



---



---



---



---



---



---



---



---



---



---



---



---



---



---



---

# Body builder connector (X194)

The body builder connector X194 is inside the dashboard on the ECU electric center. The body builder connector is connected to the vehicle CAN through TGW (Telematics Gateway unit).

Part name	Part number
Body Builder Connector (X194)	8082087

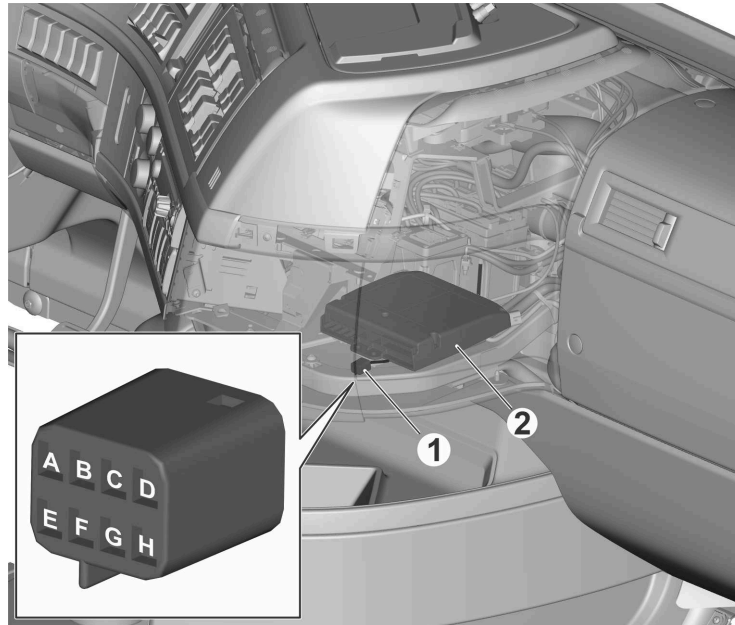

T3168780

- 1 Body Builder Connector (X194)
- 2 TGW (Telematics Gateway) unit

Pin No.	Signal Name	Description	Intended use	Direction (from ECU)
<b>A</b>	D_IN1	Digital Input1	Spare	Input
<b>B</b>	Vehicle CAN2_Low	CANL (J1939)	Vehicle connection and diagnose	Input/output
<b>C</b>	Vehicle CAN2_High Strap	CANH (J1939)	Vehicle connection and diagnose	Input/output
<b>D</b>	Assistance button	Digital input, assistance request button, active low	Emergency assistance call	Input
<b>E</b>	Assistance button	Digital output (source), assistance request feedback light (on button)	Emergency assistance call feedback to driver	Output
<b>F</b>	D_out1	Digital output (sink)	Spare	Output
<b>G</b>	Info_IF	Serial input digital/analogue tachograph	Driver Activity	Input
<b>H</b>	Not Used	—	—	—

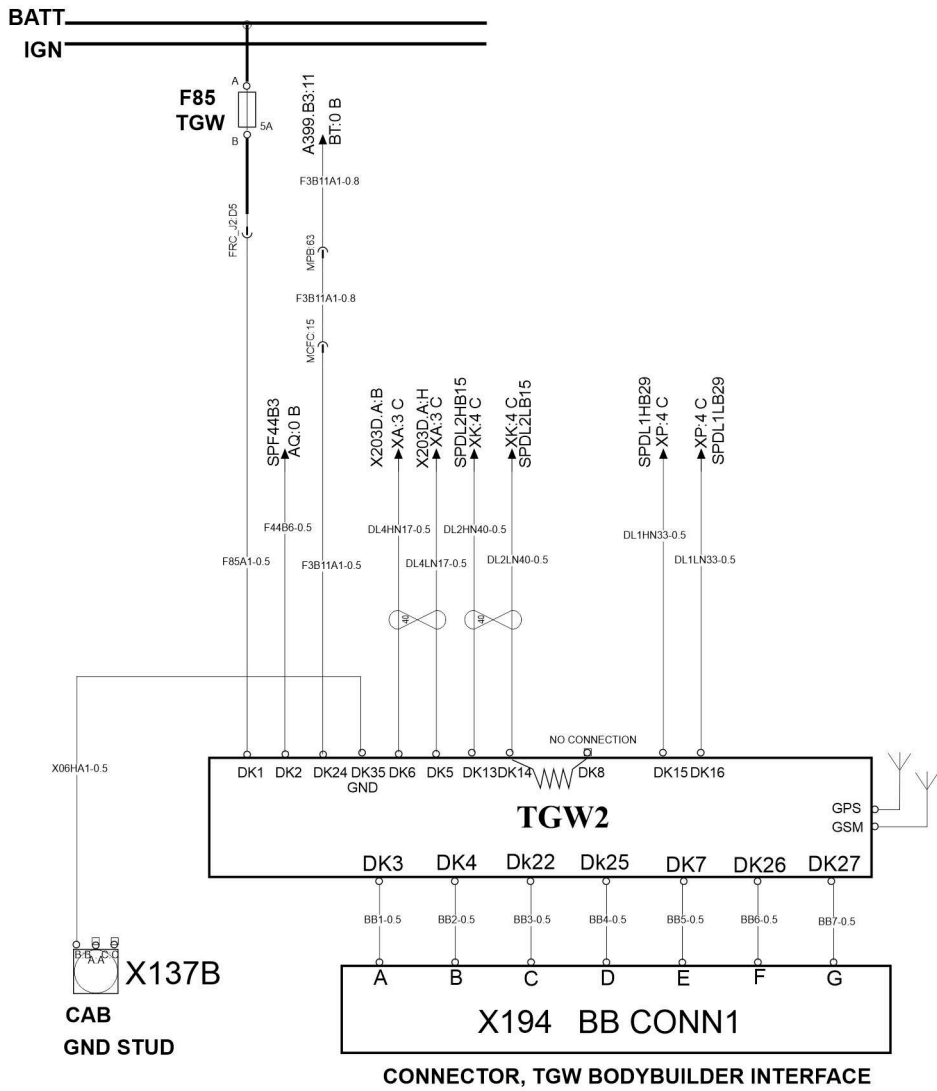

T3168781

# Vehicle Accessory Connector (RP1226)

A TMP RP1226 Connector is located under the dashboard and can be connected to aftermarket Fleet Management devices. Examples of these include telematics devices, data logging equipment, tire pressure monitors and electronic logging devices (ELDs) used for hours-of-service recording.

Part name	Part number
Vehicle Accessory Connector (RP1226)	20734993

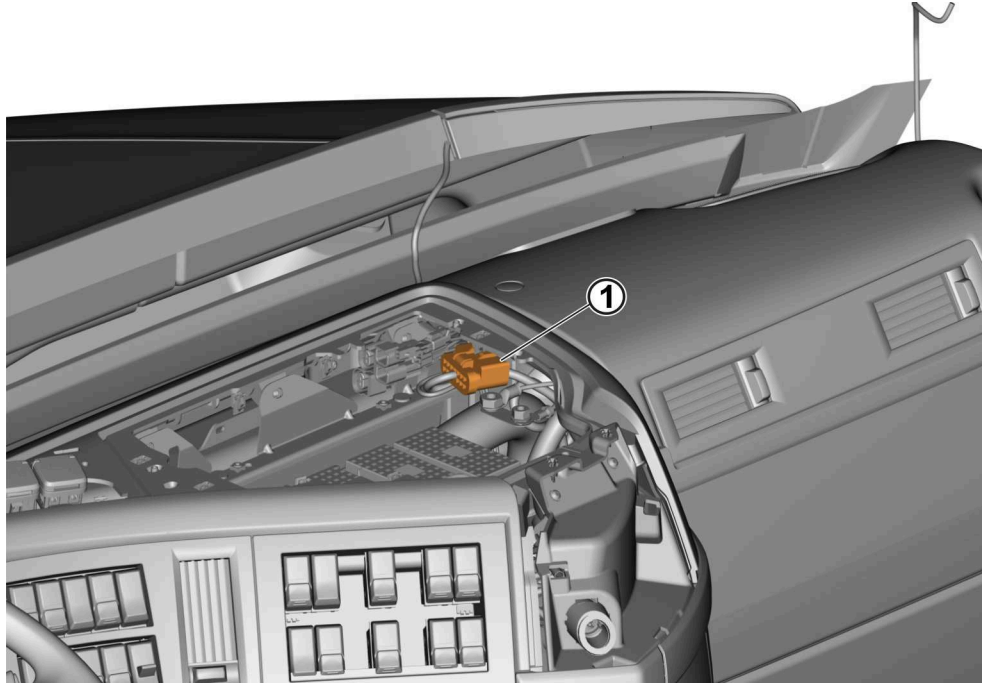

T0169408

1 Vehicle Accessory Connector (RP1226)

# TMC RP1226 Connector

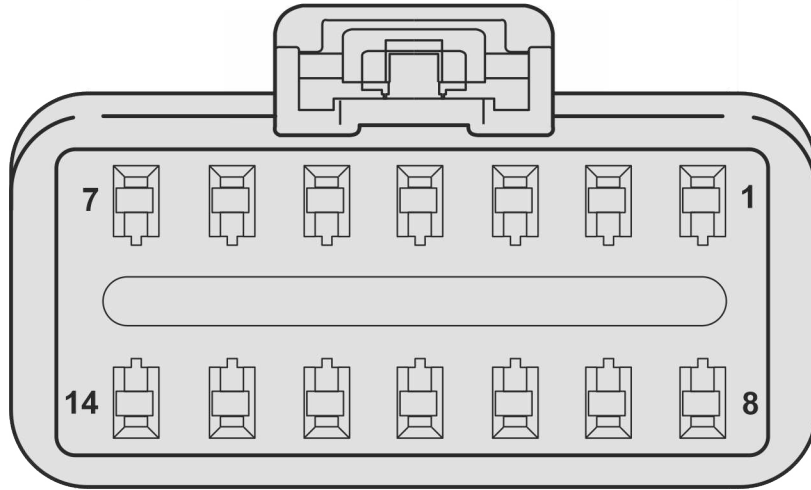

T3159520

Pin numbers	Description
1	+12 V After battery switch (10 A shared)
2	CAN-1 High
3	—
4	—
5	—
6	J1708A
7	+12 V After ignition (10 A shared)
8	Ground
9	CAN-1 Low
10	—
11	—
12	—
13	J1708B
14	+12 V Battery (10 A shared)

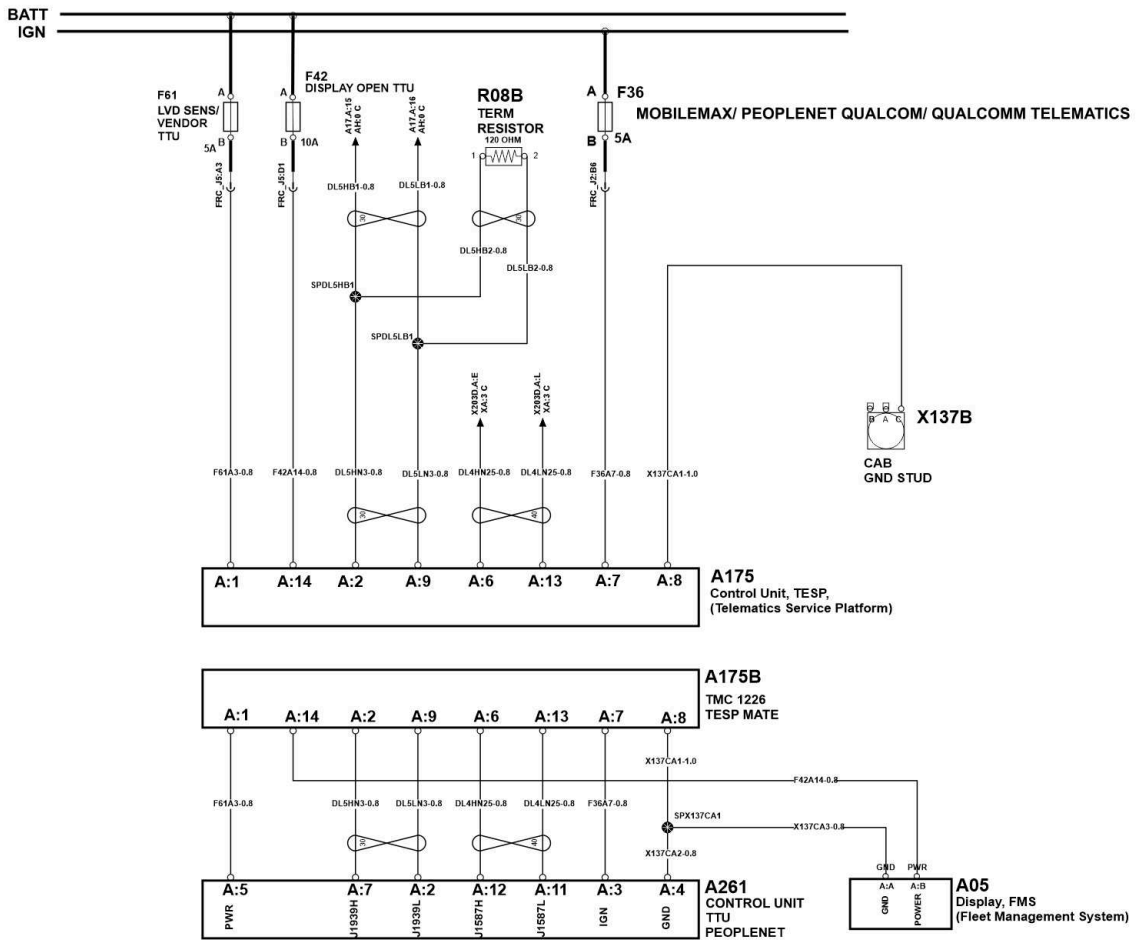

T3169445

**Notes**

---



---



---



---



---



---



---



---

## Fuse and relay box

### **WARNING**

Always use fuses with the correct rating when changing. Never overfuse.

The fuses are designed to protect the electrical system circuits from overload and are usually only tripped as a result of a short circuit. For this reason, if a fuse has blown, always have an authorized Volvo Dealer determine the cause.

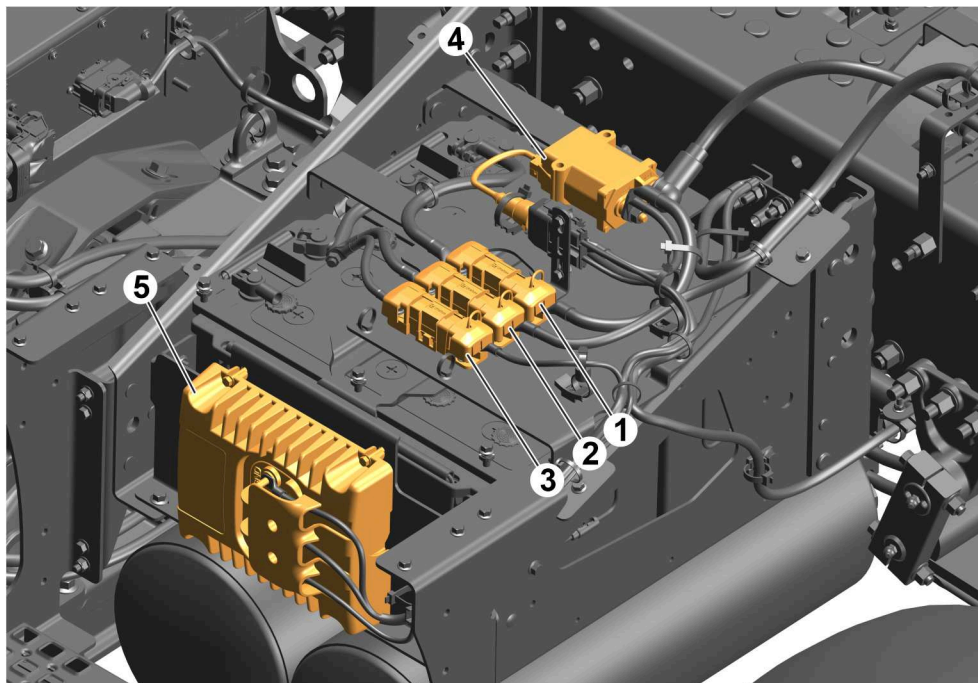

T3180755

- 1 Fuse 24 V main (FH1 - 500 A)
- 2 Fuse (FEM01)
- 3 Equalizer fuse (FH3)
- 4 Main switch (24 V system batteries)
- 5 Battery Equalizer

## Fuse box

### Fuse box (FM-20 & FM-21)

The fuse box is an enclosed structure that contains fuses to protect the electric components from damage due to short circuit and overload. Fuse boxes FM-20 and FM-21 are located on the Modular Power Box (MPB).

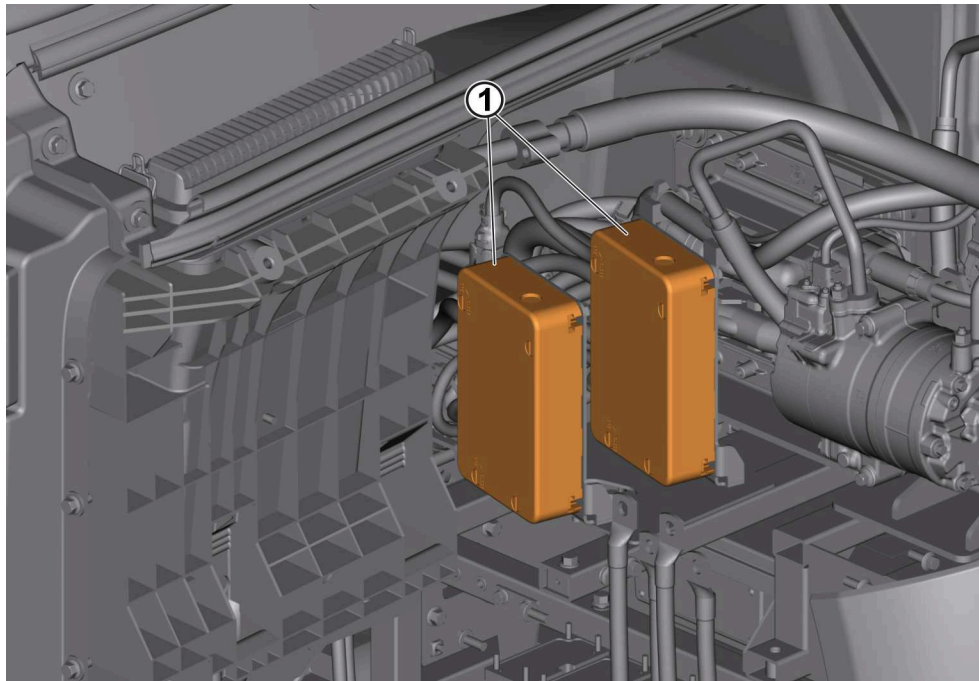

T3169903

1- Fuse boxes (FM-20 & FM-21)

## Layout (Fuse box FM-20)

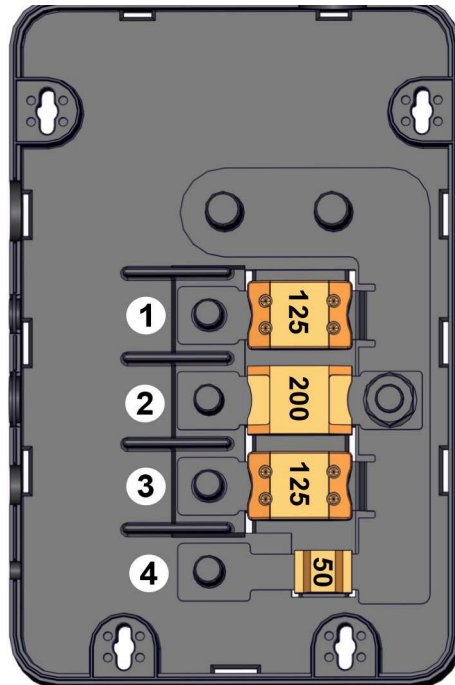

T3171089

### Fuse positions

Positon	Voltage	Rated current	Function
1	24	Fuse 125 A	Heater 1
2	24	Fuse 200 A	Not used
3	24	Fuse 125 A	Heater 2
4	24	Fuse 50 A	Climate

### Notes

---



---



---



---



---

**Layout (Fuse box FM-21)**

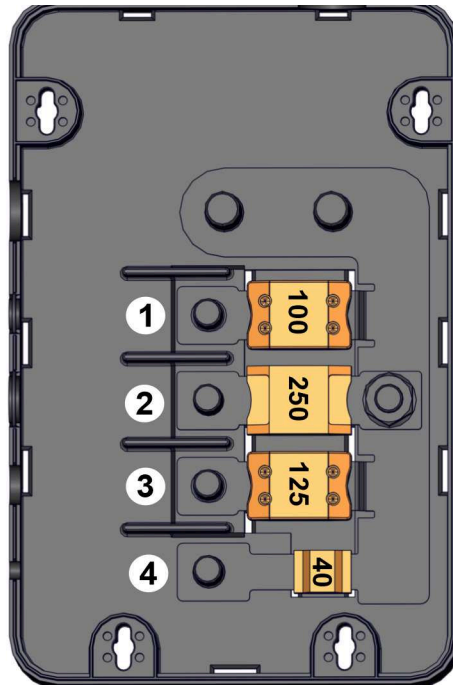

T3179787

**Fuse positions**

Positon	Rated current	Function
1	Fuse 100 A	Main Cab
2	Fuse 250 A	EHPS 2
3	Fuse 125 A	Heater 3
4	Fuse 40 A	Windshield Heater

*Notes*

---



---



---



---



---

## Main fuse box (FM-22)

This main fuse box is located under the hood toward the driver side of the truck, and near the fuse panel (EFRC). The main fuse amperage is 150. Normally, the main fuse lasts for the lifetime of the vehicle. If the fuse blow then the truck must be taken to an authorized Volvo Dealer for inspection of the electrical system.

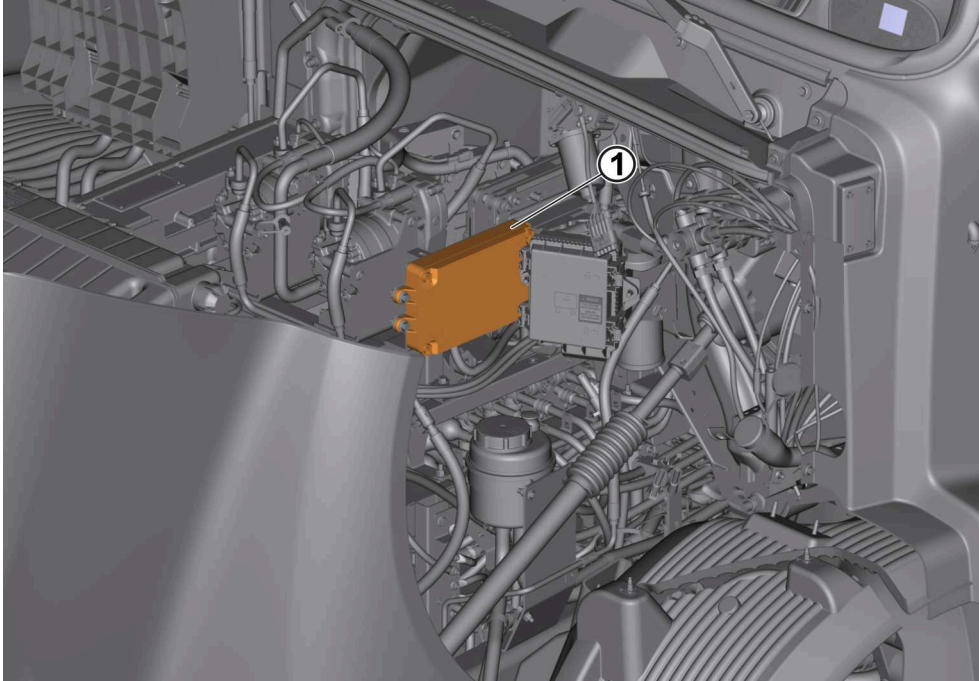

T3169902

1- Main fuse box

## Notes

---

---

---

---

---

---

---

---

## Layout (Fuse box FM-22)

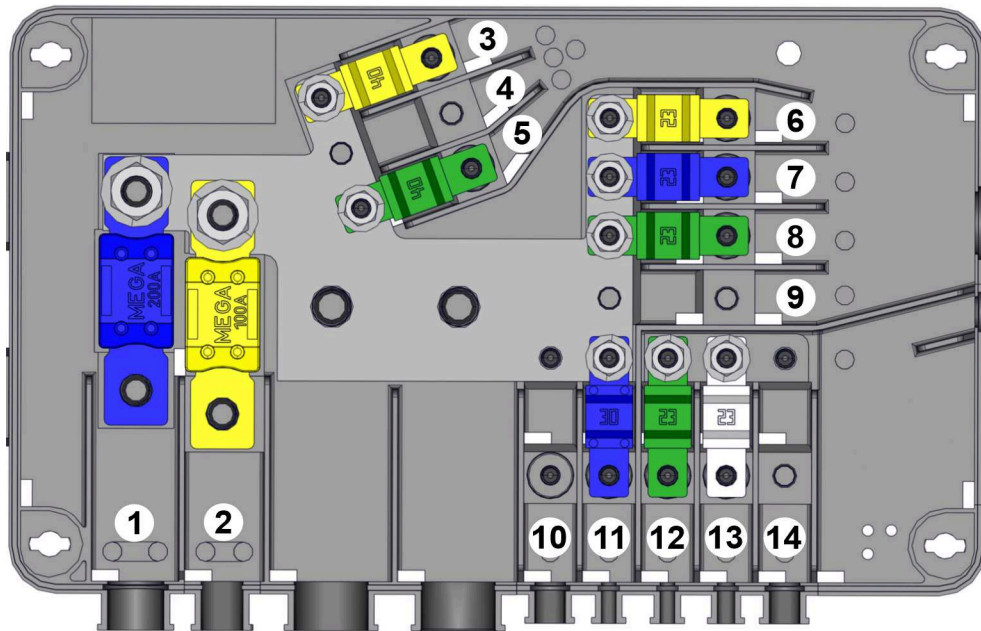

T3169907

### Fuse positions

Position	Voltage	Rated current	Functions
1	24	Mega fuse 250 A	EHPS 1
2	24	Mega fuse 125 A	Heater 4
3	24	Fuse 40 A	Fan 1
4	24	Fuse 40 A	Fan 2
5	24	Fuse 40 A	Fan 3
6	24	Fuse 40 A	Fan 4
7	24	Fuse 30 A	ECEC Main Switch
8	24	Fuse 30 A	ECEC Main Switch
9	24	Fuse 30 A	ECEC Main Switch
10	24	Fuse 100 A	Main Cab
11	24	Fuse 23 A	Oil pump
12	24	Fuse 23 A	Aux Cab
13	24	Fuse 40 A	Not used
14	24	Fuse 50 A	Not used

## Fuse box (FM-23)

The fuse box is an enclosed structure that contains fuse to protect the electric components from damage due to short circuit and overload. Fuse box FM-23 is located on the 24 V system batteries.

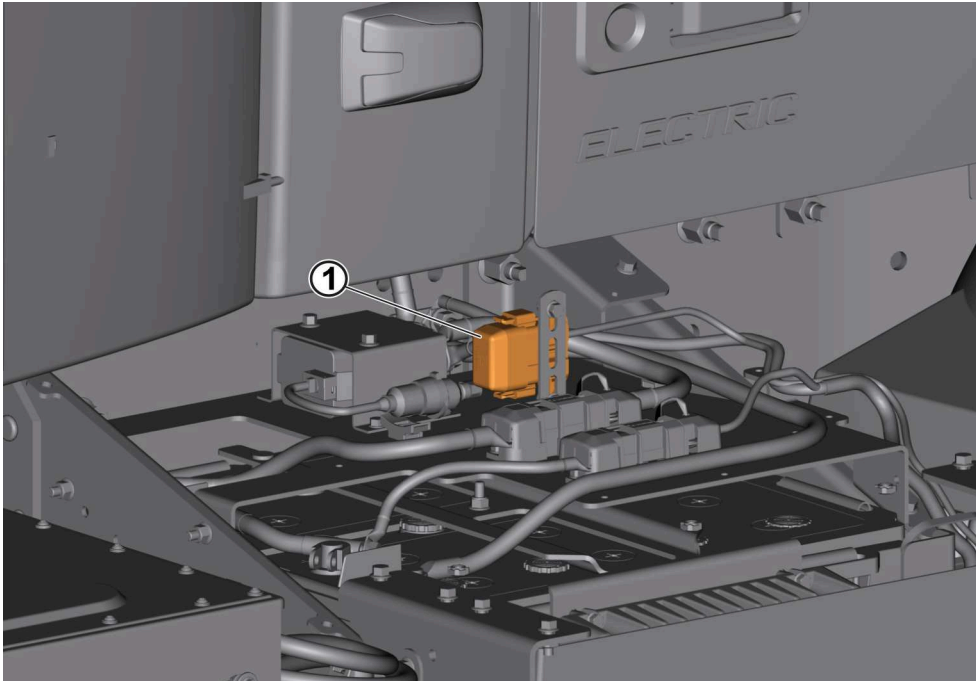

T3169904

1– Fuse box FM-23

## Layout (Fuse box FM-23)

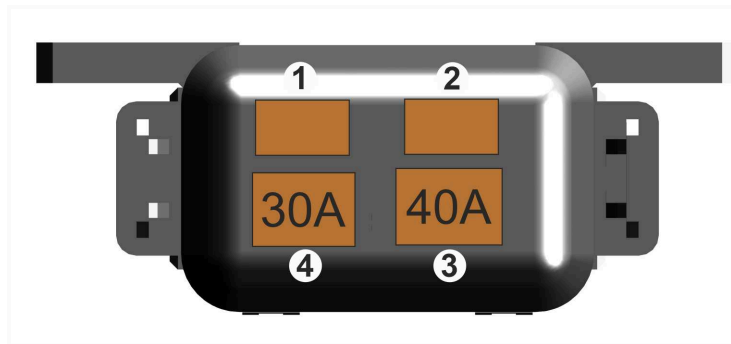

T3181694

Fuse box FM-23

## Fuse positions

Position	Rated current	Functions
1	Fuse	Not used
2	Fuse	Not used
3	Fuse 40 A	EPMU
4	Fuse 30 A	Fuse and Relay center

## Fuse and relay center (chassis)

Fuse and relay center (chassis) is located on the right-hand side of the Modular Power Box (MPB). It acts as an electrical hub and contains all fuses and relays connected to the different electrical and electronic components.

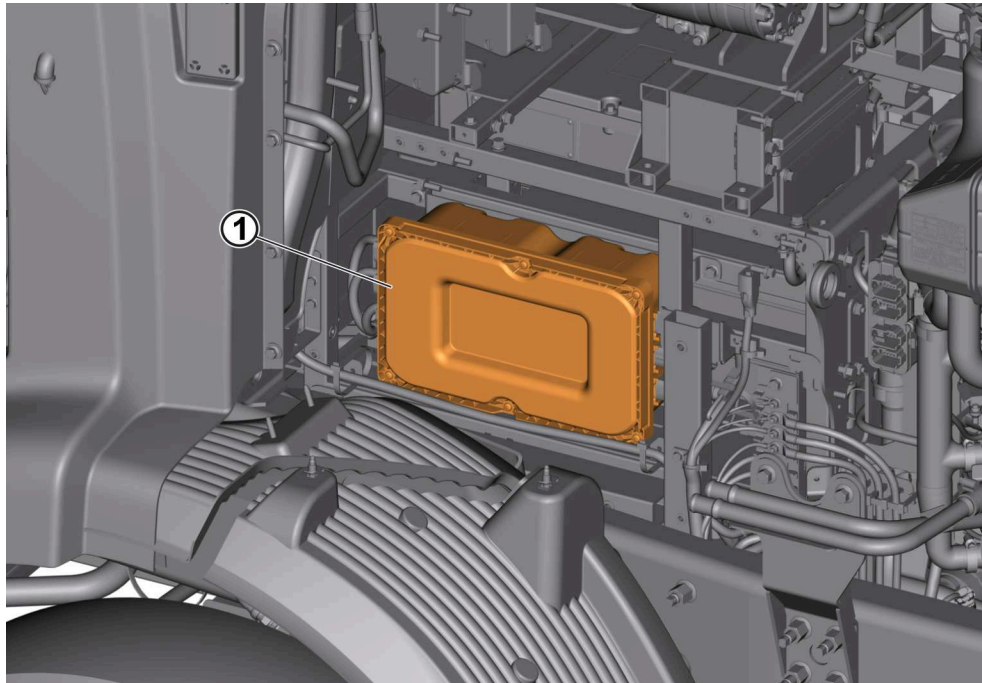

T3169905

1-Fuse and relay center

### Notes

---

---

---

---

---

---

---

---

# Fuse and relay center Layout (chassis)

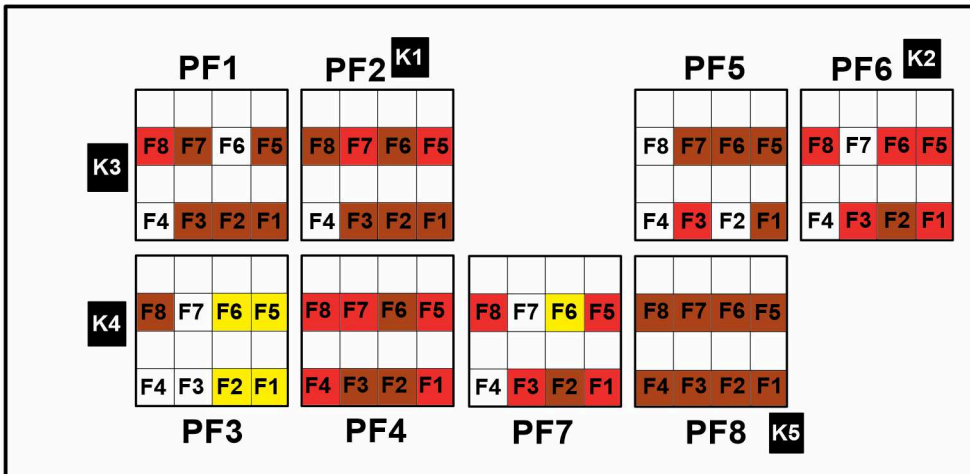
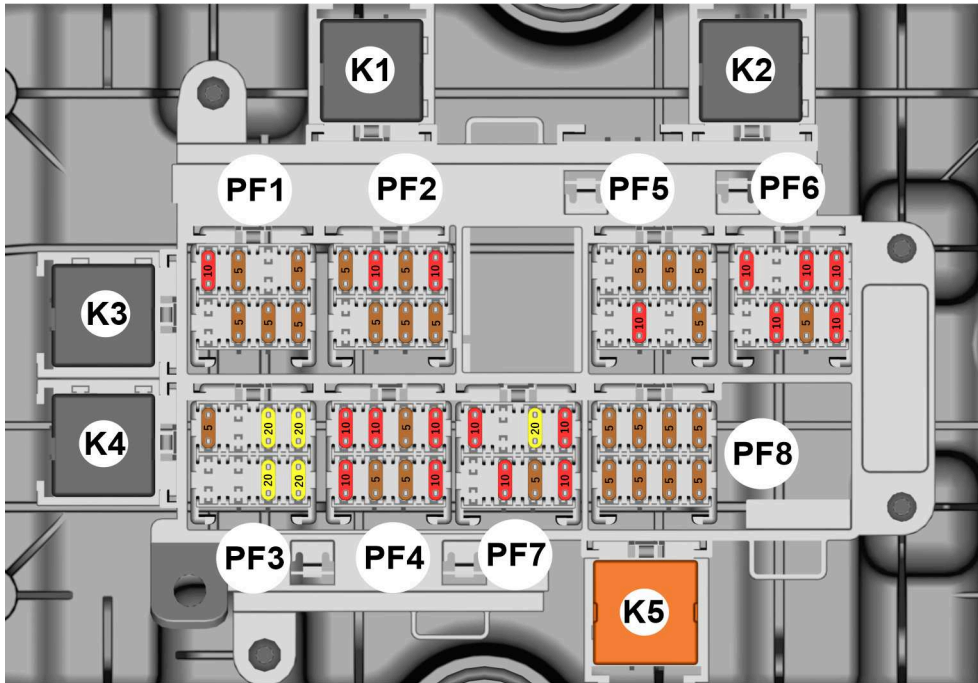

T3169906

**Fuse and relay center, chassis fuse positions**

Module	Position	Rated current	Function
PF1	F1	5 A	Supply, Main 24 V
	F2	5 A	Enable, 15C K2
	F3	5 A	Supply, Main 24 V
	F4		
	F5	5 A	Supply, Main 24 V
	F6		Supply, K5 (IDEM main)
	F7	5 A	Enable, 15C K2
	F8	10 A	Supply, K5 (IDEM main)
PF2	F1	5 A	Supply, Main 24 V
	F2	5 A	Enable, 15C K2
	F3	5 A	Supply, Main 24 V
	F4		
	F5	10 A	Supply, Main 24 V
	F6	5 A	Enable, 15C K2
	F7	10 A	Supply, K5 (IDEM main)
	F8	5 A	Measure, Direct 24 V
PF3	F1	20 A	Supply, Main 24 V
	F2	20 A	Supply, Main 24 V
	F3		
	F4		
	F5	20 A	Supply, Main 24 V
	F6	20 A	Supply, Main 24 V
	F7		
	F8	5 A	Enable, 15C K2
PF4	F1	10 A	Supply, Main 24 V
	F2	5 A	Enable, 15C K2
	F3	5 A	Enable, 15C K2, TGW
	F4	10 A	24 V Direct Supply for BB
	F5	10 A	Supply, Direct 24 V
	F6	5 A	Supply, Direct 24 V
	F7	10 A	Supply, K3
	F8	10 A	Supply, K4
PF5	F1	5 A	Enable, 15 K1
	F2		Enable, 15 K1
	F3	10 A	Supply, K1
	F4		Enable, K1

	F5	5 A	Enable, K1
	F6	5 A	Supply, Direct 24 V
	F7	5 A	Enable, 15C K2
	F8		Supply, Direct 24 V
PF6	F1	10 A	Enable, 15C K2
	F2		Supply, Direct 24 V
	F3	10 A	Enable, 15C K2
	F4	10 A	Supply, Direct 24 V
	F5		Enable, 15C K2
	F6	10 A	New
	F7	5 A	New
	F8	10 A	New
PF7	F1	10 A	Supply, Direct 24 V
	F2	5 A	Enable, 15C K2
	F3	10 A	Supply, Direct 24 V
	F4		Enable, 15C K2
	F5	10 A	Supply, Direct 24 V
	F6	20 A	Supply, Main 24 V
	F7		Supply, Main 24 V
	F8	10 A	Enable, 15C K2
PF8	F1	5 A	Supply, Main 24 V
	F2	5 A	Enable, 15C K2
	F3	5 A	Supply, Main 24 V
	F4	5 A	Enable, 15C K2
	F5	5 A	Supply, Main 24 V
	F6	5 A	Enable, 15C K2
	F7	5 A	Supply, Main 24 V
	F8	5 A	Enable, 15C K2

### Relays

Position	Rated current	Function
K1	20 A	Ignition Power
15CK2	20 A	Plug key power
K3	20 A	EVCM power relay
K4	20 A	Oil Thermostat drive
K5	40 A	ESCM power relay

## External Fuse and Relay Center (EFRC)

ERFC is located under the hood toward the driver side of the truck. The fuse and relay locations are etched into the inside cover. Normally the fuses and relays last for the truck entire service life without blowing. If a fuse does blow then the truck must be taken to an authorized Volvo Dealer for inspection of the electrical system.

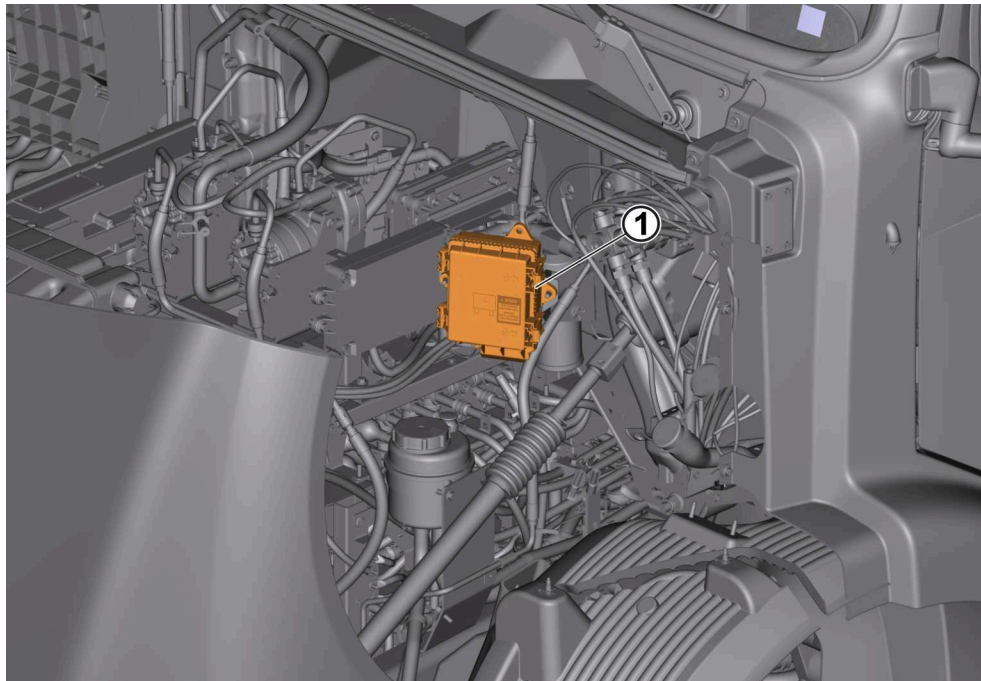

T3169911

1– External Fuse and Relay Center (EFRC)

### Notes

---

---

---

---

---

---

---

---

# EFRC Layout

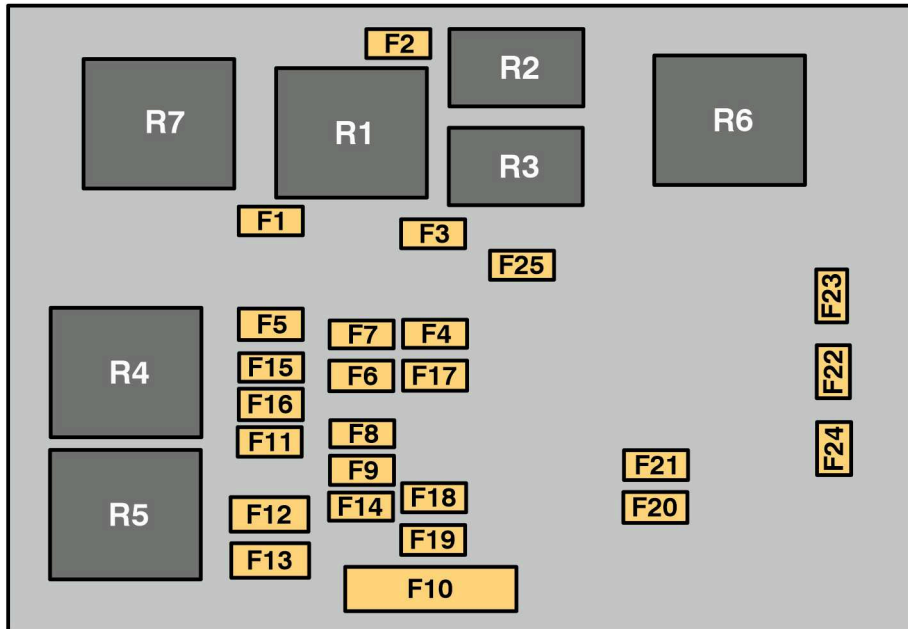
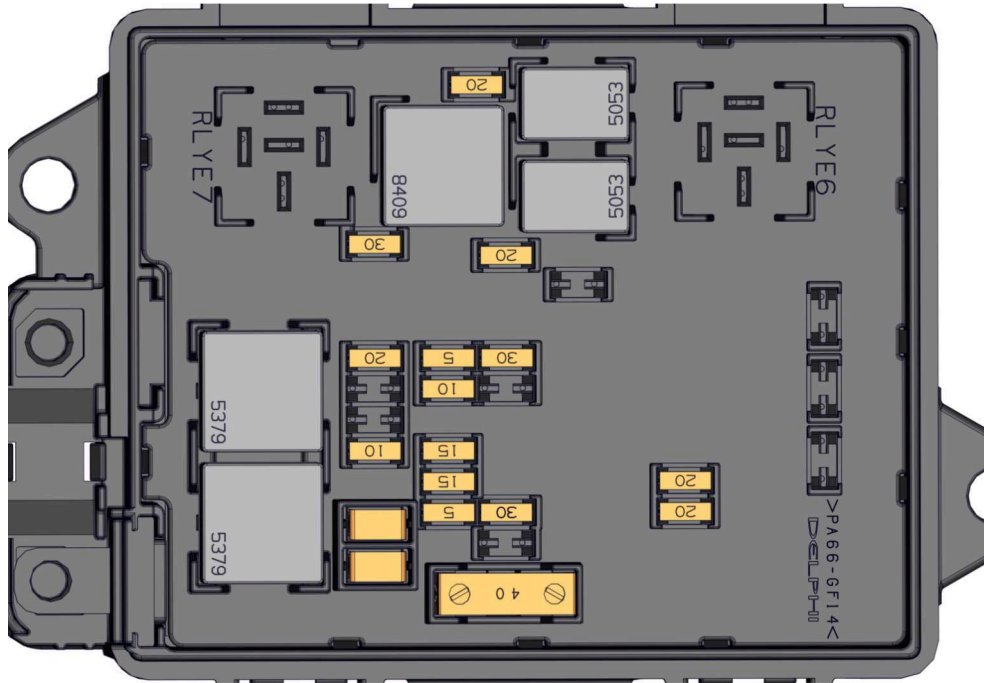

T3169908

External Fuse and Relay Center (EFRC)

## EFRC Fuse & Relay positions

Position	Rated current	Function
F1	30 A	Trailer stop lamps
F2	20 A	Trailer clearance lamps
F3	20 A	Trailer marker lamps
F4	30 A	Spare
F5	20 A	Spare
F6	10 A	VECU
F7	5 A	Spare
F8	15 A	Spare
F9	15 A	Spare
F10	40 A	Trailer Auxiliary
F11	10 A	ABS
F12	20 A	Spare
F13	15 A	Air dryer
F14	5 A	TPM
F15	10 A	Spare
F16	10 A	Spare
F17	20 A	Spare
F18	30 A	Spare
F18	20 A	Spare
F19	15 A	Auto transmission
F20	20 A	Trailer turn L
F21	20 A	Trailer turn R
F22	30 A	Spare
F23	30 A	Spare
F24	30 A	Spare
F25	30 A	-
R1	-	Trailer stop lamps
R2	-	Trailer clearance lamps
R3	-	Trailer marker lamps
R4	-	Spare
R5	-	Start power
R6	-	Spare
R7	-	Spare

## Fuses and Relays Center (FRC) Instrument Panel



### WARNING

#### Risk of component damage

Always use fuses with the correct rating when changing. Never overfuse.

**Note:** If possible set the electrical component in the "Off" position, before changing the fuse. The fuse holder can be burned if the voltage remains switched on.

The fuses and relays are under the cover in the center of the instrument panel.

There are decals under the cover, which show the location of fuses and relays and what they are used for.

The exterior lighting is controlled by control units. These include control functions for each respective lighting circuit. Should a circuit be broken, due to overload or short circuit for example, then you will be notified with a message on the instrument cluster. The function is reset when the fault has been corrected.

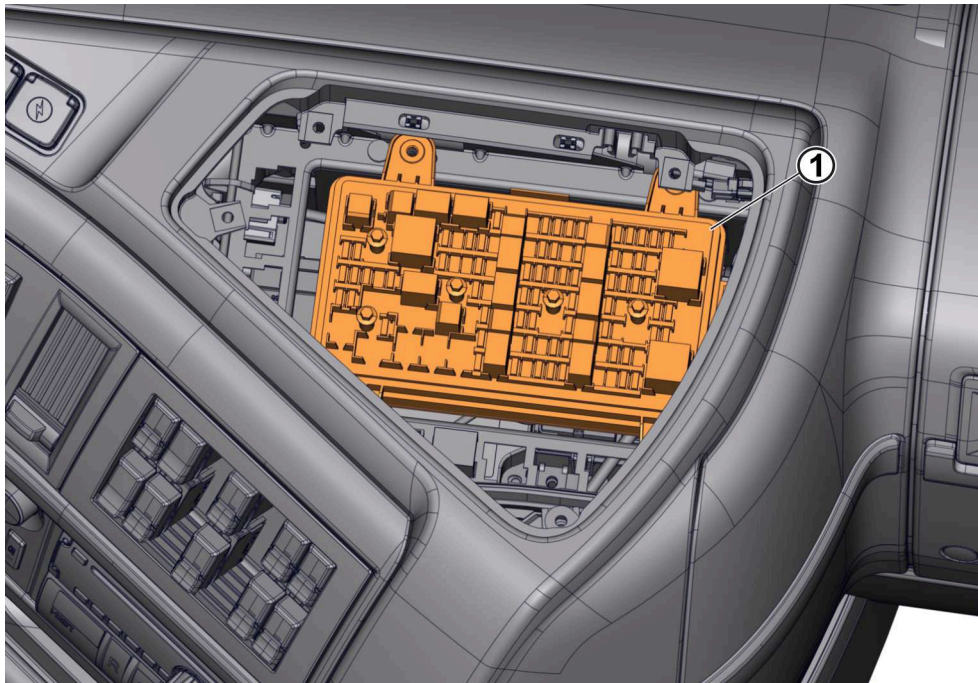

T3169901

1– Fuses and Relays Center (FRC)

## FRC Layout

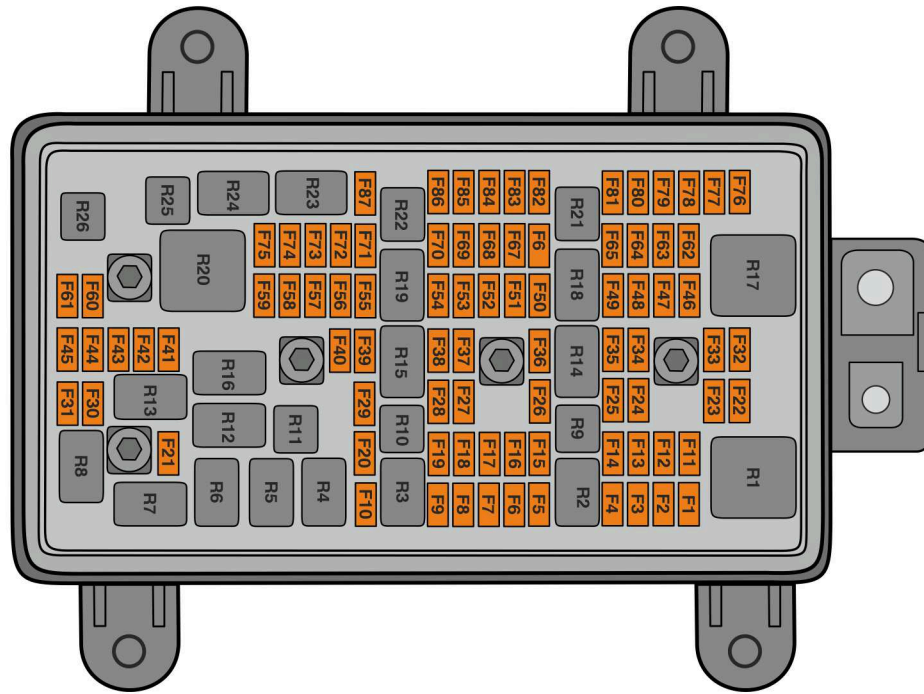

T3169910

## Fuses

Position	Voltage	Rated current	Function
F1	24 V	20 A	RH window/Mirrors
F2	24 V	10 A	HVAC
F3	24 V	20 A	Driver heated seat/Cooler
F3	24 V	25 A	Driver 7-pass heated seats
F4	24 V	10 A	Radio
F4	24 V	25 A	Radio with amplifier
F5	24 V	30 A	Open
F6	24 V	20 A	RH sleeper power ports
F7	24 V	20 A	LH sleeper power ports
F8	24 V	15 A	Auxiliary switches 1
F8	24 V	30 A	Auxiliary switches 2
F9	24 V	10 A	USB charge ports
F10	24 V	10 A	Customer LVD2
F11	24 V	10 A	Open
F12	24 V	20 A	Dashboard power ports
F13	24 V	20 A	LH window/Mirrors
F14	24 V	10 A	Open
F15	24 V	30 A	Open
F16	24 V	20 A	Overhead socket

F17	24 V	15 A	Auxiliary switches 3
F17	24 V	30 A	Auxiliary switch 3 & 4
F18	24 V	30 A	HVAC fan
F19	24 V	10 A	Roof sign
F19	24 V	30 A	Open
F20	24 V	10 A	Horn
F21	24 V	5 A	Qualcom
F22	24 V	20 A	CB power studs
F23	24 V	10 A	Customer IGN3
F24	24 V	30 A	Open
F25	24 V	5 A	Open
F26	24 V	10 A	Dome/Door interior lamps
F27	24 V	20 A	Open
F28	24 V	10 A	Customer LVD1
F29	24 V	5 A	EFRC
F30	24 V	5 A	Open
F31	24 V	5 A	Open
F32	24 V	15 A	Customer IGN1
F33	24 V	10 A	Air solenoid/switch
F34	24 V	10 A	Open
F35	24 V	15 A	BB IGN-X
F36	24 V	5 A	Telematics
F37	24 V	5 A	Open
F38	24 V	5 A	Aux AC
F39	24 V	10 A	Volvo Dynamic Steering
F40	24 V	5 A	Light control module (LCM)
F41	24 V	30 A	ABS
F42	24 V	10 A	Telematics trans unit display/RP1226
F43	24 V	15 A	Open
F44	24 V	20 A	Key switch
F45	24 V	5 A	Open
F46	24 V	15 A	BBI IGN-Z/Camera prep
F47	24 V	15 A	BB IGN-Y
F48	24 V	10 A	Heated windshield
F49	24 V	15 A	Reverse lamps/Lift axles
F50	24 V	20 A	Open
F51	24 V	10 A	GECU
F52	24 V	10 A	Instrument Cluster

F53	24 V	5 A	Open
F54	24 V	10 A	Transmission
F55	24 V	10 A	Open
F56	24 V	10 A	Bendix fusion lane departure
F57	24 V	15 A	Snow plow lamps LH
F58	24 V	15 A	Snow plow lamps RH
F59	24 V	10 A	Seat SRS
F60	24 V	30 A	HVAC blower
F61	24 V	5 A	LVD sensor/Vendor telematics
F62	24 V	10 A	Open
F63	24 V	10 A	Customer (Ignition 2 Bus)
F64	24 V	15 A	Open
F65	24 V	5 A	Open
F66	24 V	30 A	Open
F67	24 V	10 A	PCC (Predictive Cruise Control)
F68	24 V	10 A	Radio
F69	24 V	10 A	VECU
F70	24 V	10 A	Open
F71	24 V	10 A	Open
F72	24 V	5 A	SRS
F73	24 V	5 A	ACC/Side sensor/ECS
F74	24 V	10 A	Open/TABS6
F75	24 V	25 A	Wiper
F76	24 V	30 A	Open
F77	24 V	10 A	Bendix fusion
F78	24 V	25 A	LCM2
F79	24 V	25 A	LCM4
F80	24 V	10 A	Diagnostic connector
F81	24 V	20 A	LCM1
F82	24 V	20 A	LCM6
F83	24 V	20 A	LCM5
F84	24 V	15 A	Power door locks
F85	24 V	5 A	Telematic gateway
F86	24 V	10 A	Electronically Controlled Suspension (ECS)
F86	24 V	15 A	Beacon lamp
F87	24 V	15 A	Customer use (Battery 1 BUS)

## Relays

Position	Function
R1	Accessory power
R2	Radio wake
R3	Roof marker
R4	Open/Vendor start enable
R5	Open
R6	Open
R7	Open
R8	Open
R9	Dome/Door lamps
R10	City horn
R11	Start enable
R12	Open/Remote start
R13	Open
R14	Lift axle/Reverse signal
R15	Body builder
R16	Body builder
R17	Power ignition 1 BUS
R18	Transmission power
R19	Open
R20	Start+ BUS
R21	Open
R22	ECS power
R23	Intermittent wiper
R24	Intermittent wiper
R25	Remote throttle DEC
R26	Remote throttle INC

**External relays**

<b>Position</b>	<b>Function</b>
ER1	Open
ER2	Open
ER3	Open
ER4	Open
ER5	Open
ER6	Open
ER6	Open
ER7	Open
ER8	Open
ER9	Open

**Expansion**

<b>Position</b>	<b>Function</b>
F28	Customer LVD1
F10	Customer LVD2
F87	BAT1
F32	Customer IGN1
F63	Customer IGN2
F23	Customer IGN3

**Notes**

---

---

---

---

---

---

---

---

## 24 V Power Supply

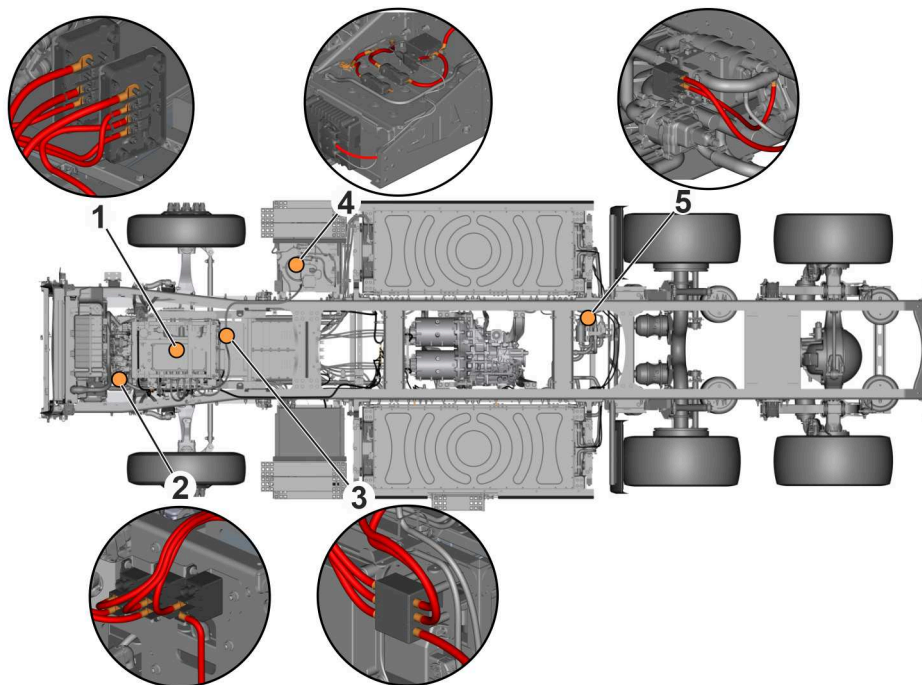

T3169912

- 1 Fuse box
- 2 Heater relay front
- 3 Six way junction box
- 4 24 V system batteries
- 5 Heater relay middle

## 600 V Power locations

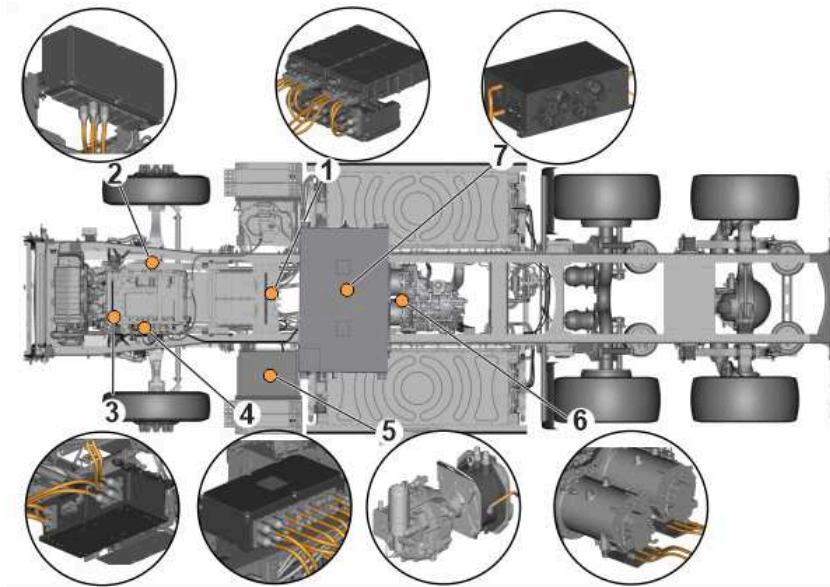

N420371

600v Power location for tractor Vehicles

- 1 Electric Motor Drive (EMD)
- 2 Traction Voltage Junction Box (TVJB) (3 HCC (High-Current Connection) and 4 LCC (Low-Current Connection))
- 3 Charging Switch Unit (CSU)
- 4 TVJB (2 HCC and 5 LCC)
- 5 Electric Motor (EM)
- 6 Electric Vehicle Air Compressor (EVAC)
- 7 Battery Thermal Management System (BTMS)

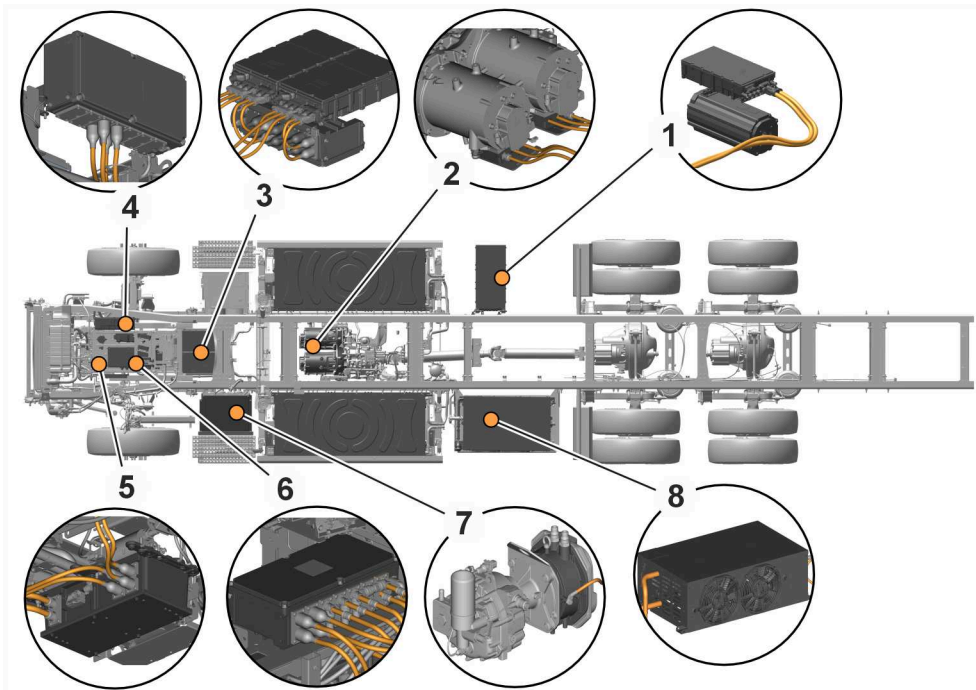

T3213568

600 V Power locations for rigid vehicles

- 1 Electric PTO (ePTO)
- 2 Electric Motor (EM)
- 3 Electric Motor Drive (EMD)
- 4 Traction Voltage Junction Box (TVJB) (3 HCC (High-Current Connection) and 4 LCC (Low-Current Connection))
- 5 Charging Switch Unit (CSU)
- 6 TVJB (2 HCC and 5 LCC)
- 7 Electric Vehicle Air Compressor (EVAC)
- 8 Battery Thermal Management System (BTMS)

**Notes**

---



---



---



---



---



---



---



---

# Ground locations

## 12 V Cab Ground Location

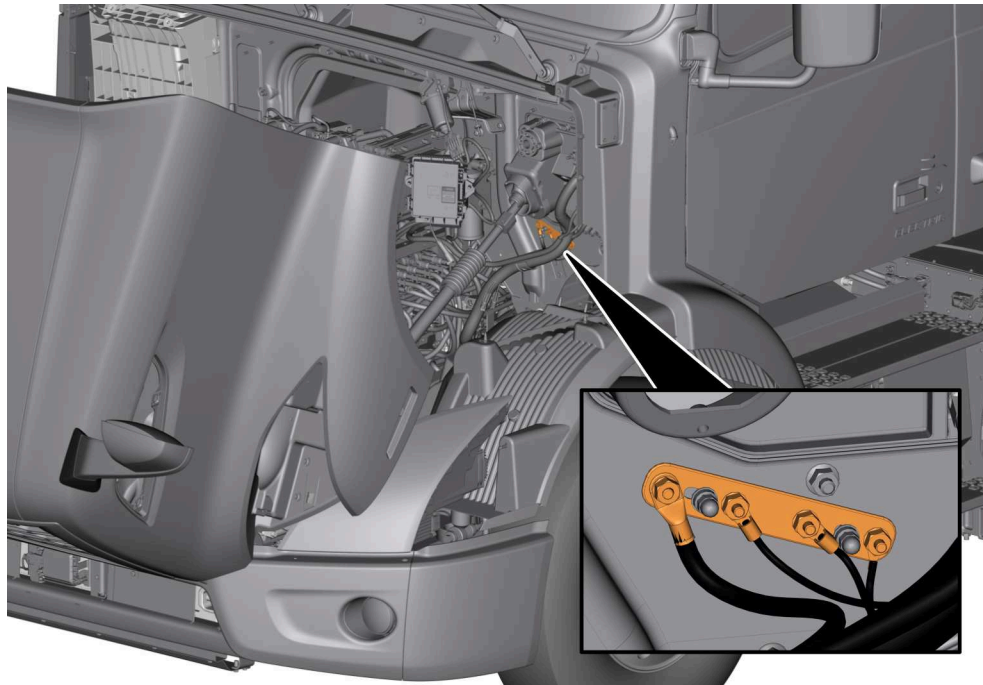

T3166515

### Notes

---

---

---

---

---

---

---

---

## Ground locations on chassis

### 24 V Ground locations

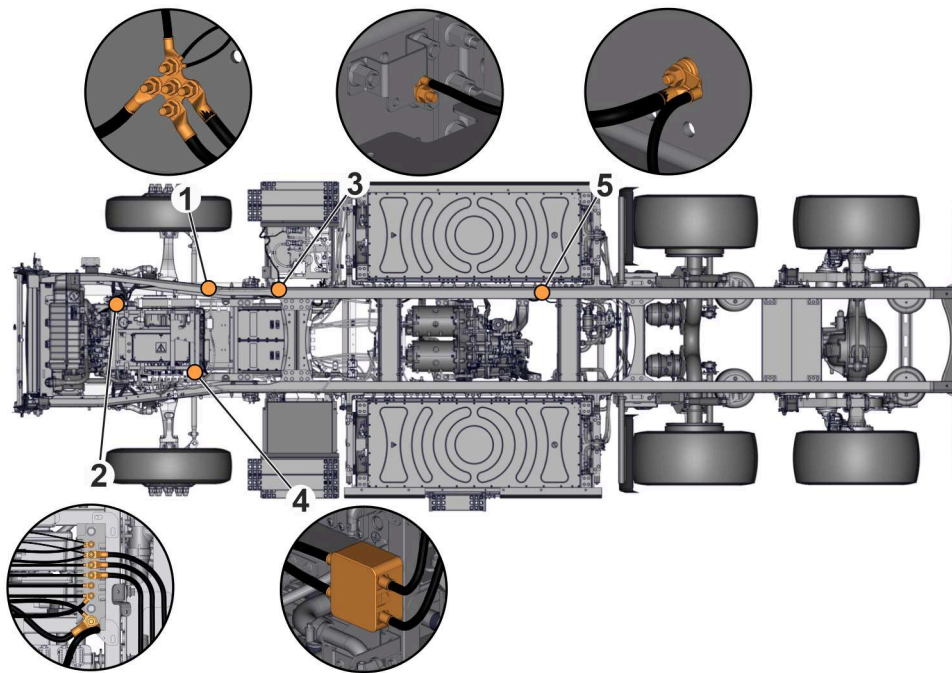

T3166516

- 1 Chassis ground front right (X911)
- 2 Chassis junction front right (X209)
- 3 Chassis ground right (X912)
- 4 Six way junction box (X86)
- 5 Chassis ground mid right (X913)

## 600 V Ground locations

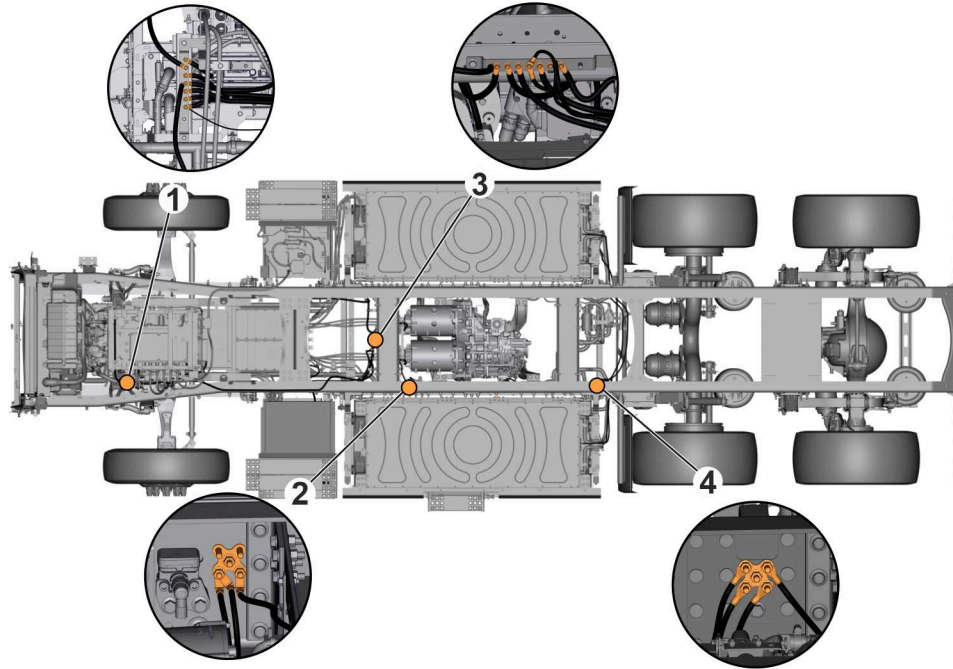

T3166514

- 1 Ground busbar Modular Power Box (MPB) front (X244)
- 2 Ground busbar chassis mid left (X246)
- 3 Ground busbar chassis center (X245)
- 4 Ground chassis rear left (X247)

### Notes

## Connection to chassis frame

The connection to the chassis must be done as shown in the below illustration.

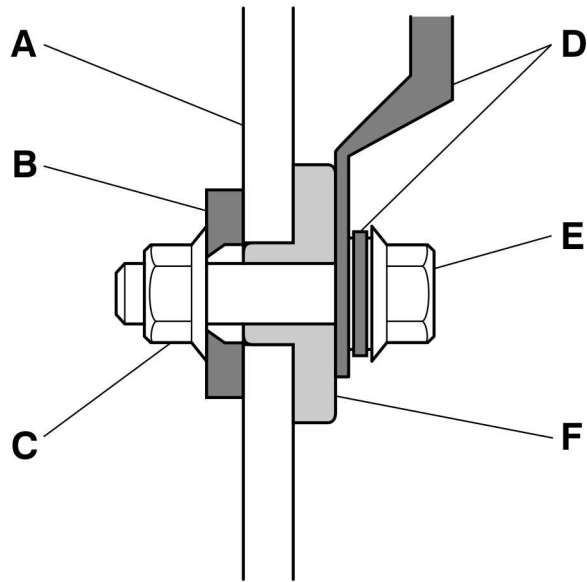

T9008529

**Tightening torque:  $45 \pm 9$  Nm**

- A = Frame rail
- B = Washer, ground connection. Part number: 20704406
- C = Nut, Part number: 990194
- D = Ground terminal (Max 3 at the same ground point)
- E = Bolt, Part number: 991614
- F = Press washer. Part number: 20592579

### Notes

---

---

---

---

---

---

---

---

# Mechanical ePTO

## Overview

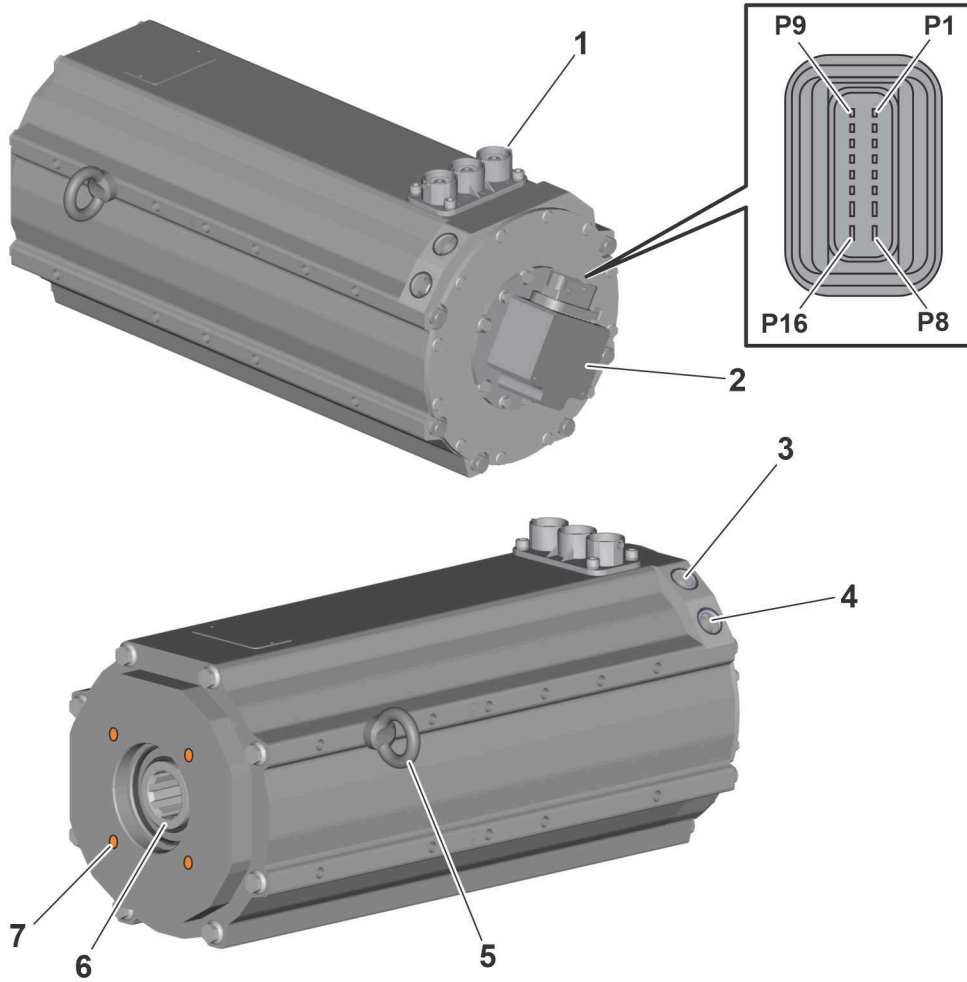

T3173468

1	AC power interface
2	Resolver connector
3	Coolant outlet
4	Coolant inlet
5	Lifting eye
6	Output shaft
7	Mounting screw hole for auxiliary equipment

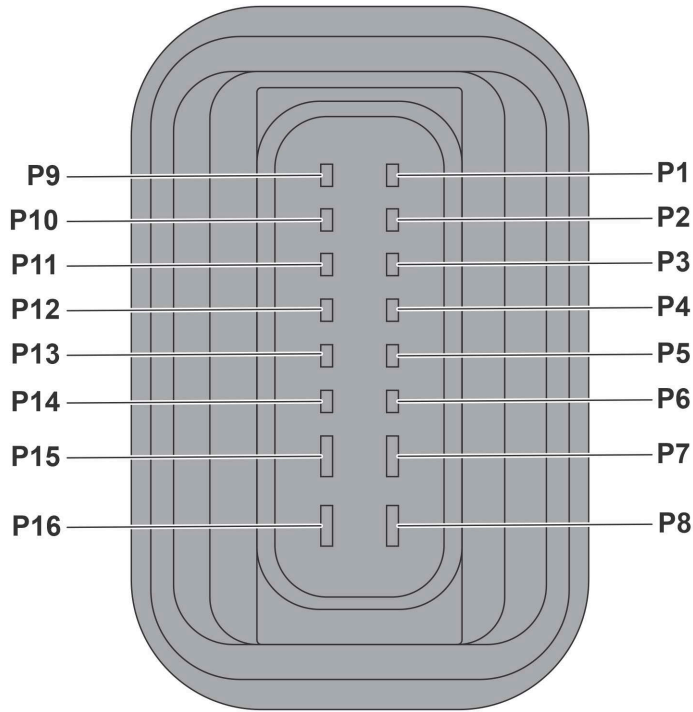

T3174385

Resolver Connector Pin-out			
P1	Sin (-) S2	P9	KTY2 Winding Therm (+)
P2	Sin (+) S4	P10	KTY2 Winding Therm (-)
P3	Ref (+) R1	P11	HVIL in
P4	Ref (-) Ground R1	P12	HVIL out
P5	Cos (-) S1	P13	Shielding ring
P6	Cos (+) S3	P14	Not connected
P7	KTY1 Winding Therm (+)	P15	Not connected
P8	KTY1 Winding Therm (-)	P16	Not connected

In an electric vehicle, the power take-off is an electric motor (Mech. ePTO) that converts the electric power to mechanical power. The electric motor (mech. ePTO), is an AC motor and is water cooled. It operates at 70 kW AC power. It is connected to a hydraulic pump or other auxiliary equipment.

The electric motor (mech. ePTO) receives voltage supply from the traction batteries through TVJB (Traction Voltage Junction Box), and EMD (Electric Motor Drive). The EMD also controls the speed of electric motor (mech. ePTO) and manages the power supply based on different driving condition.

# EMD3

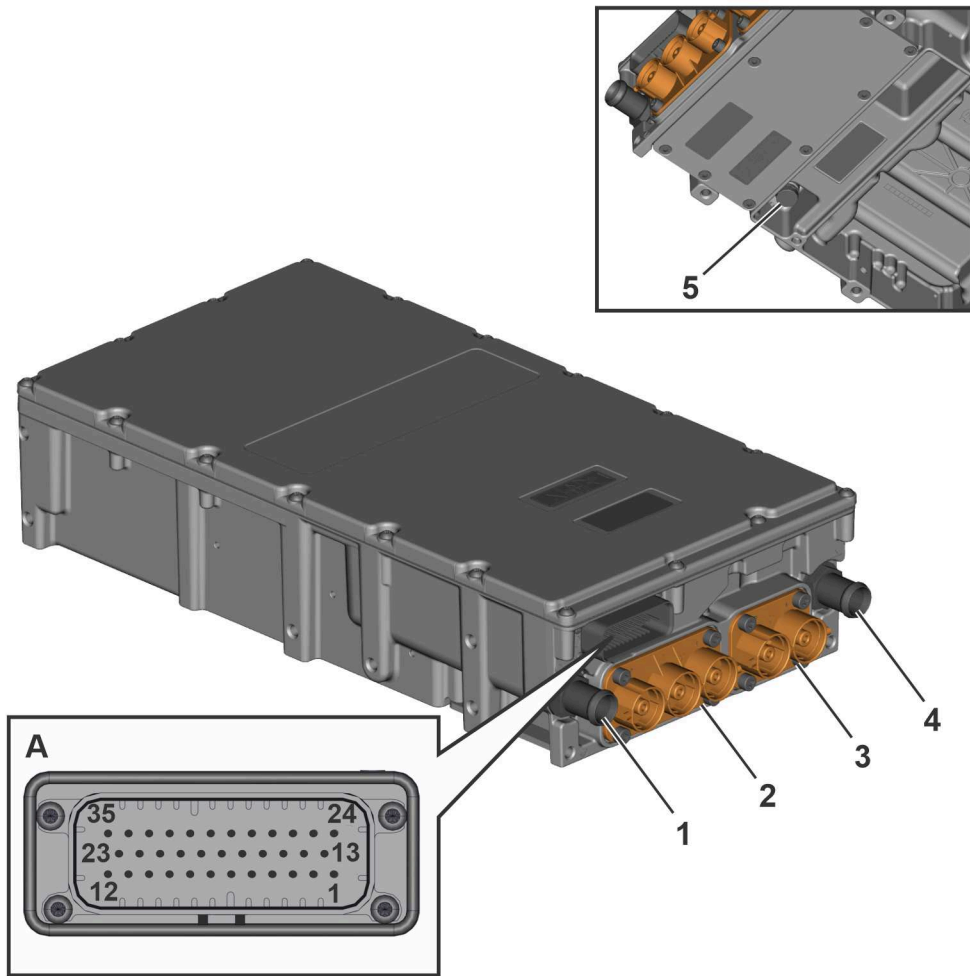

T3173467

1	Coolant outlet
2	AC power interface to Electric Motor (Mech. ePTO)
3	DC power interface to TVJB2 (Traction Voltage Junction Box)
4	Coolant inlet
5	Venting screw
A	EMD connector Interface

Pin number	Signal name	Type	Function description	Pin number	Signal name	Type	Function description
1	ECU supply	Input	12/24 V supply (supply range 8 V – 32 V DC)	19	Resolver REF+	Output	Resolver excitation
2	ECU enable	Input	Wake up signal	20	Resolver SIN+	Input	Resolver interface
3	HVIL IN	Input	HVIL (Current loop)	21	Resolver COS+	Input	Resolver interface
4	HVIL OUT	Output	HVIL (Current loop)	22	Reserved	Not applicable	Reserved (do not connect)
5	Reserved	Not applicable	Reserved (do not connect)	23	Temp+	Input	Electric motor sensor
6	Reserved	Not applicable	Reserved (do not connect)	24	Temp-	Input	Electric motor sensor
7	Resolver REF+	Output	Resolver excitation	25	Reserved	Not applicable	Reserved (do not connect)
8	Resolver SIN+	Input	Resolver interface	26	Reserved	Not applicable	Reserved (do not connect)
9	Resolver COS+	Input	Resolver interface	27	Node ID0	Input	Node ID coding Bit0
10	Reserved	Not applicable	Reserved (do not connect)	28	Reserved	Not applicable	Reserved (do not connect)
11	Reserved	Not applicable	Reserved (do not connect)	29	Reserved	Not applicable	Reserved (do not connect)
12	Node ID2	Input	Node ID coding Bit 2	30	Reserved	Not applicable	Reserved (do not connect)
13	ECU GND	Input	Ground for 12/24 V supply	31	Reserved	Not applicable	Reserved (do not connect)
14	CAN2_H	Bidirectional	Development CAN_H	32	Node ID1	Input	Node ID coding Bit1 (isolated digital input)
15	CAN2_L	Bidirectional	Development CAN_L	33	IP GND	Input	Designated ground for isolated digital input
16	CAN1_H	Bidirectional	J1939_H (Powertrain subnet)	34	Reserved	Not applicable	Reserved (do not connect)
17	CAN1_L	Bidirectional	J1939_L (Powertrain subnet)	35	Enclosure	Not applicable	Enclosure
18	ECU DO1	Output	Digital output				

# Wiring schematic

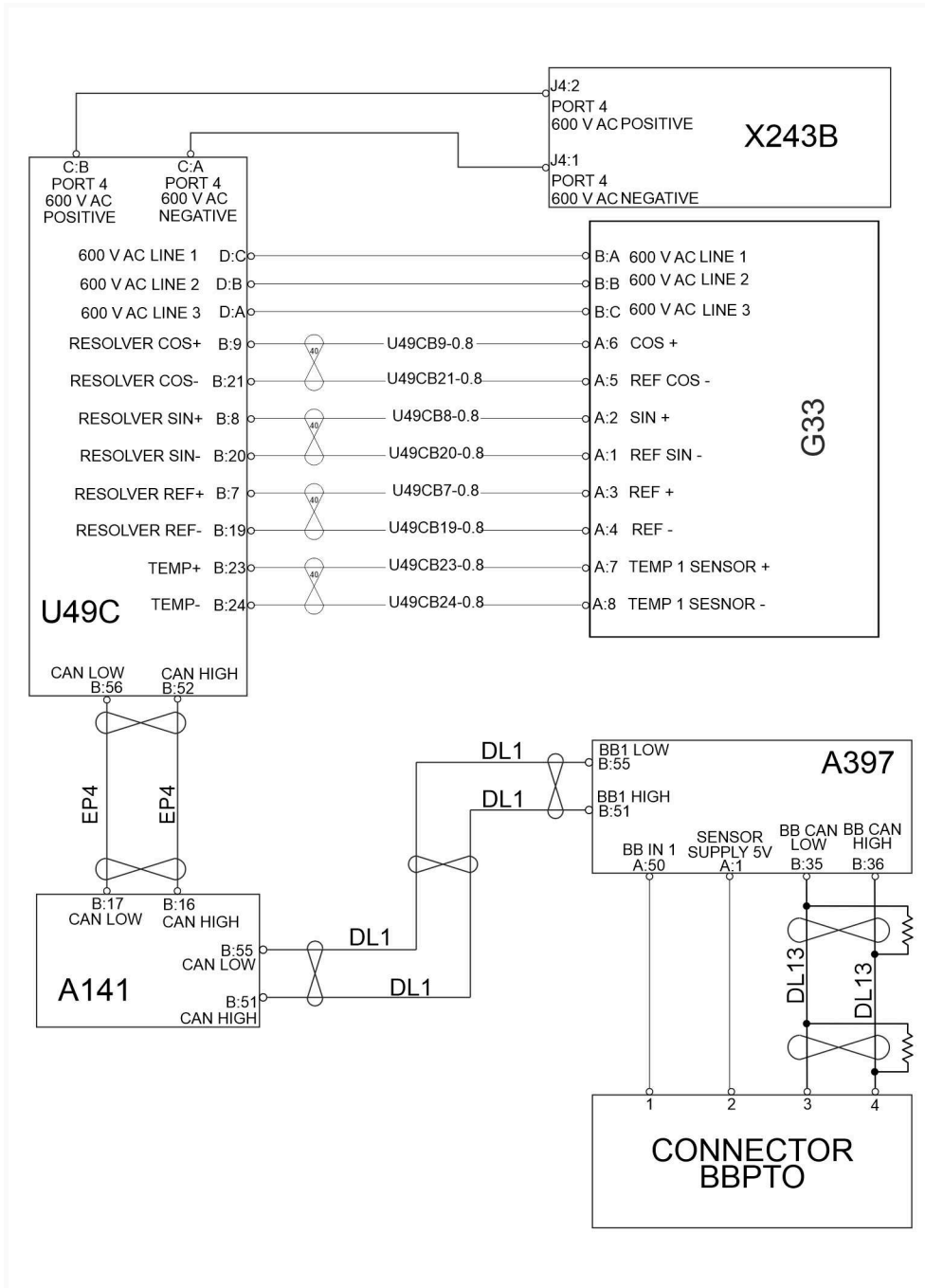

T3212012

A17	VECU
A141	HPCU
A397	EVCN
DL1	Data link 1 (Chassis)
EP4	Electromobility Subnet 4
G33	Electric Motor 3
U49C	EMD3 (Electric Motor Driver 3)
DL13	Data link (bodybuilder CAN)

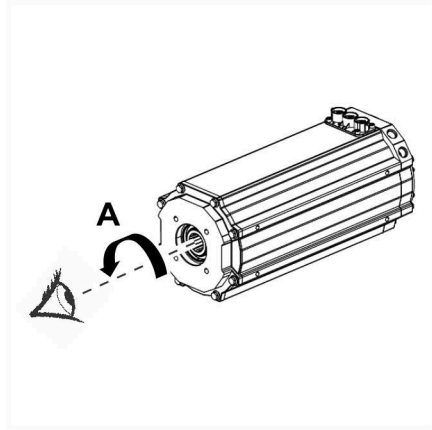

T2148171

**A** Direction of rotation (anti-clockwise by default).

**Note:** To change the direction of rotation of the mechanical ePTO, change the parameter configuration.

## Related Parameter



### CAUTION

During parameter configuration, do not start the truck and the traction batteries must not be charging mode.

All default values are given for guidance only. These values are subject to change and Volvo trucks may modify them without prior notice. Use tech tool to modify these values.

Parameter code	Description	Minimum	Default value	Maximum	Unit
P1UW5*	This parameter specifies the minimum power threshold above which use of the Mech. ePTO is permitted	0	50	255	kW
P1UXE	Motor direction of rotation (PWM control or set value) 0 = Counter-Clockwise direction of rotation <b>Note:</b> Parameter P1UW7 needs to be set to a positive value  1 = Clockwise direction of rotation <b>Note:</b> Parameter P1UW7 needs to be set to a negative value	0	0	1	-
P1UXF	Mech. ePTO speed of rotation acceleration rate	0	225000	255000	rpm/s
P1UXG	Mech. ePTO speed of rotation deceleration rate	0	255000	255000	rpm/s
P1UW7	Maximum speed of rotation of Mech. ePTO (PWM control)	-3790	N/A	3790	rpm
P1UW6	Mech. ePTO speed of rotation control mode: 0 = CAN 2 = set value	0	2	2	-
P1UW8	Mech. ePTO set value	0	900	16000	rpm
P1WWT*	This parameter specifies maximum torque value when P1UW6 is equal to 1 or 2	0	100	100	%

**Note:** \* Do not change the above parameters.

# Routing and Clamping

## Definitions

**Abrasive surfaces** : Items capable of causing damage to the routed commodity in a rubbing condition during vehicle operation (e.g. corrugated conduit, sharp edges, bolt thread, braided hose, etc.)

**Bundled with**: A number of items tied, wrapped or otherwise held together.

**Cable tie**: A plastic self-sizing strap, UV resistant, capable of bundling specified load(s) during vehicle operation.

**Chafing**: To wear away by rubbing/abrasion.

**Damaged**: An item that differs from its original condition.

**Electrical Cable**: Strands of wire encased in an insulated material designed to carry electric current.

**Fretting**: “Micro chafe” between pin terminal and socket terminal which in long term create oxides between the conductors causing misconduct.

**Insulation**: Material having good dielectric properties, which is used to separate close electrical components such as wire conductors.

**Not secured**: Items not fastened, bundled or tied.

**Plastic Conduit**: Corrugated or smooth wall tubing/hose used to protect hoses, harnesses, cables, tubing, pipes etc.

**Routed with**: Items taking the same path but not attached to each other (i.e. parallel but separate).

**Rubbing**: Items that contact each other and have independent movement.

**Screen**: A conducting layer placed around a wire or cable to limit the penetration or escape of electric or electromagnetic fields.

**Sharp edge**: Surface capable of cutting or piercing the routed commodity during vehicle operation.

**Signal Wiring Harness**: A set up of electric wires that distributes the electric current.

**Terminal**: The metallic component, applied to the wire, used for connection to a mating part and for further distribution of electric current.

**Traction Voltage**: Electric system operating at voltage level class B over 60V DC or 25V AC RMS defined in ISO 23273-3:2006

**Traction Voltage Power Cable**: Electrical cable used for conducting electrical current between components/units in the traction voltage system.

**Touch**: Items that are in contact but do not have independent movement.

## General

Electrical cables are used for conducting of current and it is therefore important that the routing and clamping are carried out in such a way that the current is not released due to chafing or other type of damage.

Traction voltage power cables are operating at a higher voltage level compared to conventional vehicles. Damages of the cable insulation can cause arcing that creates excessive heat. The traction voltage power cable conduct levels of current and contain voltage levels that when short-circuited or been damaged can cause functional disturbance and human hazards. The mounting, routing and clamping of the traction voltage power cable to avoid damage is therefore of extra importance.



### WARNING

Decommissioning and commissioning must only be carried out by personnel with adequate certification according to **Safety regulations, electric vehicles.**

# Installation guidelines

If damage of traction voltage power cables, terminals or connectors is found before, during or after the assembly process, it is not allowed to repair the cable. New parts must be installed.

Assemble or re-assemble of screws or nuts for terminals are specified to a torque which must be followed. It is strongly prohibited to diverge from this specification.

## Routing

- Traction voltage power cable that route along or through abrasive surfaces must not touch these surfaces e.g. sharp edges, rough edges, bolt thread, braided hose etc.
- If frame routing is used, routing through cross members are prohibited. Brackets must ensure that no contact with the frame is made and that the traction voltage power cables are secured from chafing at sharp edges.
- Where the traction voltage power cables must flex between mowing parts, the last supporting clamp/cable tie shall be securely mounted such that relative movement does not promote chafing.
- Traction voltage power cable shall not support any mechanical loads other than their own mass.
- Traction voltage power cables are prohibited from being located in areas that experience routine exposure to hydraulic fluid or oil spillage (i.e. underneath filters, below overflow vents, etc.)
- Minimum bend radius of the traction voltage power cable must be 4 times the cable diameter.
- Traction voltage power cables must not rub each other or surrounding items, but can touch when all items have the same relative movement.
- Traction voltage power cables must always be routed on top of brackets. In such cases, where routing underneath is necessary and/or sharp edges exists on the brackets, a rubber washer must be used to protect the cable from chafing on the bracket.
- Traction voltage power cable shall be protected from vibration and abrasion. Special attention must be given to under body, splash areas in wheel wells, and propulsion compartments where water and road abrasives can damage the cable.
- Avoid bending of the traction voltage power cable when exiting a connector/inlet, as this may cause a leak path in the rear seal of the connector/inlet.
- If cable tray/duct of metal is used for routing the traction voltage power cable, these must be electrical ground connected.
- Cable tray/duct sections must be connected to each other through the largest possible surface area to ensure a good electrical ground connection.

## Clamping

- The general maximum distance for clamping traction voltage power cable on powertrain is 5.9 inches.
- The general maximum distance for clamping traction voltage power cable on vehicle is 15.7 inches.
- Clamping high voltage power cable together with hydraulic lines is not allowed.
- When connecting to a component via a connector or inlet the distance between the connection and first clamping point must be short as possible to avoid vibrations and/or fretting in the connection. The general maximum distance is 3.93 inches.
- The first clamping point after a connection is preferably placed on the component. This to have the same relative movement between parts and in that way avoid vibrations and/or fretting in the connection.
- All bolted connections on the traction voltage power cable must be applied using specified torque and specified number of turns to ensure a good electrical and mechanical contact, else excessive heat may occur.



# Instrument Panel

Before driving this vehicle, check the instruments and controls and become thoroughly familiar with their operation. Ensure that the instrument readings are normal.

## Vehicle with dashboard switch gear selector

Without infotainment system

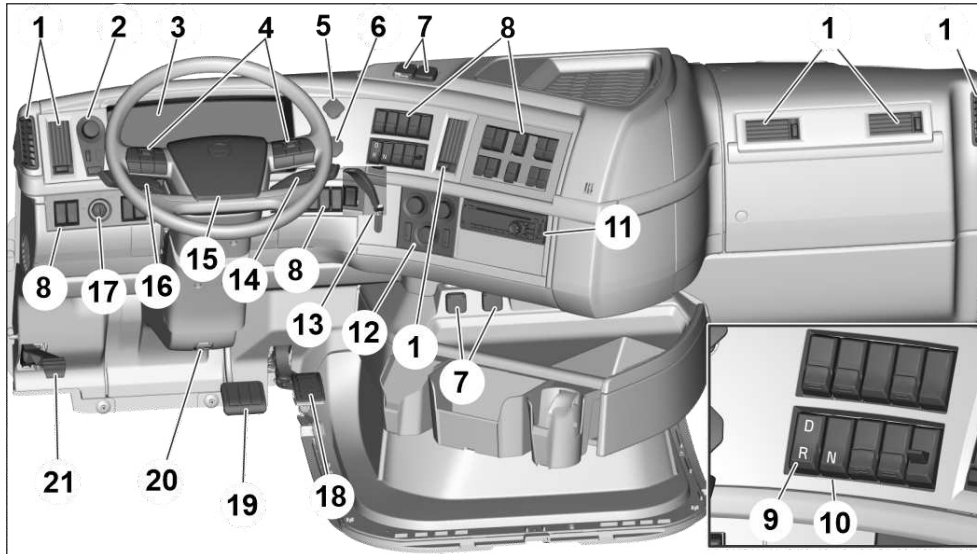

T3167587

1. Air vent	12. Climate control module
2. Exterior light control panel	13. Trailer Hand Brake
3. Instrument cluster	14. Stalk switch (RHS)
4. Steering wheel mounted controls	15. Horn
5. Tractor parking brake	16. Stalk switch (LHS)
6. Trailer air supply	17. Starter switch
7. Accessory power outlet/USB port	18. Accelerator pedal
8. Dashboard switches	19. Brake pedal
9. Drive/reverse switch	20. Hood latch
10. Neutral switch	21. Steering column tilt control pedal
11. Radio	

**With infotainment system**

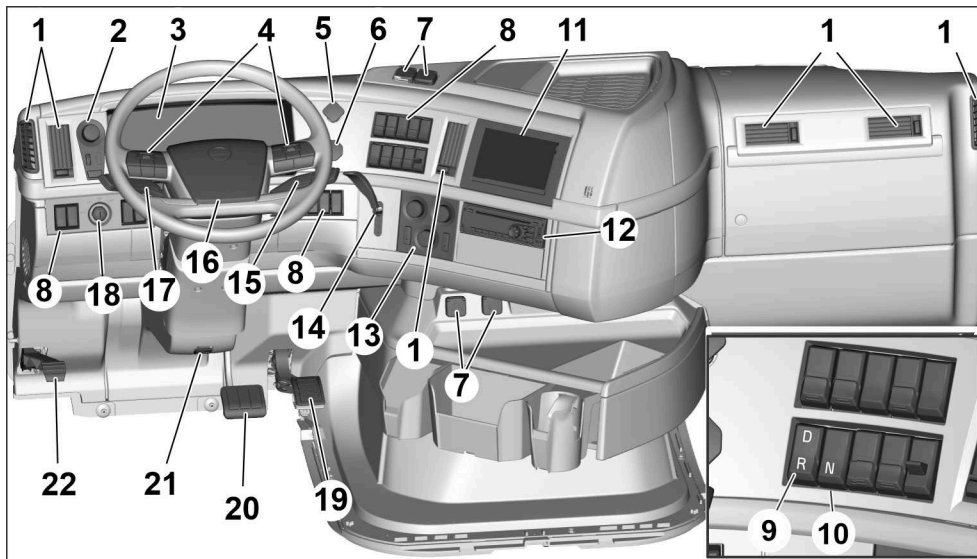

T3177674

1. Air vent	12. Radio
2. Exterior light control panel	13. Climate control module
3. Instrument cluster	14. Trailer Hand Brake
4. Steering wheel mounted controls	15. Stalk switch(RHS)
5. Tractor parking brake	16. Horn
6. Trailer air supply	17. Stalk switch (LHS)
7. Accessory power outlet/USB port	18. Starter switch
8. Dashboard switches	19. Accelerator pedal
9. Drive/reverse switch	20. Brake pedal
10. Neutral switch	21. Hood latch
11. Secondary Information Display (SID) (Infotainment Screen)	22. Steering column tilt control pedal

# Instrument Cluster

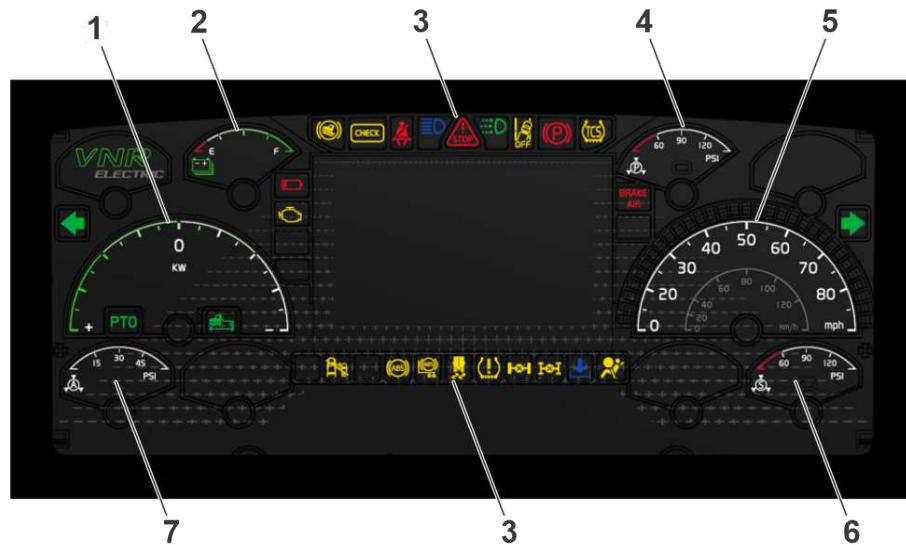

T3167588

- 1 Power meter
- 2 State of Charge (traction battery)
- 3 Tell-tale indicators
- 4 Air pressure gauge (Primary (P))
- 5 Speedometer
- 6 Air pressure gauge (Secondary(S))
- 7 Air pressure gauge (brake application (A))

## Notes

---

---

---

---

---

---

---

---

## Power meter

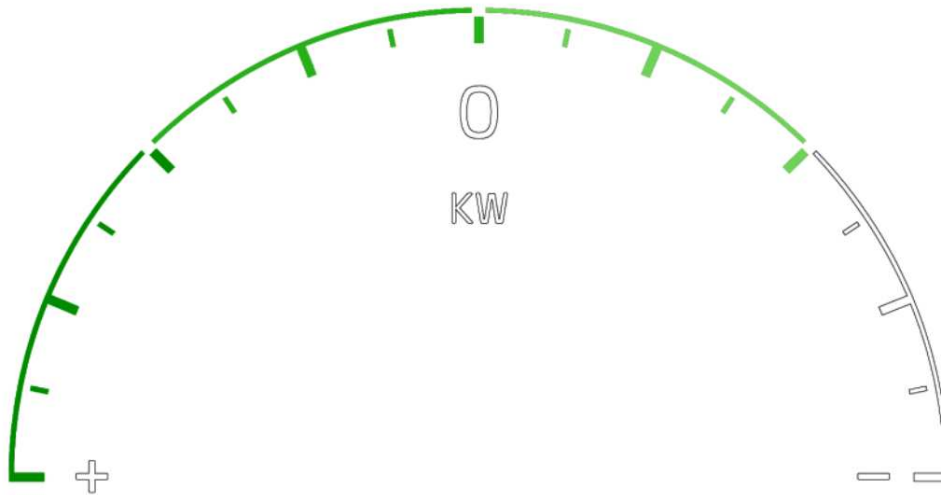

T3167589

The power meter shows the instantaneous use of energy for propelling the truck. The scale of the power meter is divided into two parts - negative to the right and positive to the left. Negative means that the propulsion system consumes energy from the traction batteries. Positive means that the traction battery regenerates the energy.

During braking, the digital meter indication moves to the left, showing the intensity of braking energy recovery. A gentle braking gives a higher braking-energy recovery than a heavy braking.

During acceleration, the digital meter indication moves to the right. The more energy that is consumed, the farther to the right the digital indication goes.

## Notes

---

---

---

---

---

---

---

---

---

---

## State of Charge (SOC)

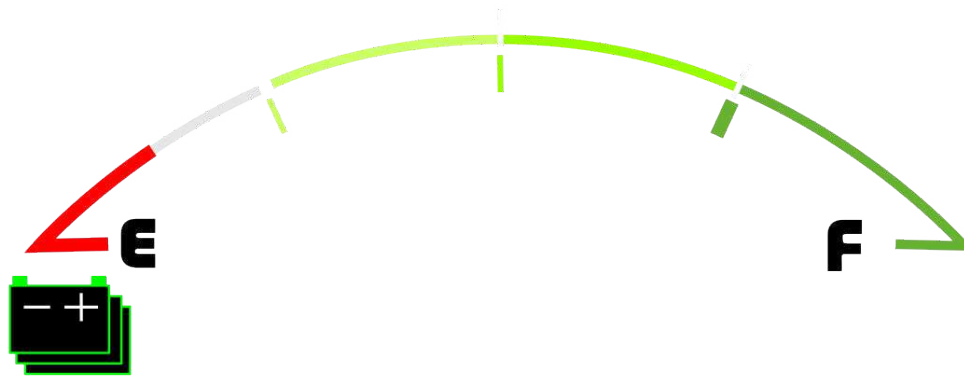

T3167590

The SOC gauge shows the amount of energy stored in the traction batteries. The scale of the SOC gauge ranges from 0% to 100% (left to right) and is divided into four equal parts (25% each). When the energy stored is 15% of the traction batteries' capacity, the tell-tale (traction battery low) turns on with a steady light. Charge the traction batteries as soon as possible. When the energy stored is only 5%, the tell-tale (traction battery low) flashes. Charge the traction batteries immediately.

We can customize the levels for when the tell-tale must turn on with a steady and/or flashing light. Contact an authorized Volvo Dealer to do the necessary changes.

## Air pressure gauge (Primary (P))

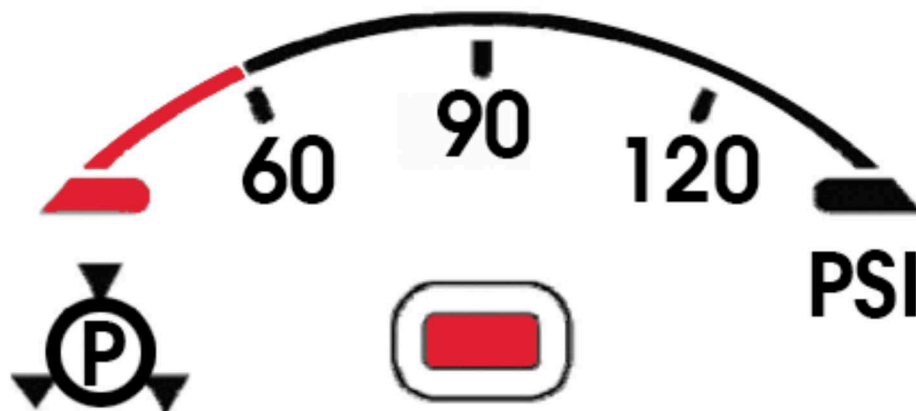

T3167708

The air pressure gauge (P) displays the pressure of the air stored in the primary air tank. The primary and secondary air pressure gauges must display equal pressures under normal operating conditions.

## Speedometer

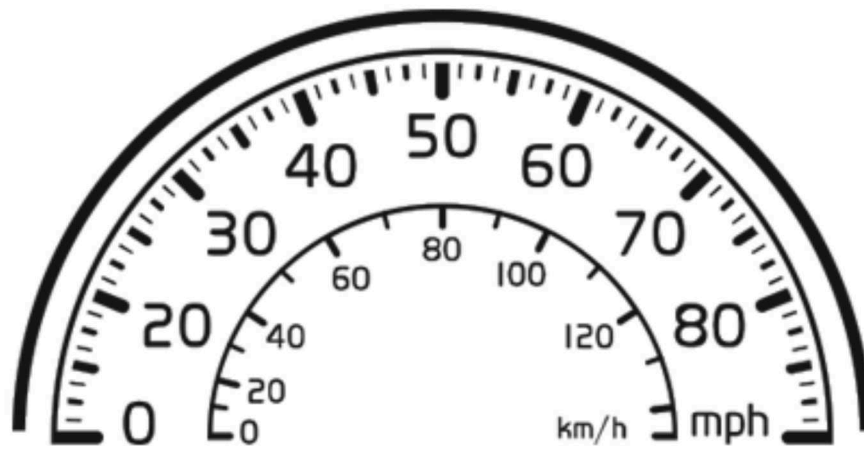

T3167709

The speedometer shows the speed of the vehicle. Vehicle electronic system drives the speedometer.

## Air pressure gauge (Secondary (S))

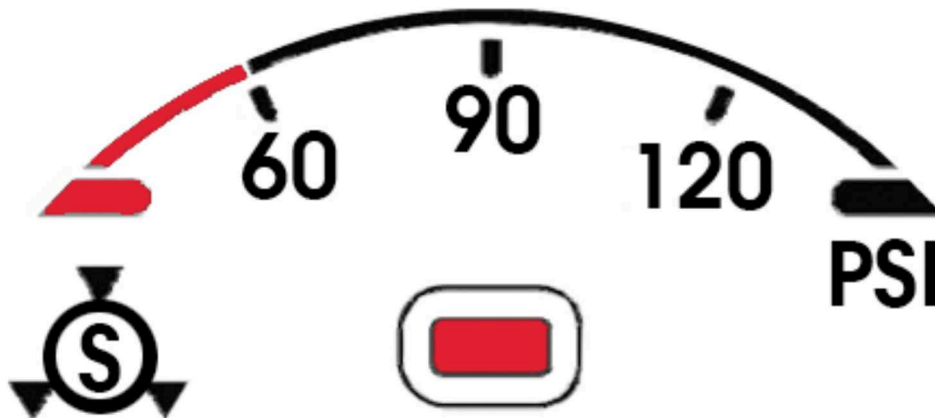

T3167710

The air pressure gauge (S) displays the pressure of the air stored in the secondary air tank. The primary and secondary tank air pressure gauges must display equal pressures under normal operating conditions.

**Air Pressure Gauge (brake application (A))**

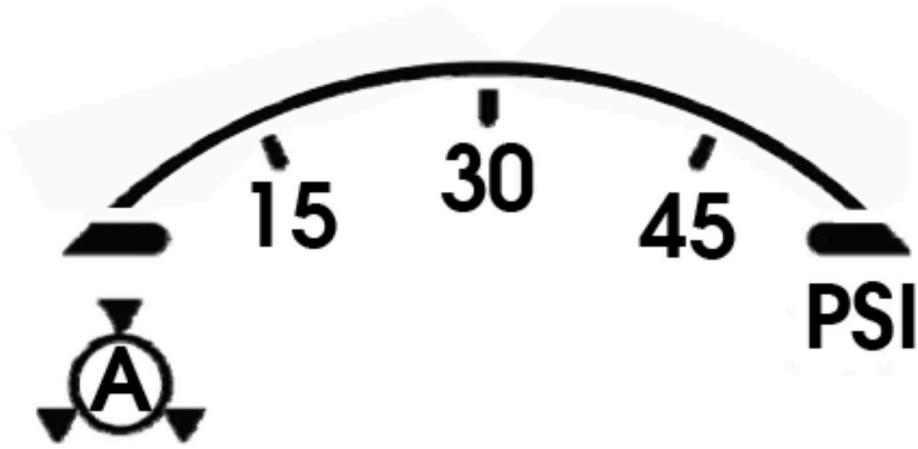

T3167711

The air pressure gauge (A) shows the brake system pressure that includes the front, rear and the trailer brake circuits. The gauge will not show air pressure until the footbrake pedal or the trailer hand brake is applied.

**Notes**

---

---

---

---

---

---

---

---

---

---

---







## Tell-tale indicators









A tell-tale indicator indicates the actuation of a device, a correct or defective condition, or a failure to function. The operator must become familiar with these symbols to recognize and react (if necessary) to the indicated condition. Tell-tale symbols are shown in the instrument cluster.









### Colors:

To promote visual recognition internationally, specific colors for tell-tales are established. Unless governmental regulations (in the area where the vehicle is used) or engineering directives specify otherwise, the standard colors are:

- Steady Blue — high-beam headlights
- Flashing Green — turn signals
- Flashing Red — hazard condition involving the safety of personnel
- Steady Green — system in operation
- Steady Red — warning, immediate action required
- Amber — early warning, such as Anti-Lock Brake System (ABS) malfunction

	Tell-tale	Meaning	Description
1	 T3167687	Malfunction Indicator Lamp (MIL)	Indicates that a government Regulation on-board diagnostic (OBD) fault exists.
2	 T3167688	Hill Start Assist (HSA) indicator	Indicates that the Hill Start Assist is active.
3	 T3167690	Stop	<p>Illuminates when conditions require the driver to stop the vehicle. This usually occurs when vehicle conditions fall below designated standards for operation.</p> <div style="border: 1px solid black; padding: 5px; margin-top: 10px;"> <p> <b>DANGER</b></p> <p>Failure to take necessary action when the STOP tell-tale is on can ultimately result in automatic shutdown and loss of power steering assist. The vehicle may crash, resulting in personal injury or death.</p> </div>
4	 T3167691	Inter-axle differential lock	Illuminates when the inter-axle differential lock is engaged.
5		Inter-wheel differential lock	Illuminates when the inter-wheel differential lock is engaged.

	T3167692		
6	 T3167693	Turn signal indicator	Flashes when the turn signals are active.
7	 T3167694	Parking brake engaged	Indicates that the parking brake is engaged.
8	 T3167695	Safety belts reminder	Indicates to fasten the safety seat belt.
9	 T3167696	ABS malfunction trailer	Indicates a trailer Anti-lock Braking System (ABS) malfunction.
10	 T3167697	ABS malfunction tractor	Indicates a tractor Anti-lock Braking System (ABS) malfunction.
11	 T3167698	High beam indicator	Illuminates when the high beam lights is On.
12	 T3167699	Check indicator	Illuminates when there is an electrical issue.
13	 T3167700	Traction Control System (TCS) indicator	Indicates the Traction Control System (TCS) is active.
14	 T3167701	Lane Departure Warning System (LDWS) indicator	Indicates the Lane Departure Warning System (LDWS) is off.

15	 T3167702	Power take-off (PTO) indicator <b>Note:</b> If PTO option is not applicable, the tell-tale will not illuminate.	Indicates that the power take-off (PTO) is active.
16	 T3167703	Electronic Stability Control (ESC) indicator	Indicates that the Electronic Stability Control (ESC) system is active.
17	 T3167704	Daytime Running Light (DRL) indicator	Indicates that the Daytime Running Lights (DRL) are active.
18	 T3167705	Lane Changing System (LCS) indicator	Indicates that the Lane Change System (LCS) is off or disabled.
19	 T3167706	Airbag indicator	Indicates that there is an airbag error. Maintenance is required.
20	 T3167707	Tire pressure monitoring System (TPMS) indicator <b>Note:</b> TPMS feature is not applicable for VNR Electric. The tell-tale never turns on.	Indicates that there is an issue with the tire pressure.
21	 T3167595	Driveline engaged	Indicates that the propulsion system is on and the vehicle speed is below 3 mph (5 km/h).
22	 T3167591	Software download in progress	Indicates that the software download is in progress.
23	 T3167592	Traction battery low	Indicates that the traction battery is low. Charge the traction battery immediately.



# Dashboard switches

## Switch layout-1

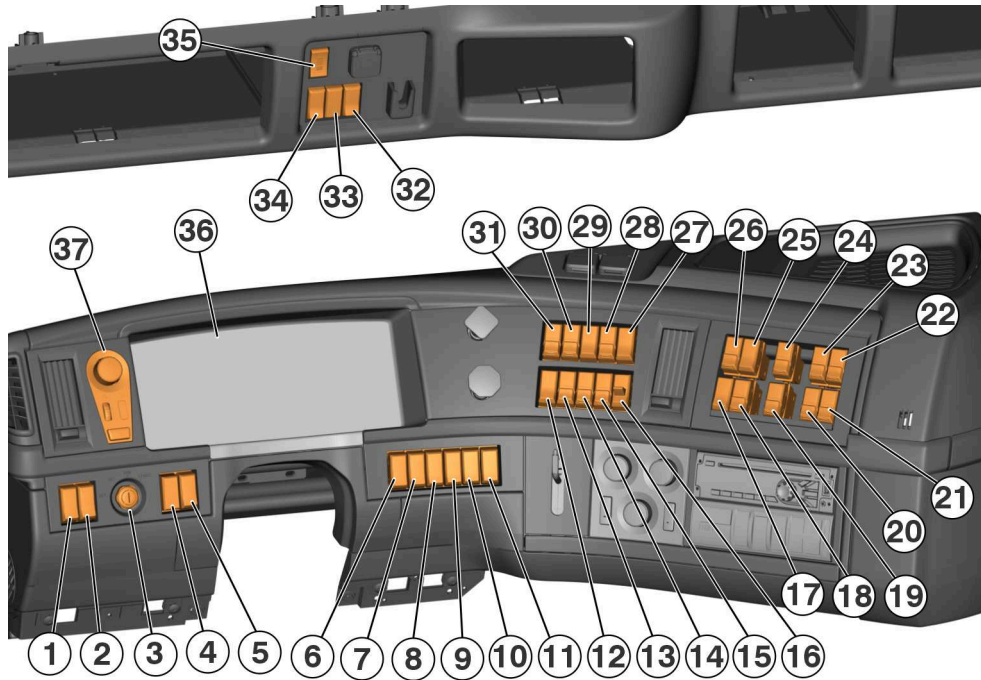

T3179430

Position	Description
1	Back of Cab light
2	Pre-trip inspection
3	Starter switch
4	Blank
5	Blank
6	Blank
7	Blank
8	AUX or blank
9	AUX or blank
10	AUX or Heated windshield or blank
11	Blank
12	Drive and reverse switch or bogie control
13	Neutral switch or ECS ON/OFF
14	ECS UP/DOWN
15	Bogie control or blank
16	Fifth wheel unlock
17	Blank
18	Blank
19	Blank
20	Blank

21	Blank
22	Blank
23	Blank
24	Blank
25	Blank
26	Blank
27	Hill start assist
28	Fifth wheel slide or inter-wheel differential lock or blank
29	ATC (MUD/SNOW+ATC OFF)
30	ECS UP/DOWN
31	Inter-axle differential lock or blank
32	LDWS disable switch or data capture switch or blank
33	Blank
34	DRL override switch or blank
35	Microphone or blank
36	Instrument cluster
37	Exterior light control panel

**Notes**

---



---



---



---



---



---



---



---



---



---



---

## Switch layout-2

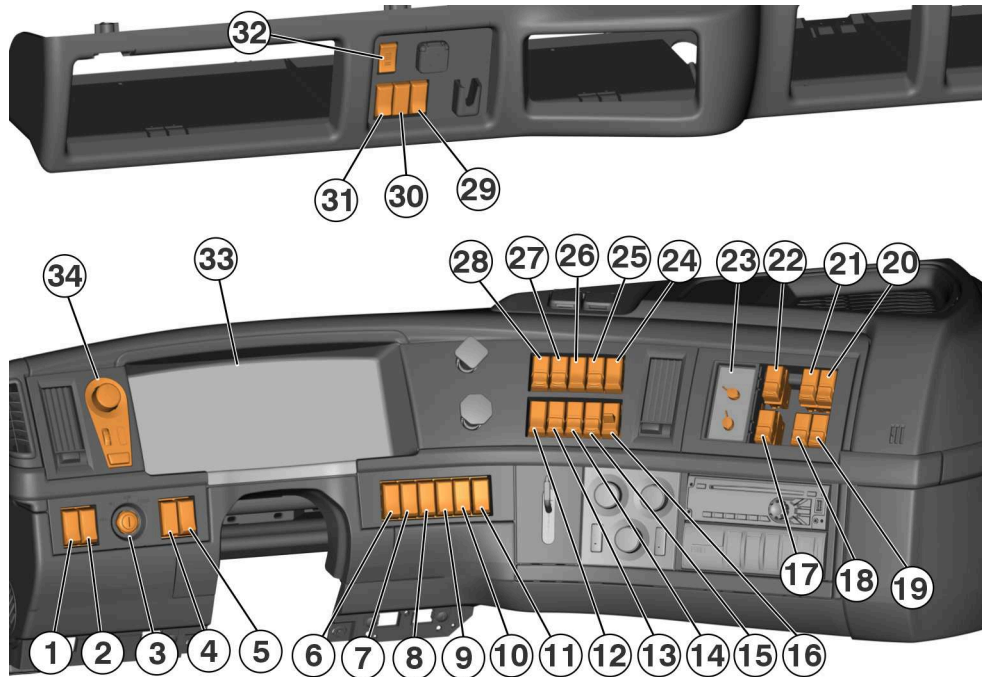

T3179431

Position	Description
1	Back of Cab light
2	Pre-trip inspection
3	Starter switch
4	Blank
5	Blank
6	Blank
7	Blank
8	AUX or blank
9	AUX or blank
10	AUX or Heated windshield or blank
11	Blank
12	Drive and reverse switch or bogie control
13	Neutral switch or ECS ON/OFF
14	ECS UP/DOWN
15	Bogie control or blank
16	Fifth wheel unlock
17	Blank
18	Blank
19	Blank
20	Blank
21	Blank
22	Blank

23	Secondary gauges
24	Hill start assist
25	Fifth wheel slide or inter-wheel differential lock or blank
26	ATC (MUD/SNOW+ATC OFF)
27	ECS UP/DOWN
28	Inter-axle differential lock or blank
29	LDWS disable switch or data capture switch or blank
30	Blank
31	DRL override switch or blank
32	Microphone or blank
33	Instrument cluster
34	Exterior light control panel

*Notes*

---



---



---



---



---



---



---



---



---



---

### Switch layout-3

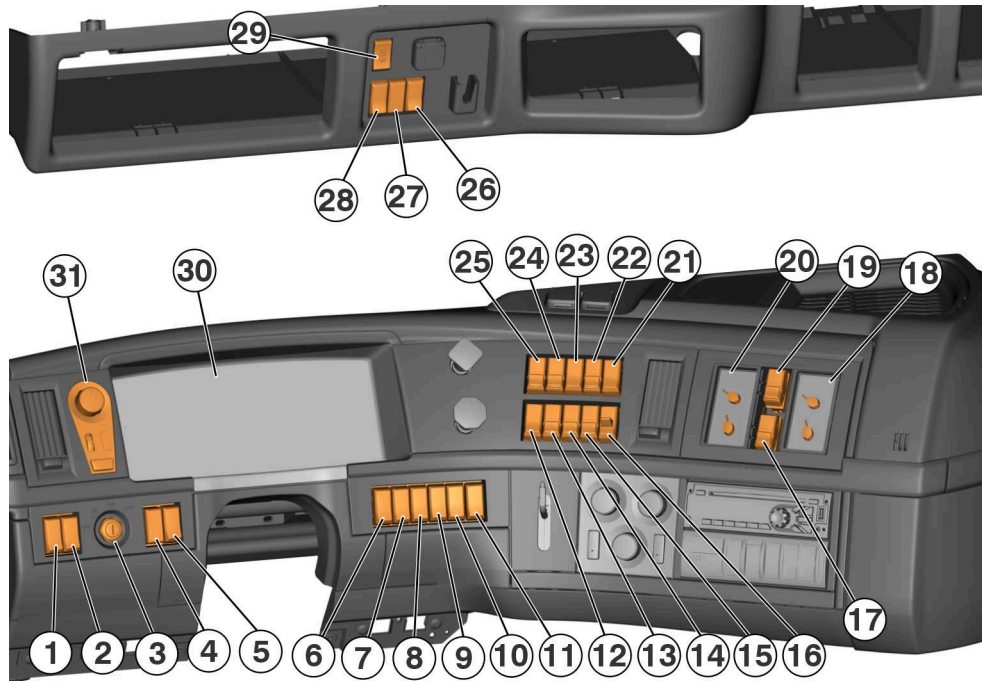

T3179432

Position	Description
1	Back of Cab light
2	Pre-trip inspection
3	Starter switch
4	Blank
5	Blank
6	Blank
7	Blank
8	AUX or blank
9	AUX or blank
10	AUX or Heated windshield or blank
11	Blank
12	Drive and reverse switch or bogie control
13	Neutral switch or ECS ON/OFF
14	ECS UP/DOWN
15	Bogie control or blank
16	Fifth wheel unlock
17	Blank
18	Secondary gauges
19	Blank
20	Secondary gauges
21	Hill start assist

22	Fifth wheel slide or inter-wheel differential lock or blank
23	ATC (MUD/SNOW+ATC OFF)
24	ECS UP/DOWN
25	Inter-axle differential lock or blank
26	LDWS disable switch or data capture switch or blank
27	Blank
28	DRL override switch or blank
29	Microphone or blank
30	Instrument cluster
31	Exterior light control panel

*Notes*

---



---



---



---



---



---



---



---



---



---

## Switch layout-4

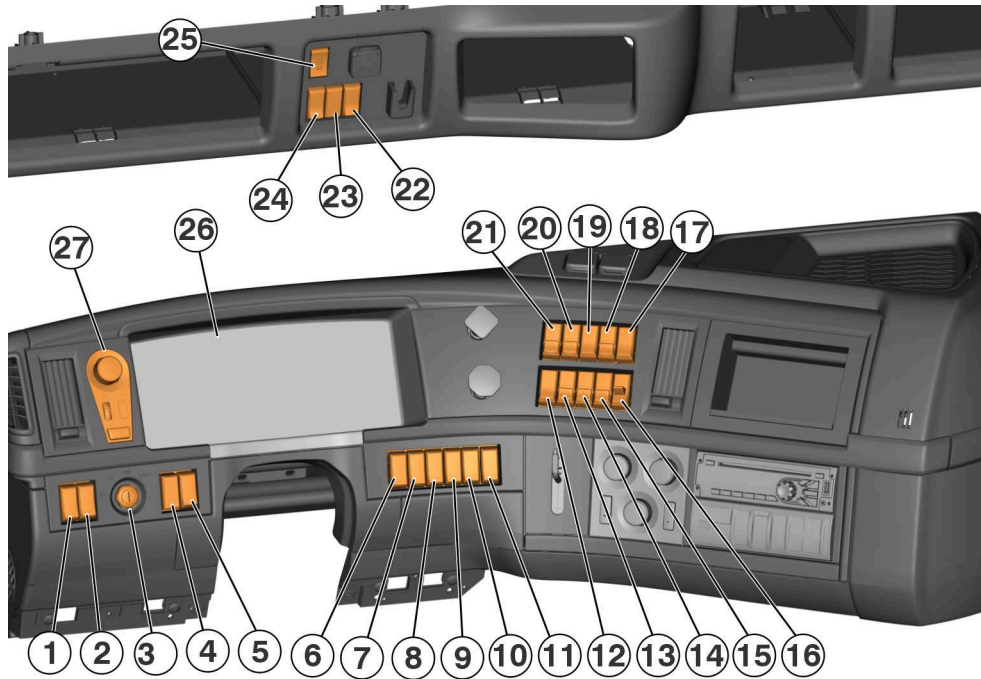

T3179433

Position	Description
1	Back of Cab light
2	Pre-trip inspection
3	Starter switch
4	Blank
5	Blank
6	Blank
7	Blank
8	AUX or blank
9	AUX or blank
10	AUX or Heated windshield or blank
11	Blank
12	Drive and reverse switch or bogie control
13	Neutral switch or ECS ON/OFF
14	ECS UP/DOWN
15	Bogie control or blank
16	Fifth wheel unlock
17	Hill start assist
18	Fifth wheel slide or inter-wheel differential lock or blank
19	ATC (MUD/SNOW+ATC OFF)
20	ECS UP/DOWN
21	Inter-axle differential lock or blank

22	LDWS disable switch or data capture switch or blank
23	Blank
24	DRL override switch or blank
25	Microphone or blank
26	Instrument cluster
27	Exterior light control panel

*Notes*

---



---



---



---



---



---



---



---



---



---

# Steering wheel mounted controls

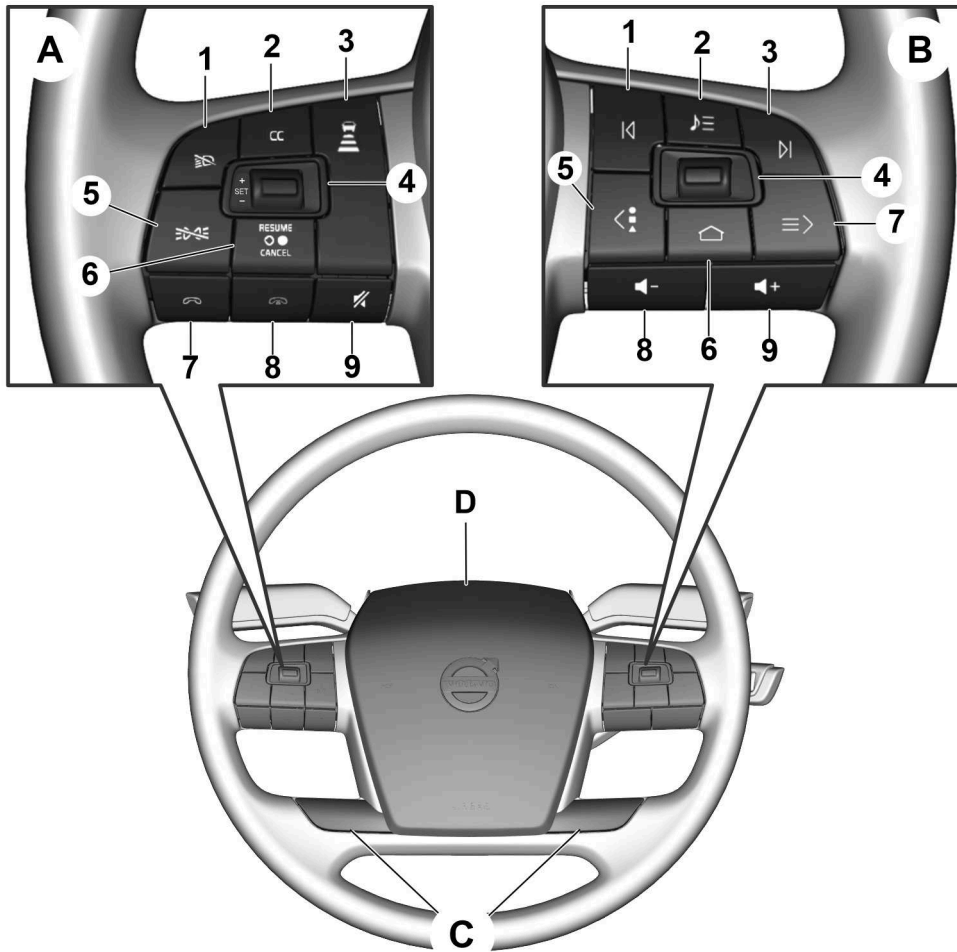

T3178370

<b>A</b>		Steering wheel mounted controls (LHS)	<b>B</b>		Steering wheel mounted controls (RHS)
	1	Headlamp flash		1	Seek left
	2	Cruise Control On/Off		2	Radio mode
	3	Cruise Control following distance selection		3	Seek right
	4	Toggle/scroll up and down/enter		4	Toggle/scroll up and down/enter
	5	Marker lamp flash		5	Application/left
	6	Cruise Control cancel/resume		6	Home
	7	Accept call (green)		7	Options/back/right
	8	End call (red)		8	Volume down
	9	Mute call/radio		9	Volume up
<b>C</b>		Air horn	<b>D</b>		Electric horn

# Stalk switch controls

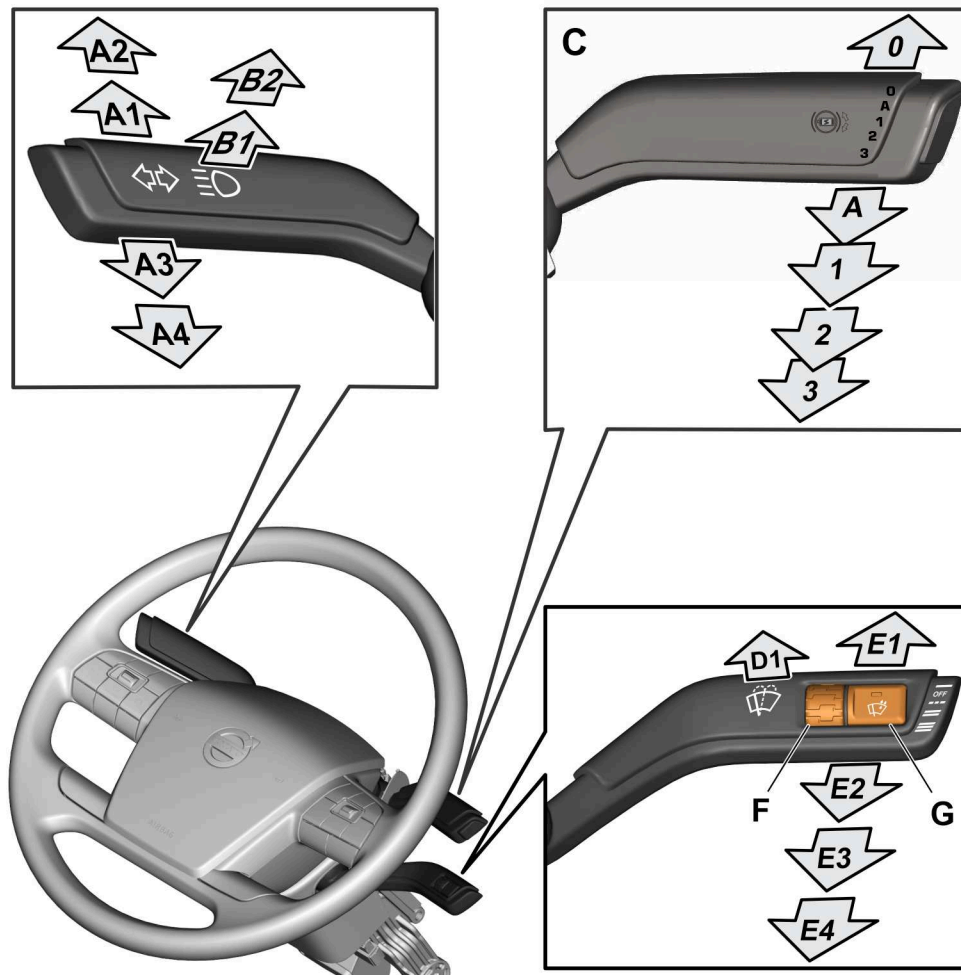

T3178371

<b>A1</b>	Turn signal right (right turn temporary – five flashes)
<b>A2</b>	Turn signal right, On (right turn continuous flash)
<b>A3</b>	Turn signal left (left turn temporary – five flashes)
<b>A4</b>	Turn signal left, On (left turn continuous flash)
<b>B1</b>	Headlamp (flash)
<b>B2</b>	Headlamp On
<b>C</b>	Stalk switch (regenerative brake)
	0 – Off position
	A - On or Position-A (brake blending) (25% to 50% of regenerative braking)
	1 - Position-1 (20% to 40% of regenerative braking)
	2 - Position-2 (40% to 70% of regenerative braking)
	3 - Position-3 ( 60% to 100% of regenerative braking)
<b>D1</b>	Windshield washer
<b>E1</b>	Windshield wiping at normal speed for as long as the stalk switch is held in the spring-loaded position
<b>E2</b>	Intermittent wiping

<b>E3</b>	Windshield wiper, normal speed
<b>E4</b>	Windshield wiper, high speed
<b>F</b>	Scroll wheel (to set the intermittent wiping interval - four levels available)
<b>G</b>	Rain sensor switch (On/Off) (can only be switched On when the windshield wiper is switched Off)

For more information on the instruments and controls, refer to the driver's handbook.

**Notes**

---

---

---

---

---

---

# Suspension

## Front axle alignment

### Axle set back

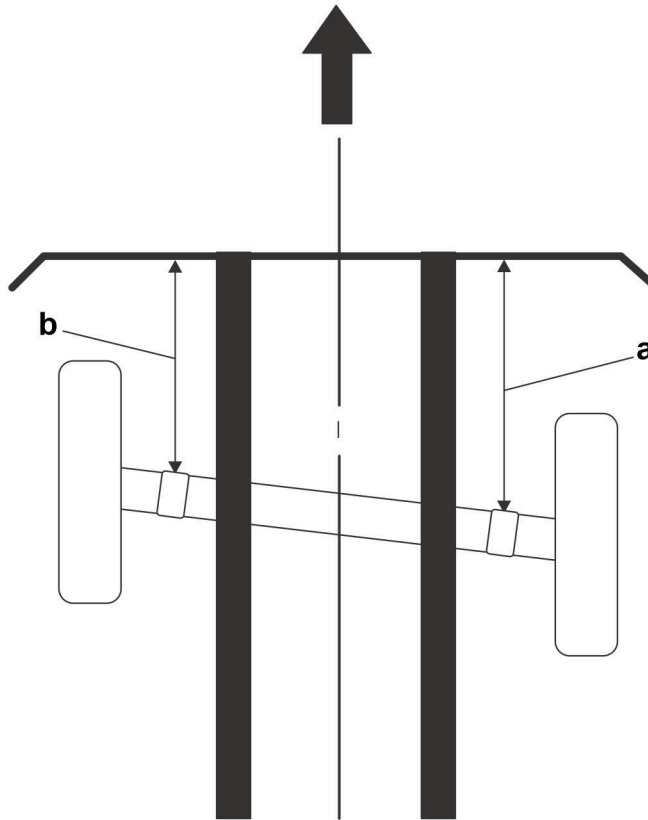

T8173080

**a.** Distance measured from the front of vehicle to the front axle member (RHS).

**b.** Distance measured from the front of vehicle to the front axle member (LHS).

The difference between **a** and **b** is called axle setback. The axle setback is measured with the wheels of steering axle in a straight ahead position. It is used to identify chassis misalignment or assembly issues with the front suspension.

<b>Front axle set back</b>	$0 \pm 6$ mm (0.25 inches)
----------------------------	----------------------------

## Straight forward position

### LHD:

When the thrust angle of the first drive axle measures as  $0^\circ \pm 0.02^\circ$  on the left-hand side, a vehicle is in a straight forward position.

### RHD:

When the thrust angle of the first drive axle measures as  $0^\circ \pm 0.02^\circ$  on the right-hand side, a vehicle is in a straight forward position.

To measure the wheel toe-in or toe-out, ensure that the vehicle is in a straight forward position.

## Wheel camber

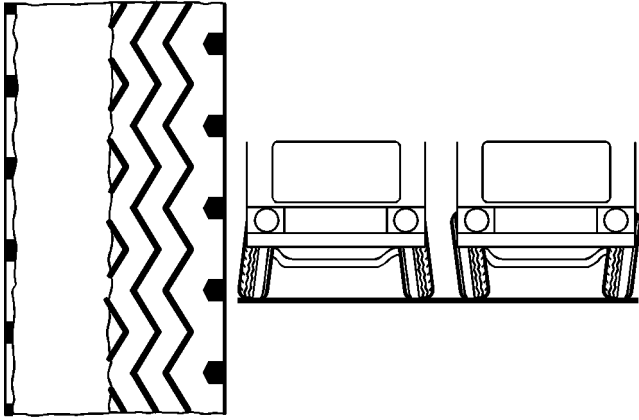

T1006458

Axle Manufacturer (Front axle)	Wheel camber
Volvo	$1/4^\circ \pm 7/16^\circ (0.25^\circ \pm 0.43^\circ)$
Rockwell	$-1/4^\circ \pm 7/16^\circ (-0.25^\circ \pm 0.43^\circ)$

Wheel camber is machined into the axle assembly at the time of manufacture and is not adjustable. Wheel camber is positive when the wheel is tilted outward at the top and is negative when the wheel is tilted inward at the top.

Wheel camber decreases when the axle load increases. The difference between RHS and LHS wheel camber values must not vary more than  $0.5^\circ$ . If the wheel camber angle is more than the given specifications, contact the axle manufacturer. Do not bend the axle or use other methods to adjust the wheel camber angle. Incorrect wheel camber causes tire wear.

## Wheel caster

The angle that is formed when the steering axle king pin is tilted rearward or forward with reference to the vertical plane is called the wheel caster (A). The wheel caster is positive when the steering axis is tilted rearward and is negative when the tilt is forward.

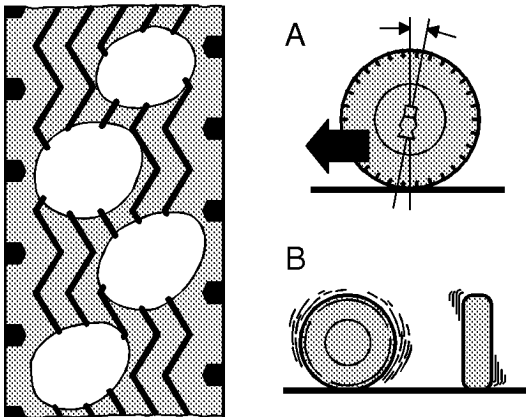

T1006460

**A** Wheel caster angle  
**B** Imbalance

Wheel caster	$4^\circ \pm 1^\circ$
--------------	-----------------------

To measure the wheel caster, ensure that the vehicle is in an unloaded condition, and the steering axle and drive axles are on a level surface.

The difference between RHS and LHS wheel caster values must not vary more than 0.5°. If the wheel caster angle is more than the given specifications, use the caster shims to adjust the caster angle. Do not bend the axle or use other methods to adjust the wheel caster angle.

**Note:** The wheel caster is measured from ground.

## Wheel toe

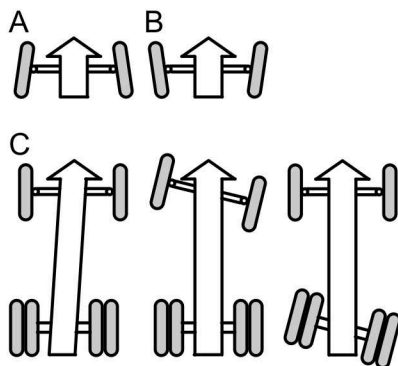
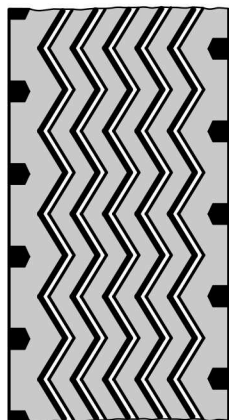

W1079988

- A Toe-in
- B Toe-out
- C Out-of-line axle

<b>Toe-in angle</b>	$1/16" \pm 1/32" (.06" \pm .03")$ or $0.08^\circ \pm .04^\circ (.04^\circ \text{ to } .12^\circ)$ or $1.5 \text{ mm/m} \pm 0.75 \text{ mm/m}$
---------------------	---

To adjust the toe-in or toe-out, ensure that the vehicle is in unloaded condition. Measure the toe-in or toe-out at the front and rear tread center of the tires at a distance above the ground equal to the rolling radius of the tires. The toe-in or toe-out values are also measured with equipment that senses the difference between left-hand and right-hand thrust angles.

**Note:** When adjusting the toe-in or toe-out, ensure that the clamp bolt of tie rod is in the vertical position. Improper orientation could result in incorrect adjustment.

## Front suspension

Model	FSS-LEAF (FST-PAR)
Suspension type	Leaf
Number of leaves	2
Leaf type	Parabolic leaf
Axle model	Meritor MFS, Meritor MFS+ and FL-941 Meritor Volvo axle 5.7 and 6.7 tonne

## Parabolic leaf spring suspension (FST-PAR)

	Clamped	Unclamped
<b>Rated load</b>	5216 kg (11499 lbs)	-
<b>Stress at rated load</b>	482 MPa	-
<b>Spring rate (<math>\pm 7\%</math>)</b>	1114 N/mm	-
<b>Loaded camber (<math>\pm 3</math>)</b>	44.5 mm (1.75 inches)	-
<b>Free camber (<math>\pm 3</math>)</b>	90 mm (3.5 inches)	-
<b>Deflection to rated load</b>	3.49 inches	-

# Rear axle alignment

## Axle centering

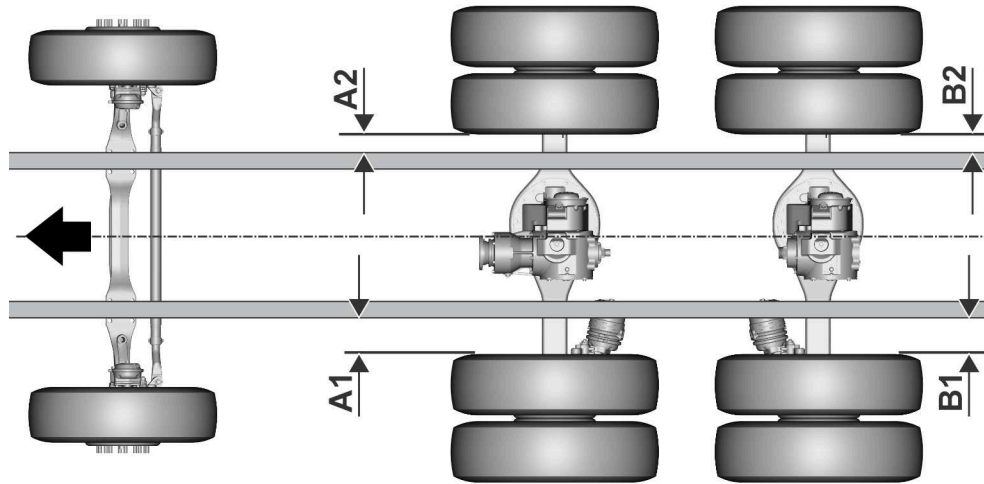

T7173256

All axles must be centered to the chassis (laterally). The maximum side to side difference of a rear axle is  $A1 - A2 = 0 \pm 4$  mm ( $0 \pm 0.156$  inches).

The maximum difference between the front drive axle to the rear drive axles is  $A1 - B1$  or  $A2 - B2 = 8$  mm (0.312 inches). If the axle is not centered, check the transverse torque rod length (if equipped) and torque rod spacers.

## Thrust angle (axle perpendicularity)

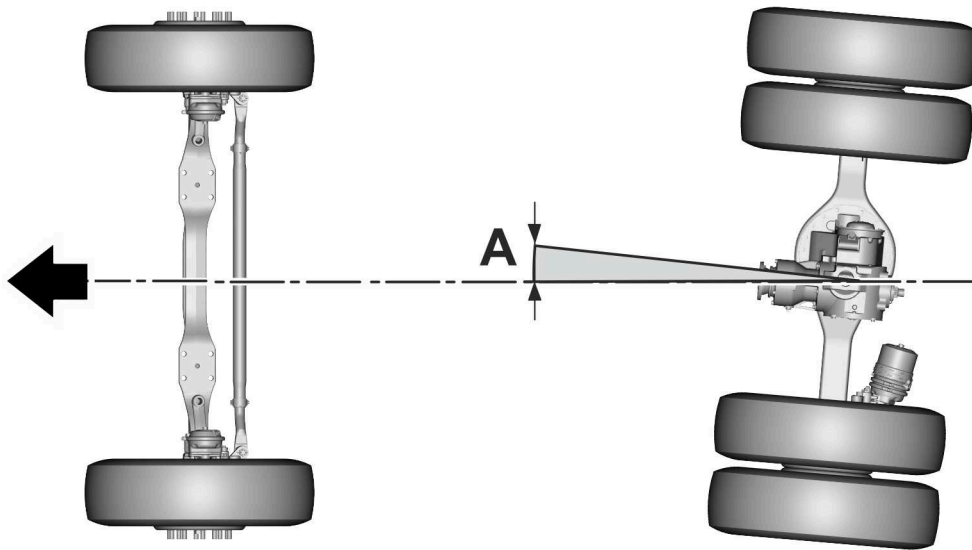

T6173259

The thrust angle is an angle between the centerline of the chassis and the direction that the axle is pointed.

<b>Thrust angle (A)</b> VOAS	$0^\circ \pm 0.08^\circ$
---------------------------------	--------------------------

A thrust angle other than 0° pushes the truck sideways thus increases tire wear. When the thrust angle is 0°, the axle is perpendicular to the chassis centerline.

## Scrub angle (axle parallelism)

The scrub angle is the angle between the centerline of the first drive axle and the second drive axle.

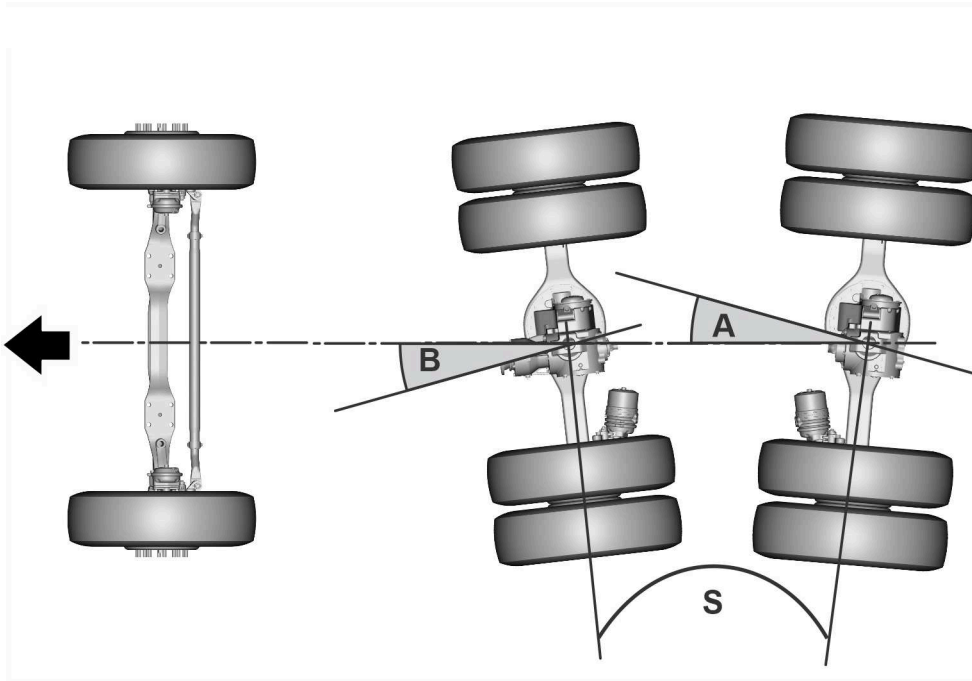

T6173258

<b>Scrub angle (S)</b> VOAS (RADD-A4V)	$0^\circ \pm 0.08^\circ$
---	--------------------------

It is important that all drive axles are parallel to each other and pointing towards the same direction. If the front drive axle has a 0.03° thrust angle (B), then set the thrust angle of rear drive axle (A) also to 0.03°. Any difference in thrust angle will cause the drive axles to work against each other and cause the vehicle to drift in different directions. This will greatly increase tire wear on all axles and increase drag from the scrubbing.

To meet the scrub angle tolerance, compare the thrust angle of the second drive axle (A) with the thrust angle of the front drive axle (B). Ideally, these two values must read the same with the same sign (+ or -). It is very important to have B and A with the same sign. Scrub angle (S) = B – A .

## Rear Suspension

Model	VOAS
Suspension type	Air
Number of leaves	1
Leaf type	Z Spring
Axle model	RS1045SM, RS1236SD, RS1257SM and RT1873SE

## Ride height adjustment

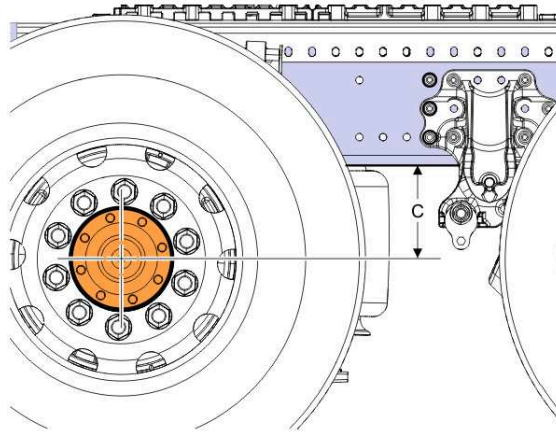

N365038

The ride height (**C**) is measured from the centre of the first drive axle hub to the bottom of the frame.

**Note:** Fill the air springs to the correct pressure before measuring the ride height.

### Procedure to measure ride height

1

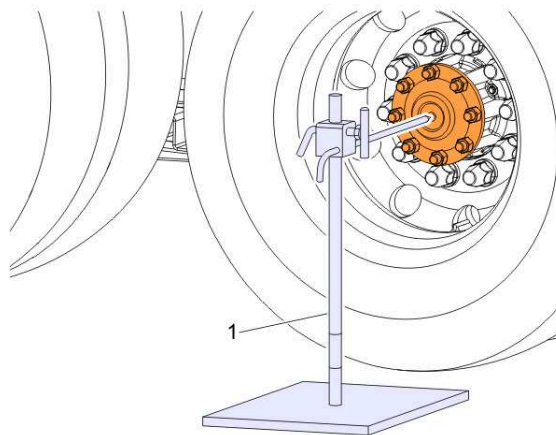

N365039

Place the tool (**1**) near to the first drive axle and position the pointer to the centre of the axle hub.

**Note:** Park the vehicle on a level surface.

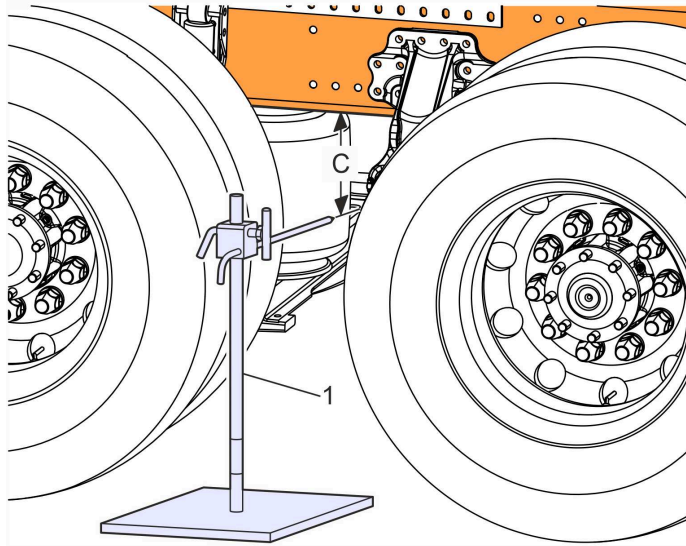

T7179339

Move and position the tool (1) between the drive axles and below the frame. Measure the ride height (C) from the tip of the pointer to the bottom of the frame.

## Ride heights

Rear suspension height (A)	Frame height (B)	Ride height (C)	
		Loaded	Unloaded
RSH-STD	FRAMEHIG (FRAME300)	193 ±5 mm (7.6 ±0.2 inches)	203 ±5 mm (8 ±0.2 inches)
	FRAMELOW (FRAME266)	210 ±5 mm (8.2 ±0.2 inches)	220 ±5 mm (8.6 ±0.2 inches)
RSH-HIG	FRAMEHIG (FRAME300)	213 ±5 mm (8.3 ±0.2 inches)	223 ±5 mm (8.7 ±0.2 inches)
	FRAMELOW (FRAME266)	230 ±5 mm (9 ±0.2 inches)	240 ±5 mm (9.4 ±0.2 inches)

**Note:** Vehicles that have a 6x2 pusher axle configuration are equipped with ECS (Electronically Controlled Suspension). So the unloaded ride height is the same as the loaded ride height (use the loaded values for a vehicle that is unloaded) because the ECS automatically adjusts the rear ride height.

## Pinion angle measurement

**Note:** Check ride height before checking the pinion angle.

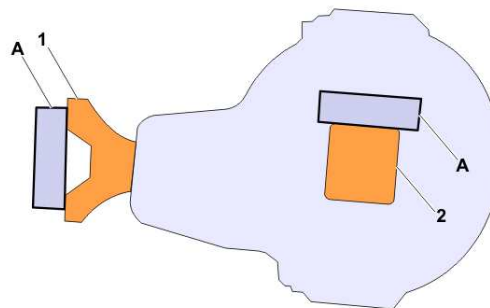

N365902

(A) Inclinometer

- (1) Yoke
- (2) Axle housing

**Note:** Zero the inclinometer before checking the pinion angle.

Place the inclinometer on the top surface of the frame rail, above the axle with the height control valve. The inclinometer must be parallel to the frame rail. Zero the inclinometer on the frame rail.

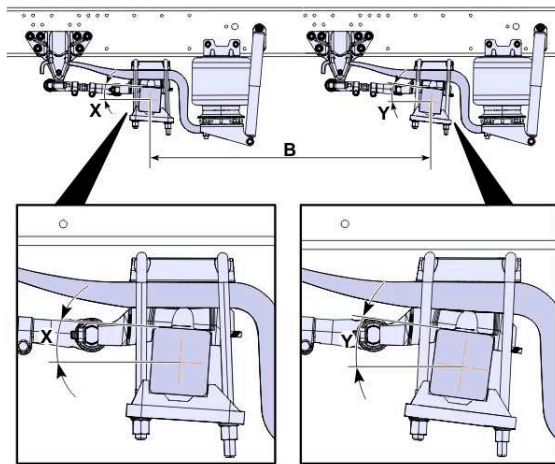

N365903

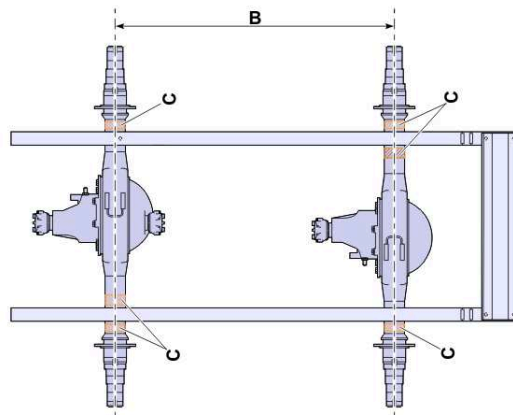

N365905

- (B) Bogie spread (distance between the first and second rear drive axles)
- (C) Area for the axle pinion angle measurement
- (X) First drive axle, pinion angle
- (Y) Second drive axle, pinion angle

## Pinion angles

Bogie spread (B)	Rear suspension height	First drive axle, pinion angle (X)				Second drive axle, pinion angle (Y)			
		Loaded		Unloaded		Loaded		Unloaded	
		On yoke face (1)	On axle housing (2)	On yoke face (1)	On axle housing (2)	On yoke face (1)	On axle housing (2)	On yoke face (1)	On axle housing (2)
4x2 (RAD-A2V and RAD-A2L) with RS1045SM (MERITOR, RS-23-160/161, MS-23-16*)									
NA	RSH-STD RSH-HIG	2.9±1°	3.4±1°	3.0±1°	3.5±1°	NA			
6x2 (RAD-A2L) with RS1236SD (DANA 26082)									
NA	RSH-STD	2.4±1°				NA			
4x2 (RAD-A2V and RAD-A2L) with RS1257SM (MERITOR, RS-26-185/MS-26-18*)									
NA	RSH-STD	4.4±1°	4.9±1°	4.5±1°	5.0±1°	NA			
6x4 (RADD-A4V) with RT1873SE (EATON D40-172E)									
NA	RSH-STD	2.16±1°		3.38±1°		0.34±1°		1.32±1°	

## Notes

---



---



---



---



---



---



---



---



---



---

# Lighting

For lighting information, refer to Section-3 of Heavy Duty Body Builder Information (subsection – “Add-on Exterior Lighting”).

## Notes

---

---

---

---

---

---

---

---

---

---

# ECU Functions and Parameter Programming

This section lists functions, which will be of interest to Body Builders and others needing to modify certain (programmable) aspects of the ECUs. If an ECU is not included in this section, it is because there are no adjustable functions, which can be modified in the field.

Not all functions or parameters listed in this document may apply to the vehicle you have, because of running changes and improvements made over time. Using each component's Main Software part number, the Premium Tech Tool knows which parameters apply and show only those which are adjustable for that particular vehicle.

Whenever working on the electrical system of the vehicle, certain ECUs such as the Airbag (SRS) ECU, need special handling to avoid damage. Refer to the appropriate ECU sections, and to the individual ECU service manual, for the appropriate precautions.

All ECUs use some form of Input and Output devices to perform their functions. These devices may include switches, sensors, solenoids and relays. Do not tie or splice into an existing sensor or input device used by an ECU or else proper operation of that sensor may be affected. Likewise, Do not tie into an Output device that is controlled by an ECU unless authorized to do so in this document.

Always observe proper Electrostatic Discharge (ESD) precautions while working around the ECUs, as outlined in the "Service Procedures" portion of this document.

The Inputs and Outputs (I/O) of the ECUs follow a certain "logic" that are important to understand when interfacing to the ECUs. The following information explains the terminology used in this document:

Input/Output Type	Definition
Active High (or Active +V)	<p>This input is typically configured with a switch wired to + Voltage. The two states of input are either floating (switch open), or +V (switch closed). The input is considered active when +V is applied.</p> <div data-bbox="662 1045 1239 1285" data-label="Diagram"> <p style="text-align: right;">W9000629</p> </div>
Active Low (or Active ground)	<p>This input is typically configured with a switch wired to ground. The two states of input are either floating (switch open), or grounded (switch closed). The input is considered active when grounded.</p> <div data-bbox="662 1507 1239 1747" data-label="Diagram"> <p style="text-align: right;">W9000630</p> </div>
NC switch to +V	<p>This input type typically has a Normally Closed (NC) switch contact connected to +V. The input becomes active when the switch is opened or the circuit is otherwise broken.</p>

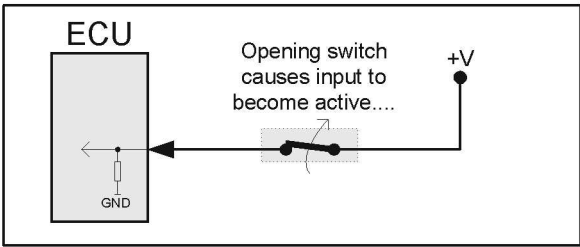
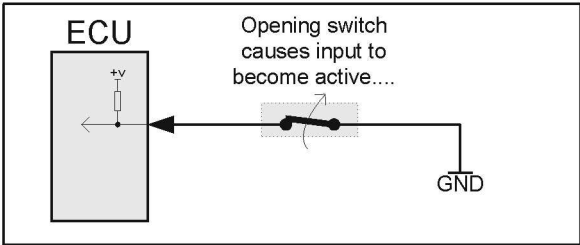
Input/Output Type	Definition
	<div data-bbox="737 144 1313 388" style="border: 1px solid black; padding: 5px;">  </div> <p data-bbox="1247 426 1328 445" style="text-align: right;">W9000631</p>
NC switch to ground	<p data-bbox="516 474 1539 537">This input type typically has a Normally Closed (NC) switch contact connected to the ground. The input becomes active when the switch is opened or the circuit is otherwise broken.</p> <div data-bbox="737 573 1313 816" style="border: 1px solid black; padding: 5px;">  </div> <p data-bbox="1247 848 1328 867" style="text-align: right;">W9000632</p>

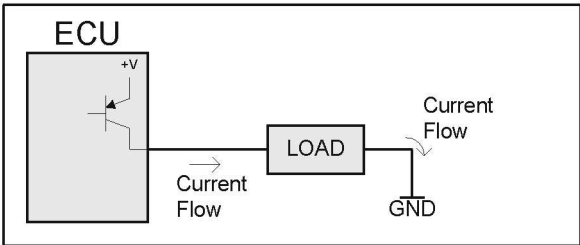
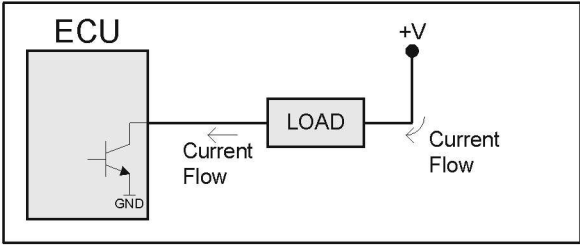
Input/Output Type	Definition
<b>OUTPUTS</b>	
Active High	<p data-bbox="516 1014 1539 1077">This output source current (the voltage goes high) when active. The other side of the load or controlled device is connected to ground.</p> <div data-bbox="737 1113 1313 1356" style="border: 1px solid black; padding: 5px;">  </div> <p data-bbox="1247 1388 1328 1407" style="text-align: right;">W9000633</p>
Active Low	<p data-bbox="516 1440 1539 1503">This output sinks current (the voltage goes low, usually to the ground) when active. The other side of the load-controlled device must be connected to +V.</p> <div data-bbox="737 1535 1313 1778" style="border: 1px solid black; padding: 5px;">  </div> <p data-bbox="1247 1808 1328 1827" style="text-align: right;">W9000634</p>

Many of the functions on the vehicles are shared among different ECUs. Use the following guide to help decide which ECU controls which functions:

Feature/Function	ECU
Road Speed Limit Parameters	PCM
Auto Neutral Parameter	EVCN
Cruise Control Parameters	VECU
Regenerative Brake Levels	(not adjustable)
ATVSA disable/enable	HPCU
TVS Inhibition	HPCU

## Road speed limit

### Function

This function gives ability to limit the vehicle speed. This limit is separate from all other vehicle speed limits (such as CC max set speed, max Road Speed Governor, etc.). When multiple road/vehicle speed limits are imposed, the lowest will have priority. It can be used on refuse trucks to limit the speed, if a man is standing on the back of the vehicle.

Soft-top speed limit means the highest speed limit that applies during soft-top operation. Maximum soft-top duration means the maximum amount of time that a vehicle could operate above the default speed limit. Certified VSL means a VSL configuration that applies when a vehicle is new and until it expires

### PCM- Road speed limit Parameters

Parameter code	Parameter caption	Parameter description	Minimum	Default value	Maximum	Unit
AI	Cruise Control max speed	The maximum speed that can be set in the Cruise Control.	30	130	140 87	km/ h mp- h
P1ALV	Legal Road Speed Limit	The legal RSL that is set to the vehicle.	30	?	140 87	km/ h mp- h
P1AOC	Customer Road Speed Limit	<p>Specifies the customer selectable maximum speed the vehicle can operate on level road. The vehicle speed will be limited by the lowest of the following:</p> <ul style="list-style-type: none"> <li>Customer Road Speed Limit (P1AOC)</li> <li>Road Speed Limit (P1ALV)</li> <li>Secondary Road Speed Limit (Request via CAN-signal from Body Builder Module) if available</li> </ul> <p>For markets that use performance bonus: Any additional speed granted by the Performance Bonus feature will be added to the Customer Road Speed Limit (P1AOC) value, as (so) long as the overall</p>	30	Not applicable	140 87	km/ h mp- h

		maximum of 140 km/h (87 MPH) is not exceeded. Any speed penalty imposed by the Differential Road Speed Governor will be subtracted from this maximum value. Maximum Cruise Control Speed must be set less than or equal to the accelerator-pedal maximum specified by the Customer Road Speed Limit (P1AOC) value.				
P1I16	RSL With Pedal	The pedal vehicle speed limit, which is used to set a higher or lower pedal vehicle speed. Its intended to be used together with Road speed limit function to make the driver want to use Cruise Control.	0	Not applicable	140 87	km/h mp-h
P1MG2	RSL difference between loaded and unloaded vehicle	Difference in Road Speed Limit between loaded and unloaded vehicle. The lowered speed limit is relative to the Customer Road Speed Limit.	0	Not applicable	6553.5 4072	km/h mp-h
P1MG3	Use lower road speed limit on loaded vehicle	Select if the negative offset shall be applied on loaded or unloaded vehicle. <b>No:</b> The offset is applied on unloaded vehicle. <b>Yes:</b> The offset is applied on loaded vehicle. For weight Road Speed Limit, the offset is relative to the Customer Road Speed Limit (P1AOC).	0	Not applicable	1	—
P1MG4	Bellow pressure threshold for loaded vehicle	For weight-based Road Speed Limit, the vehicle is considered loaded if the pressure in the suspension bellows is above this value.	0	Not applicable	6553.5	kPa
P1Y0M	RSL reverse driving configuration	Configures the maximum vehicle speed used for reversing. The vehicle speed will be limited by the lowest value of this configuration parameter and all other road speed limits when the vehicle is reversing. This configuration parameter will not affect the vehicle speed limit when the vehicle is driving forward.	5	Not applicable	140 87	km/h mp-h

## Cruise Control

The Cruise Control function will maintain a driver selected vehicle speed regardless of terrain or other vehicle load conditions.

## Pin/Connector Information

This function uses the Cruise Control stalk switches. See the VECU I/O table for pin locations of the Cruise Control On/Off, Resume, and Set + / Set - button inputs.

## Prerequisites/Conditions for Activation

- The function is enabled in the VECU.
- Cruise Control stalk switch set to the On position.
- Current vehicle speed is between Cruise Control MAX and MIN vehicle speed parameters.
- Brake pedal is released.
- No Vehicle Speed Sensor (VSS) related faults.
- No J1939 control data link related faults in the VECU or PCM.

Press the SET+ or SET- switch to select the current vehicle speed as the "set" speed. A Cruise Control ("CC") icon will appear in the instrument cluster while the Cruise Control governor is engaged. Once active, the SET buttons may be used to adjust the CC set speed within programmed limits. Speed changes may be made either as a "ramp" (by holding the SET+ or SET- button), or as a "step" change (by tapping the buttons).

The Cruise Control Maximum Set Speed is the maximum vehicle speed allowed while in CC mode.

CC mode may differ (be higher or lower) from the overall maximum vehicle speed limit set in the PCM, but the overall speed limit will be enforced if it is lower than the CC Maximum Set Speed.

If disengaged for any reason (any of the prerequisites above are no longer met), the Cruise Control resume button will re-engage Cruise Control and restore the last "set" speed.

If load or terrain conditions are such that the vehicle speed is reduced below the Minimum Governed Speed while the Cruise Control is engaged, the Cruise Control governor will drop out.

**Parameter codes (VECU 4)**

Parameter Name	Code	Default Value	Range	Description
F_ENABLE_CRUISE_CONTROL	AG	1	0/1	Enables the CC Function
CC Maximum Set Speed	AI	130 km/h (81 m/h)	30 km/h ~ 140 km/h (19 m/h ~ 87 m/h) must be > BK	Maximum CC Set speed allowed
CC Minimum Set Speed	BK	30 km/h (19 m/h)	30 km/h ~ 140 km/h (19 m/h ~ 87 m/h) must be < AI	Minimum CC Set speed allowed
CC Minimum Governed Speed	BL	15 km/h (9 mph)	15 km/h ~ 30 km/h (9 m/h ~ 19 m/h)	Vehicle speed below which the Cruise governor will no longer attempt to maintain preset speed
Cruise Trim Factor	GP	2 km/h per second (1 mph/ per second)	0 km/h ~ 10 km/h (0 m/h ~ 6 m/h) per second	Specifies the speed change ramp (in km/h per second) that will be requested when the SET+ button is held
Cruise Trim Factor Minus	RR	2 km/h per second (1 mph/ per second)	0 km/h ~ 10 km/h (0 m/h ~ 6 m/h) per second	Specifies the speed change ramp (in km/h per second) that will be requested when the SET- button is held
Cruise Step Factor	RS	2 km/h (1 mph)	0 km/h ~ 10 km/h (0 m/h ~ 6 m/h)	Specifies the step speed change (in km/h) that will be requested when 'tapping' either the SET+ or SET- buttons

**Notes**

---



---



---



---



---



---



---



---



---



---

# Auto Neutral

Auto neutral will put the transmission into neutral when the parking brake is set. Once the parking brake is released, the shifter will need to be placed in drive (D) for the transmission to go back into gear. Auto neutral improves job-site safety for a variety of applications.

## ATVSA Enable/Disable

When the chassis switch is in the On position, the ATVSA (Automatic Traction Voltage System Activation) function can be activated automatically without any special action being taken and irrespective of the position of the Starting key or of the connection to the off-board charger. There are various reasons why the 600 V circuit may be reactivated:

- To maintain charge in the 24 V system batteries to have the vehicle ready to run for next key cycle or starting cycle (when the truck is parked).
- To maintain the cell temperature of the traction batteries by preconditioning them both by cooling and heating. Preconditioning improves the SOH (State Of Health) of the traction batteries.
- To maintain the cell temperature of the traction batteries by post conditioning (after-run mode) them both by cooling and heating. Post condition improves the SOH the traction batteries.
- To activate 600 V power distribution for body builder function when requested, example fridge body.

The electromobility system periodically wakes-up the 24 V system to check the 24 V system battery charge level and battery cell temperature of the traction batteries. After the preconditioning assessment, the traction voltage supply is enabled if required or else remain disabled.

To perform a specific task with chassis switch in on position and key OFF, the ATVSA function has to be disabled to avoid automatic activation of cooling fans, heater and other components etc. The ATVSA can be enabled or disabled using Premium Tech Tool operation “3650-05-03-01 Automatic Traction Voltage system Activation, control”.

**Note:** “3650-05-03-01 Automatic Traction Voltage system Activation, control” disables or enables both the ATVSA and TVS together. ATVSA functionality cannot be disabled without inhibiting TVS.

### HPCU - ATVSA Parameter

Parameter code	Parameter description	Minimum	Default value	Maximum	Unit
P1R0B	Electric Vehicle, ATVSA Function, Enable/Disable	0	1	1	—

# TVS (Traction Voltage System) Inhibition

Inhibit the TVS before performing certain diagnostic operations that are otherwise prevented from being performed. Follow the TVS inhibition routine provided in Premium Tech Tool.

## HPCU-Routine

DOID code	DOID description
R1DY0	Traction Voltage System, Force Shutdown

**Preconditions:** The vehicle shall be in key on (Pre-running) but not running vehicle mode.

### Test Sequence:

- 1 Check that the preconditions are fulfilled.
- 2 Run the routine. The TVS is commanded to de-energize.
- 3 When the routine is complete, check that P1V2F reports False meaning that the TVS is de-energized.

**Note:** The parameter P1V2F is not editable or programmable. The parameter is to check the TVS status.

**System Behavior:** The TVS will de-energize safely (if energized) and not re-energize until the starter key position changes.

TVS can be inhibited using Premium Tech Tool operation "3650-05-03-01 Automatic Traction Voltage system Activation, control".

**Note:** "3650-05-03-01 Automatic Traction Voltage system Activation, control" disables or enables both the ATVSA and TVS together. TVS cannot be inhibited without disabling ATVSA.

## Notes

---

---

---

---

---

---

---

---

# Vehicle Electronic Control Unit (VECU)

There are many programmable features of the VECU, the functions listed here are included because they will be of particular interest to body builders and others needing to modify certain aspects of the VECU. For a complete list of all programmable parameters, see the appropriate Premium Tech Tool parameter and reprogramming information.

## Description of VECU Signals (VECU 4)

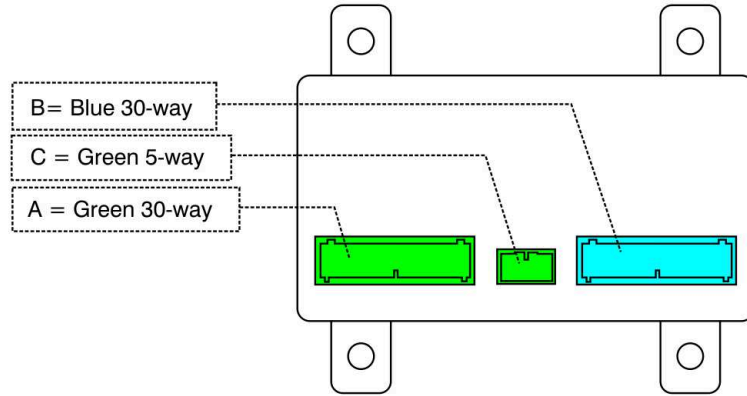

W3088359

## VECU Connector A (Green)

Pin	Pin Name/Description	I/O	Type	Comment
A1	CC Set (-) SW	Input	Active High	
A2	CC Set (+) SW	Input	Active High	
A3	CC On/Off SW	Input	Active High	
A4	Spare	Spare	Spare	
A5	Brake Pedal Microswitch	Input	NC Switch to +V	NO SWITCH INSTALLED. WIRED TO +V
A6	Key Switch: START	Input	Active High	
A8	No Connection	—	—	—
A9	Spare	Input	Active High	
A10	Spare	Input	Active High	
A11	Starter Control	Input	Active High	—
A12	ECU Ground	ECU Main Power Ground		
A13	ECU Main Power	Input	ECU Main Power	
A14	Key switch: RUN	Input	Active High	

Pin	Pin Name/Description	I/O	Type	Comment
A15	CAN2-High (J1939H) DL5	Bidirectional Data Link		
A16	CAN2-Low (J1939L) DL5	Bidirectional Data Link		
A17	No Connection	—	—	—
A18	Idle Validation Switch-2	Input	Active High	Not used
A19	No Connection	—	—	—
A20	No Connection	—	—	—
A21	No Connection	—	—	—
A22	No Connection	—	—	—
A23	Idle Validation Switch-1	Input	Active High	
A24	AC Hi-pressure Fan Switch Input	Input	NC Switch to Ground	Open Switch = High AC Pressure = Fan Requested
A25	No Connection	—	—	—
A26	Spare	Input	Active Low	
A27	No Connection	—	—	—
A28	No Connection	—	—	—
A29	No Connection	—	—	—
A30	CC Resume Switch	Input	Active High	

**Notes**

---



---



---



---



---

## VECU Connector B (Blue)

Pin	Pin Name/Description	I/O	Type	Comment
B1	ECAD Regeneration Control	Output	Active Low	Air Dryer ECADS
B2	Starting Relay	Output	Active Low	
B3	No Connection	—	—	—
B4	ECAD Compressor Control	Output	Active Low	Air Compressor ECADS
B5	Output Supply # 4 (-V batt)	Output	Switch Power	
B6	Vehicle Speed Sensor (+)	Input	Analog	
B7	No Connection	—	—	—
B8	Accelerator Pedal	Input	Analog Sensor	
B9	Air Tank Pressure	Input	Analog Sensor	ECADS
B10	Accelerator Pedal Supply-1 (~5 V)	Output	Sensor Power	
B11	Parking Brake	Input	Active Low	Ground connected N.C. air switch (No air = switch closed = PB applied)
B12	Spare	Input	Active Low	
B13	Spare	Input	Active Low	
B14	No Connection	—	—	—
B15	ECU Power Relay Control	Output	Active Low	
B16	No Connection	—	—	—
B17	Buffered Idle Validation Switch-1	Output	Active High	
B18	No Connection	—	—	—
B19	Output Supply # 3 (~Vbatt)	Output	Switch Power	
B20	Vehicle Speed Sensor (-)	Input	Analog	
B21	No Connection	—	—	—
B22	Analog Ground	ECU Sensor Ground		
B23	Analog Ground	ECU Sensor Ground		
B24	Retarder Stalk Switch?	Input	Analog Sensor	
B25	No Connection	—	—	—
B26	Output Supply # 2 (~5 V)	Output	Sensor Power	
B27	Brake Pressure Switch	Input	Analog/ Active Low	Analog Input used to read ground-connected normally. Open Brake Pressure Switch (Not Sensor)
B28	No Connection	—	—	—
B29	No Connection	—	—	—
B30	Spare	Input	Active High	

## VECU Connector C (Green)

Pin	Pin Name/Description	I/O	Type	Comment
C1	J1587/1708 Information Data Link (B) (SAE J1708 (A))		Bidirectional Data link	J1587/1708 Information Data Link (Slow Speed)
C2	J1587/1708 (A) (SAE J1708 (B))			
C3	No Connection	—	—	—
C4	J1939 Control Data Link/A (CAN_H)		Bidirectional Data link	J1939 Control Data Link (High Speed)
C5	J1939 Control Data Link/B (CAN_L)			

### Notes

---



---



---



---



---



---



---



---



---



---



---



---



---



---



---



---



---



---



---



---



---



---

# Data Link

The VNR Electric contains many Electronic Control Units (ECU) for operating many of the vehicle functions. Most ECUs are linked together using one or more data links for sharing information.

Some ECUs operate independently, but most rely on interaction with other ECUs to perform their functions.

All ECUs use some form of Input and Output devices to perform their functions. These devices may include switches, sensors, solenoids and relays. **Never** tie or splice into a sensor or input device used by an ECU. This could affect the proper operation of the sensor. Likewise, never tie into an output device, which is controlled by an ECU, unless authorized to do so elsewhere in this document.

## Data Link Communication

Communication between the different ECUs take place via the three data links, the SAE (Society of Automotive Engineers) J1939 data link, J1587/1708 data link and J2284 data link. Generally, networks with SAE J1939 have a communication speed of 250 kbit/s, SAE J1587/1708 of 9.6 kbit/s and SAE J2284 of 500 kbit/s. All data links and most subnets use CAN bus communication.

CAN is a message-based protocol with twisted-pair cabling between control units. All the units within a CAN can initiate communication but only one can send data at a given time.

## Data Link Flow

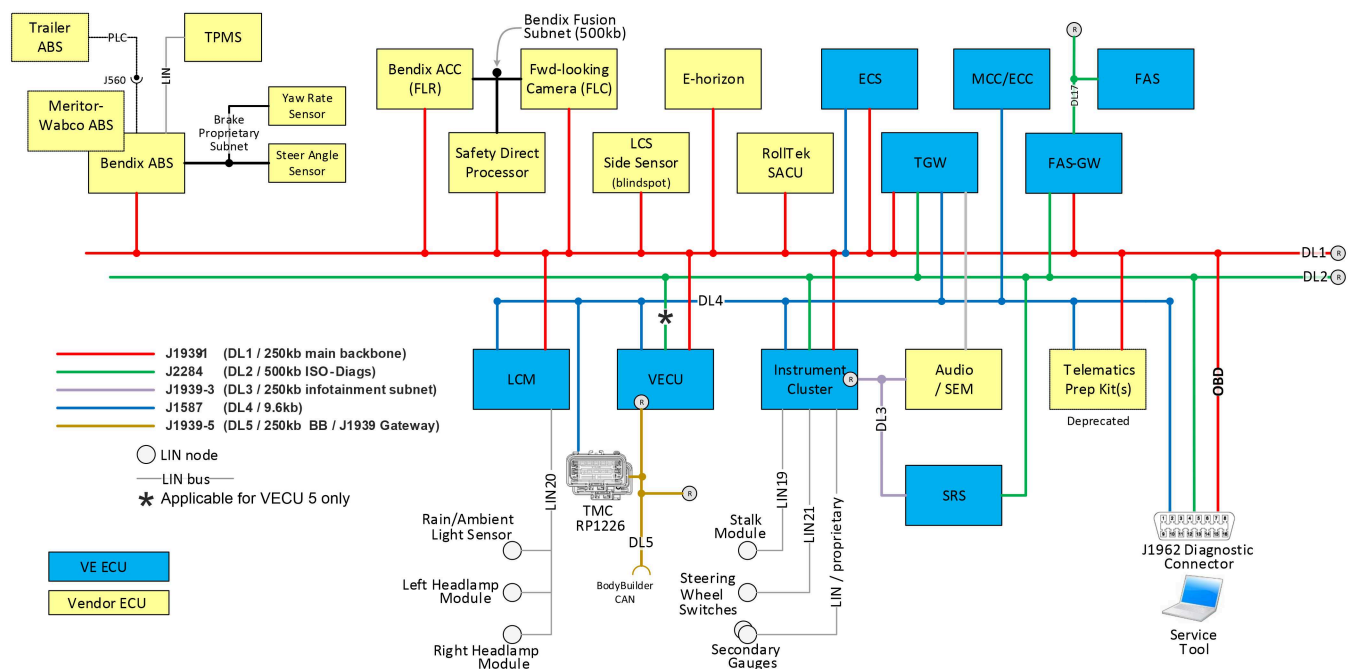

T3180437

Electronic Control Unit (ECU)	Description
ABS	Anti-lock Braking System
CAN	Control Area Network
ECC/MCC	Electronic Climate Control/ Manual Climate Control
ECS	Electronically Controlled Suspension
FAS	Front Active Steering
FAS-GW	Front Active Steering-Gateway

Electronic Control Unit (ECU)	Description
FLC	Forward Looking Camera
FLR	Forward Looking Radar
LCM	Light Control Module
LCS	Lane Change System
LIN	Local Interconnect Network
OBD	On-board Diagnostic
SACU	Side Airbag Control Unit (RollTek)
SDP	Safety Direct Processor
SEM	Services and Entertainment Module
SRS	Supplementary Restraint System
TGW	Telematics Gateway
TPMS	Tire Pressure Monitoring System
VECU	Vehicle Electronic Control Unit

**Notes**

---



---



---



---



---



---



---



---



---



---



---

# Electrical system Bridge plan

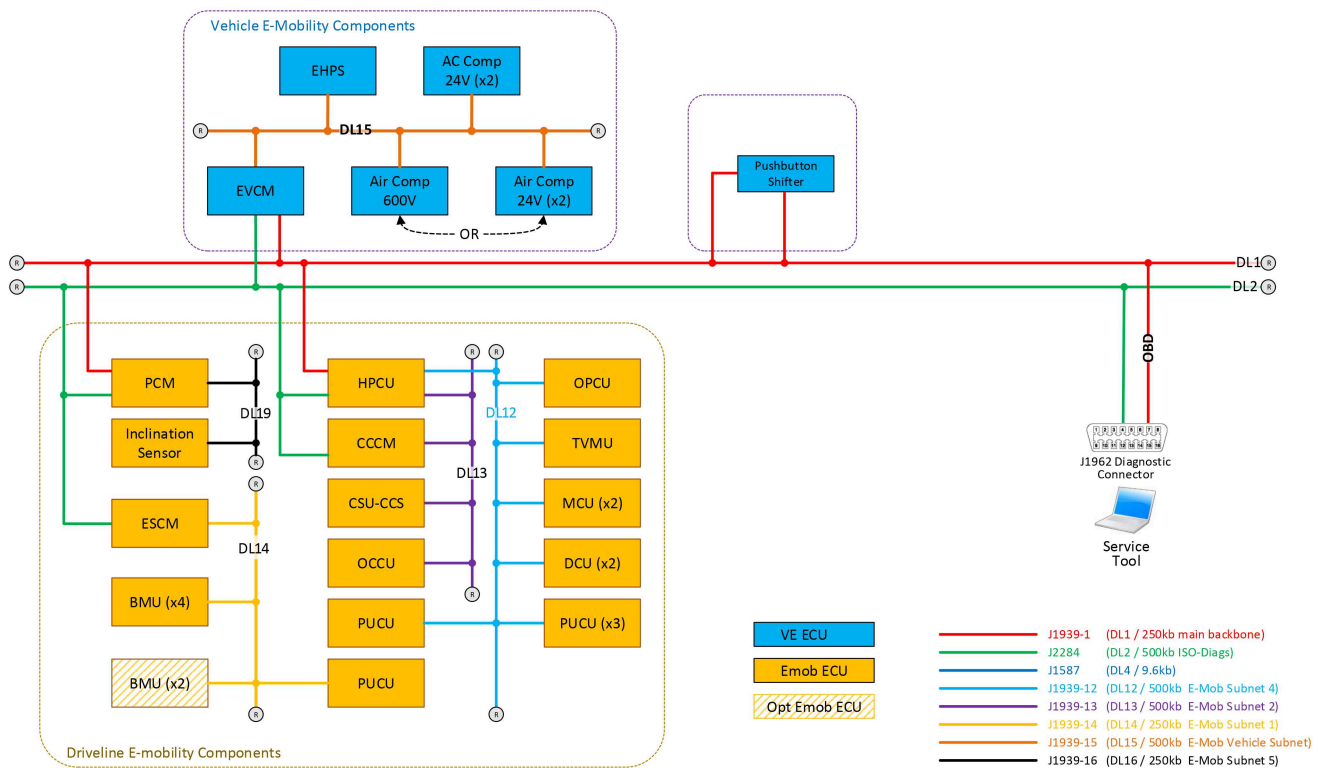

T3180436

Acronym	Description
AC	Air Condition
BB	Body Builder
BMU	Battery Monitoring Unit
CAN	Control Area Network
CCCM	Combined Charging system Control Module
CSU-CCS	Charging Switch Unit- Combined Charging system
DCU	Direct Current Unit
ECU	Electronic Control Unit
EHPS	Electro-Hydraulic Power Steering
ESCM	Energy Storage Control Module
EVCM	Electromobility Vehicle Control Module
HPCU	Hybrid Powertrain Control Unit
MCU	Motor Control Unit
PCM	Powertrain Control Module
PUCU	Pump Control Unit
OCCU	On-board Charger Control Unit (Not applicable)
OPCU	Oil Pump Control Unit
TVMU	Traction Voltage Monitoring Unit

# Electrical system Bridge plan+

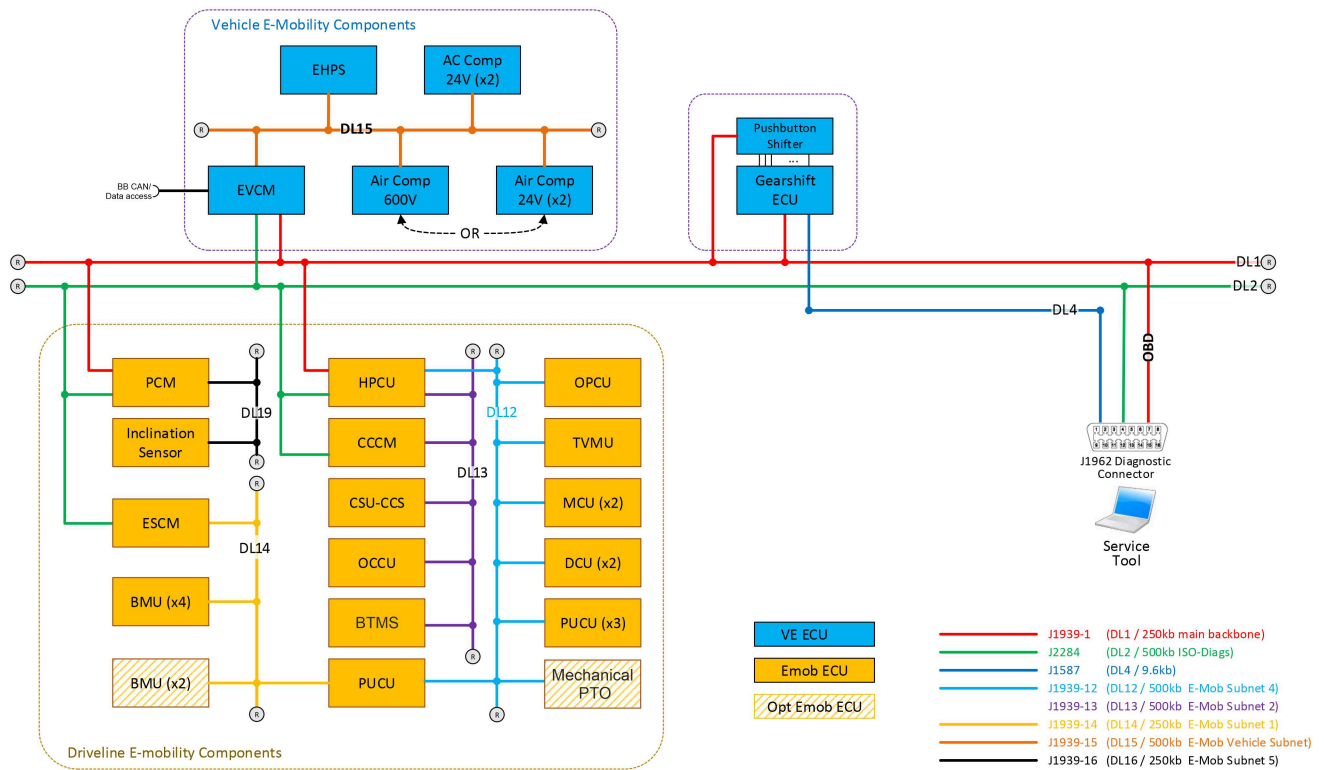

T3180392

Acronym	Description
AC	Air Condition
BB	Body Builder
BMU	Battery Monitoring Unit
CAN	Control Area Network
CCCM	Combined Charging system Control Module
CSU-CCS	Charging Switch Unit- Combined Charging system
DCU	Direct Current Unit
ECU	Electronic Control Unit
EHPS	Electro-Hydraulic Power Steering
ESCM	Energy Storage Control Module
EVCM	Electromobility Vehicle Control Module
HPCU	Hybrid Powertrain Control Unit
MCU	Motor Control Unit
PCM	Powertrain Control Module
PUCU	Pump Control Unit
OCCU	On-board Charger Control Unit (Not applicable)
OPCU	Oil Pump Control Unit
TVMU	Traction Voltage Monitoring Unit

## SAE J1939 Control Data Link

The system's **control signals** are sent via this link.

The J1939 link is fast, operating at 250 K bits per second (250 K Baud rate). This operating speed allows the system to function more effectively and adapt quickly to changing conditions and vehicle requirements.

The link complies with SAE standards and consists of two twisted wires, A yellow wire (CAN\_H), and a green wire (CAN\_L). The twisted wire set [0.89 twists per 25.4 mm (1 inch) or 33 twists per meter (3.28 feet)] is used to protect the link from electrical interference.



### CAUTION

No modifications or connections should be made to wires CAN\_H (yellow) or CAN\_L (green). These wires carry high-speed communications between the electronic systems in the vehicle. **Any modification, connection, or damage to these wires can result in the failure of the vehicle electronic systems.**

### *Terminating Resistor*

Terminating resistors are wired into each end of the J1939 (DL1) data link.

Only two terminating resistors are used in a data link. Never install three in a data link. If more than two terminating resistors exist in the J1939 circuit, damage to the ECU electronics can occur over time. You can easily check to see if you have two resistors by measuring the resistance between circuits CAN\_H and CAN\_L at the diagnostic connector, with the ignition Off. The correct resistance is 50 - 70  $\Omega$ .

The purpose of these resistors is to prevent data link signal reflections. They must remain connected for the system to function properly.

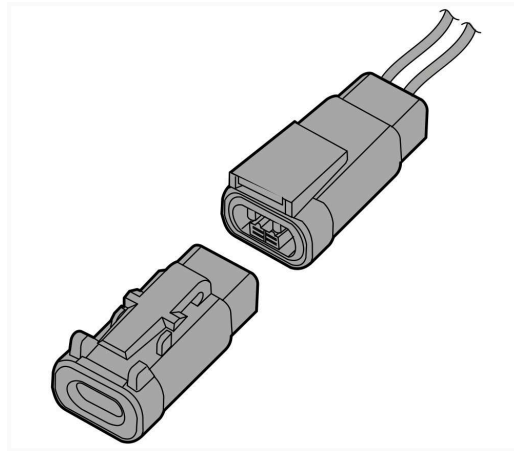

Fig. 1 J1939 Terminating Resistor

## SAE J2284 Control Data Link

The system **control signals** are sent via this link.

The J2284 link is very fast, operating at 500 K bits per second (500 K Baud rate). This operating speed allows the system to function more effectively and adapt quickly to changing conditions and vehicle requirements.

The link complies with SAE standards and consists of two twisted wires, A yellow wire (CAN\_H) and a green wire (CAN\_L). The twisted wire set [0.89 twists per 25.4 mm (1 inch) or 33 twists per meter (3.28 feet)] is used to protect the link from electrical interference.



### CAUTION

No modifications or connections should be made to wires CAN\_H (yellow) or CAN\_L (green). These wires carry the high-speed communications between the electronic systems in the vehicle. **Any modification, connection to, or damage to these wires can result in the failure of the vehicle's electronic systems.**

### *Terminating Resistor*

Terminating resistors are wired into each end of the J2284 (DL2) data link.

Only two terminating resistors are used in a data link. Never install three in a data link. If more than two terminating resistors exist in the J2284 circuit, damage to the ECU electronics can occur over time. You can easily check to see if you have two resistors by measuring the resistance between circuits CAN\_H and CAN\_L, at the diagnostic connector, with the ignition Off. The correct resistance is 50 - 70  $\Omega$ .

The purpose of these resistors is to prevent data link signal reflections. They must remain connected for the system to function properly.

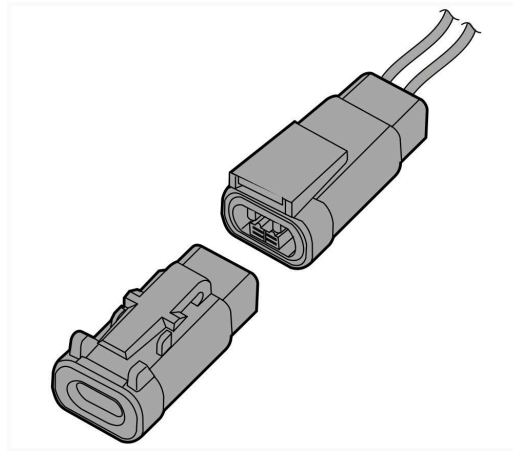

Fig. 2 J2284 Terminating Resistor



## Diagnostic Connector

The diagnostic connector is located in the driver side kick panel. The diagnostic connector is connected to the ISO information link and gives the system a way to communicate with an external PC or diagnostic tool.

With a PC or diagnostic tool connected, error codes can be read from all the control units. This is important in fault tracing to carry out basic checks of all the vital parts of the vehicle's electronics.

Some programming can also be done via the diagnostic connector.

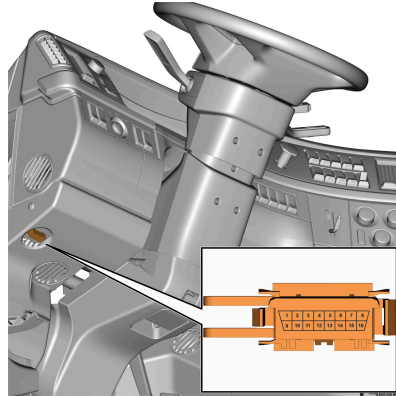

Fig. 3 Diagnostic Connector (16 Pin)

Pin Allocation for the 2013 SAE J1962 16-pin Vehicle Diagnostic Connector (Global Commonality)

### 16 Pin Diagnostic Connector (OBD 13) Definitions

16 Pin Diagnostic Connector (OBD 13 SAE J1962-Type A Connector)	
PIN	Definition
1	OEM discretionary (assigned as: Key switch – ignition signal for AM tool)
2	Bus positive line of SAE J1850 (Not Used)
3	OEM discretionary (assigned as: SAE J1939-15_CAN_H)
4	Chassis ground
5	Signal ground 6 CAN_H line of ISO
6	CAN_H line of ISO 15765-4
7	K line of ISO 9141-2 and ISO 14230-4 (Not Used)
8	OEM discretionary (Not assigned)
9	OEM discretionary (Not assigned)
10	Bus negative line of SAE J1850 (Not Used)
11	OEM discretionary (assigned as: SAE J1939-15_CAN_L)
12	OEM discretionary (assigned as: SAE J1708 / J1587 positive)
13	OEM discretionary (assigned as: SAE J1708 / J1587 negative)
14	CAN_L line of ISO 15765-4
15	L line of ISO 9141-2 and ISO 14230-4 (Not Used)
16	Battery positive voltage

## Body Builder Can Gateway

This function opens a CAN interface to the truck internal CAN connections and makes it possible to monitor the truck via the CAN bus, by sending/receiving J1939 standard messages.

Body builder equipment should comply with the standards defined for the following types of communication bus:

- SAE J1939-11 (twisted wires)
- SAE J1939 (physical layers)
- SAE J1939-71 (functional layers)

**Note:** The body builder CAN includes a 120-Ohm terminal resistor inside the VECU.

The external equipment installer is responsible for ensuring that the CAN connection has the correct terminal.

For more detailed information, refer to standard SAE J1939.

## Multiplexing Body Builder DL5 J1939 CAN

The multiplexing system BB J1939 CAN is used to provide control and communication between all major functional areas on a vehicle. The system offers simplified communication between the body builder module and other related electrical systems. Multiple signals are sent over a single pair of twisted wires, as opposed to individual wires for each function. The J1939 data link is used to send these signals.

The benefit of this arrangement is fewer wires, sensors and connections are required for communication purposes between systems. Also, there is greater signal consistency and reliability.

## Multiplexing Parameters

SAE	CAN Network	Source of Message	Receiver of Message	Update Rate	PGN Signal Names (SPN)
ACC1 (65135)	J1939-X	VECU (as ACB)	Ext CAN	100 ms	Forward vehicle speed Forward vehicle distance ACC Set Speed ACC Mode ACC set distance mode Road curvature ACC Target Detected ACC System Shutoff Warning ACC Distance Alert Signal
ACC Status (65296)	J1939-X	VECU (as ACB)	Ext CAN	100 ms	(Proprietary message from ACB) Audible Following Distance Alert Visual Following Distance Alert Vehicle Following Distance Vehicle Following Interval ACB tell-tale Indicator Status
PTOI (PGN 65264)	J1939-X	VECU	Ext CAN	100 ms	Power Takeoff Information
HOURS (PGN 65253)	J1939-X	VECU	Ext CAN	On Request	Engine Total Hours of Operation 247 Engine Total Revolutions 249
ACB Critical Events (PGN 65297)	J1939-X	VECU (as ACB)	Ext CAN	100 ms	CMT Intervention Impact Alert

SAE	CAN Network	Source of Message	Receiver of Message	Update Rate	PGN Signal Names (SPN)
AIR1 (PGN 65198)	J1939-X	VECU	Ext CAN	1 second	Pneumatic Supply Pressure 46
AMB (65269)	J1939-X	VECU (as EMS)	Ext CAN	1 second	Ambient Air Temperature, Barometric pressure
Brakes (PGN 65274)	J1939-X	VECU (as IC)	Ext CAN	1 second	Brake Application Pressure (SPN 116) Brake Primary Pressure (SPN 117) Brake Secondary Pressure (SPN 118) Parking Brake Red Warning Signal (SPN 3557)
CCVS (65265)	J1939-X	VECU	Ext CAN	100 ms	Vehicle speed, etc.
CVW (PGN 65136)	J1939-X	VECU (per reply)	Ext CAN	On Request	Weights
DD (65276)	J1939-X	VECU (as IC)	Ext CAN	1 second	Washer Fluid Level (SPN 80)
DM1 (PGN 65226)	J1939-X	VECU (as received)	Ext CAN	1 second	Fault lamps, etc.
EBC1 (PGN 61441)	J1939-X	VECU (as ABS)	Ext CAN	100 ms	Anti-Lock Braking (ABS) Active, etc.
EBC1 (PGN 61444)	J1939-X	VECU	Cummins	100 ms	Remote Accelerator Pedal Enable Switch (SPN 969), Accelerator Interlock Switch (SPN 972)
EBC2 (WSI PGN 65215)	J1939-X	VECU (as ABS)	Ext CAN	100 ms	Wheel speeds
EBC5 (PGN 64964)	J1939-X	VECU (as ABS)	Ext CAN	100 ms	Hill Holder Mode
EEC2 (61443)	J1939-X	VECU	Ext CAN	50 ms	Accelerator Pedal Position
ETC1 (PGN 61442)	J1939-X	VECU (as TECU)	Ext CAN	10 ms	Driveline engaged status
ETC2 (PGN 61445)	J1939-X	VECU (as TECU)	Ext CAN	100 ms	Current gear status, requested gear status
HRW (PGN 65134)	J1939-X	VECU (as ABS)	Ext CAN	20 ms	Wheel speeds
Request	J1939-X	Ext CAN	VECU		PGN
Request	J1939-1	VECU	As received	As received in most cases	PGN

SAE	CAN Network	Source of Message	Receiver of Message	Update Rate	PGN Signal Names (SPN)
SERV (PGN 65216)	J1939-X	VECU	Ext CAN	On request	Service component identification Service distance (associated to upper Service component ID) Service component identification Service delay/calendar time based (associated to upper Service component ID) Service component identification Service delay/operational time based (associated to upper Service component ID)
SOFT (PGN 65242)	J1939-1	VECU	Ext CAN	On request	Variable length
TCFG (PGN 65250)	J1939-1	VECU	Ext CAN	On request	Number of Reverse Gear Ratios 958 Number of Forward Gear Ratios 957 Transmission Gear Ratio 581
TD (PGN 65254)	J1939-X	VECU (as IC)	Ext CAN	On Request	Time & date
VD (PGN 65248)	J1939-X	VECU (as IC)	Ext CAN	1 second	Total Vehicle Distance 245 Convert from VDHR
VDHR (PGN 65217)	J1939-X	VECU (as IC)	Ext CAN	1 second	High-Resolution Total Vehicle Distance 917
VH (PGN 65255)	J1939-X	VECU	Ext CAN	On request	Total Vehicle Hours 246 Total power take-off Hours 248
VI (PGN 65260)	J1939-X	VECU (as EMS)	Ext CAN	On request	VIN
VW (PGN 65258)	J1939-X	VECU (as ECS)	Ext CAN	1 second	Weights (note this is multiframe so is difficult to respond to so will gateway at received rate)
VEP1 (PGN 65271)	J1939-X	VECU (as IC)	Ext CAN	1 second	SPN 168 Battery Potential/Power Input 1

**Note:** Although the VECU sends output messages, the source address is set as the ECU originating the information.

**Note:** Messages that rates “on request” are requested by the J1939 request PGN 59904 described in J1939-21. For example, requesting engine hours is done by sending EAFF or EA00 with data E5 FE 00 (hex values).

**Note:** Not all messages are supported on all vehicle. For example, GFC is not available, even for natural gasoline engines. However, GFC support could be available for these engines in the future.

## Commands Accepted on the DL5 Body Builder Connector J1939

Message	Update Rate	Content
EBC1 (PGN 61441)	100 ms	Remote Accelerator Pedal Enable Switch Accelerator Interlock Switch
EEC2 (61443)	50 ms	Accelerator Pedal Position 2 Remote Accelerator Pedal Position





**V O L V O**

**Volvo Trucks North America**

<http://www.volvotrucks.com>